

PHYSICAL SCIENCES

ENGLISH MEDIUM

CLASS VIII



Published by the Government of Telangana, Hyderabad.

Respect the Law
Get the Rights

Grow by Education
Behave Humbly



© Government of Telangana, Hyderabad.

First Published 2013
New Impressions 2014, 2015, 2016, 2017, 2018, 2019, 2020
2021, 2022, 2023

All rights reserved.

No part of this publication may be reproduced, stored in a retrieval system, or transmitted, in any form or by any means without the prior permission in writing of the publisher, nor be otherwise circulated in any form of binding or cover other than that in which it is published and without a similar condition including this condition being imposed on the subsequent purchaser.

The copy right holder of this book is the Director of School Education, Hyderabad, Telangana.
We have used some photographs which are under creative common licence. They are acknowledge at the end of the book.

This Book has been printed on 90 G.S.M. Maplitho,
Title Page 250 G.S.M. White Art Card

Government's Gift for students' progress 2023-24

Printed in India
at the Telangana Govt. Text Book Press,
Mint Compound, Hyderabad,
Telangana.

Foreword

The nature is life source for all living organisms. Though it usually appears simple and normal, the intricacies of the very nature often challenges us to untie the tough knots of its hidden secrets, day in and day out. That is why, Galileo Galilei, the Italian astronomer, emphasized that scientific learning is nothing but improving the ability of questioning. The classroom teaching of science must be in such a way that it encourages children to think and work scientifically.

This textbook designed to help students achieve Science Education objectives such as scientific perspective, scientific attitude, the ability to develop scientific process skills, the using principles, theories, rules and functional relationships. Based on the recommendations of National Curriculum Framework - 2005, Right to Education Act - 2009, and Curriculum Framework Document - 2011, the curriculum provides students with experiential learning to enhance their learning.

Textbooks are designed to achieve the desired learning outcomes. Teachers should devise suitable teaching strategies to enhance the expected learning outcomes in children by the end of the class. A move away from rote learning approaches is necessary for the effective implementation of continuous comprehensive assessment. Teachers need to be aware of the methods needed to evaluate children's progress through formative and summative methods. It is very useful for teachers and students that textbooks not provide content but also reflect teaching methods and assessment methods.

We thank the Vidya Bhawan Society, Rajasthan, Dr. Desh Panday Rtd Prof. College of Engineering Osmania University and Sri D.R. Varaprasad former Lecturer ELTC Hyderabad for their cooperation in developing these new text books. Our special thanks to Faculty of School of Education Tata Institute of Social Sciences (TISS), Hyderabad and Sri Ramesh Khade, Communication Officer, CETE, TISS-Mumbai and Designers identified by SCERT for their technical support in redesigning of the textbooks. The writers for preparing the lessons, the editors for checking the textual matters and the DTP group for cutely composing the text book.

Place : Hyderabad

Date : 07 December

Director,
SCERT, Hyderabad

NATIONAL ANTHEM

- Rabindranath Tagore



Jana-gana-mana-adhinayaka, jaya he
Bharata-bhagya-vidhata.
Punjab-Sindh-Gujarat-Maratha
Dravida-Utkala-Banga
Vindhya-Himachala-Yamuna-Ganga
Uchchhala-jaladhi-taranga.
Tava shubha name jage,
Tava shubha asisa mage,
Gahe tava jaya gatha,
Jana-gana-mangala-dayaka jaya he
Bharata-bhagya-vidhata.
Jaya he! jaya he! jaya he!
Jaya jaya jaya, jaya he!!

PLEDGE

- Pydimarri Venkata Subba Rao

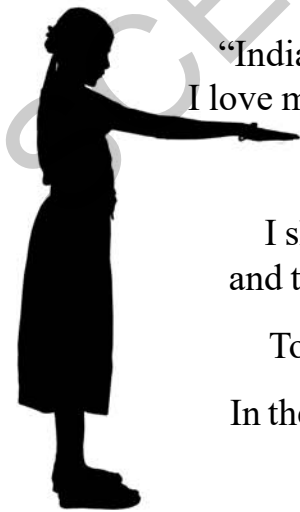

“India is my country; all Indians are my brothers and sisters.
I love my country, and I am proud of its rich and varied heritage.

I shall always strive to be worthy of it.

I shall give my parents, teachers and all elders respect,
and treat everyone with courtesy. I shall be kind to animals.

To my country and my people, I pledge my devotion.

In their well-being and prosperity alone lies my happiness.”

INDEX

<i>Name of the lesson</i>	<i>Periods</i>	<i>Month</i>	<i>Page No.</i>
1 <i>Force</i>	8	June	1
2 <i>Friction</i>	8	July	20
3 <i>Synthetic fibres and plastics</i>	11	July	34
4 <i>Metals and non-metals</i>	12	August	54
5 <i>Sound</i>	12	August	68
6 <i>Reflection of light by plane surfaces</i>	6	September	87
7 <i>Coal and petroleum</i>	12	October	97
8 <i>Combustion, fuels and flame</i>	10	November	112
9 <i>Electrical conductivity of liquids</i>	11	November	125
10 <i>Some natural phenomena</i>	11	December	138
11 <i>Stars and solar system</i>	13	January	154
12 <i>Graphs of motion</i>	4	February	178
<i>Revision</i>		March	



THE CONSTITUTION OF INDIA

Preamble

WE, THE PEOPLE OF INDIA, having solemnly resolved to constitute India into a **SOVEREIGN SOCIALIST SECULAR DEMOCRATIC REPUBLIC** and to secure to all its citizens:

JUSTICE, social, economic and political;

LIBERTY of thought, expression, belief, faith and worship;

EQUALITY of status and of opportunity; and to promote among them all

FRATERNITY assuring the dignity of the individual and the unity and integrity of the Nation;

IN OUR CONSTITUENT ASSEMBLY this twenty-sixth day of November, 1949 do **HEREBY ADOPT, ENACT AND GIVE TO OURSELVES THIS CONSTITUTION.**



We can observe many changes around us. For example changes in seasons, change during sun rise and sun set, changes in tides of sea etc. Have you ever thought about the cause behind these changes? In ancient days, people thought that an invisible force was responsible for the changes occurring in nature. Even now many people believe that an invisible force exists that causes whatever is happening in the world.

Later, the concept of force was developed, but it was limited to explaining our efforts and actions. The words force, effort, strength and power had almost the same meaning at that time. Have you ever wondered what forces are? What are the different types of forces and how do they act? Let's find out the answers to such questions in this chapter.

For instance, when you ride a bicycle, most of the time your legs are pushing down on the pedals. To push you have to make an effort. When you pick up your school bag you have to make an effort in order to lift or pull the bag upwards and off the ground. When you open a door you make an effort on the door knob with your hands either to push the door forward or pull it backward.

1.1 What is force?





Have you ever picked a heavy stone? How does a paper boy throw a newspaper? Have you ever wondered about this action? Actions like stretching a rubber band, pulling a rickshaw, rowing a boat etc., are some more examples where our efforts help to change the position or shape of the object. Such actions like picking, squeezing, twisting, stretching, lowering and lifting etc., cause a change in the state of an object. Now let us try to group these tasks as a pull or a push.

Activity-1

Identifying push or pull

Table-1 gives some examples involving the actions like digging, sucking, erasing, falling, attracting, raising etc. Classify these actions in terms of a push or a pull or both. Write pull or push in the blank boxes. If you feel that the action involves both push and pull, write "both" in the box.

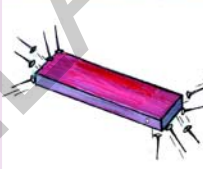
Table 1: Identify tasks as Push or Pull or Both

S.No.	Action	Diagram	Push/Pull/Both
1	Digging bore well		
2	Sipping Juice with a straw		
3	Erasing letters on blackboard with duster		
4	A magnet attracting nails		
5	Fruits falling from tree		
6	Hoisting a flag		

- List three more activities where we exert force which appears as a push.
- List three more activities where we exert a force as a pull.
- State three actions which involve both push and pull.

Based on this activity, can you explain what is a force?

Shall we call the effort done on an object by means of pushing or pulling as a force exerted on the object?

We cannot directly see the forces acting on a body, but we can see the effects caused due to the forces.

When an object slips off your hand, why does it always fall down? If you roll a ball on a level ground, it slows down and after sometime it will come to a stop. What makes the ball stop? What forces acting on objects, change their state or position of motion?

1.2 Types of forces

Contact forces and forces at a distance (Field Forces)



Observe the following figures.



Fig-1 (a)
Pressing tube to come out of the toothpaste.



Fig-1(b)
Change in direction of the needle of the compass due to bar magnet.

Why does the toothpaste come out when we press the tube? Why does the needle of a magnetic compass move when we place a bar magnet near it? Have you observed the difference between the force you applied on the tube and the force applied by a magnet on the needle of a compass?

In Fig.1 (a) you observe that there is direct physical contact (or interaction) between your hand and the tube. Force, which results when there is a direct physical contact between two interacting objects, is known as **contact force**.

In Fig.1 (b) the needle of the compass changes its direction without any physical contact with the bar magnet. But a force must be acting on the needle. The force which occurs without any physical contact between two objects is known as a **force at a distance** or **field force**.

1.3 Forces acting at a distance (field forces)

1.3.1 Magnetic force

You must have done some experiments with magnets in class VI. Let us recall some of your experiences.

Activity-2

Observing the magnetic force.

Take a sewing needle. Rub it with a bar magnet several times always moving the magnet in the same direction. Does the needle get magnetised? You may find that the needle acts like a magnet. With the help of a magnetic compass you can identify the north and south poles of the needle. Pin a red coloured cork ball to South Pole and white ball to North Pole of the needle; then drop it in a bowl of water, it floats. (Fig-2)

Make another needle in the same way. Float both the needles such that same colour balls face each other (either red or white balls).

- What happens to the needles? How do they move?

Similarly, float both the needles in such a way that different colour balls face each other.

- What happens this time?

How do the needles attract each other?
How do they repel?



Fig-2: Making needle magnets and floating them in a bowl of water.

You have learnt in class VI that like poles of two magnets repel each other and unlike poles attract each other. You can observe the red end of one needle and white end of another needle attract each other, and ends with same colour repel.

Now, you know that like poles repel or push each other away and unlike poles attract or pull each other. This action of pull or push arises due to a **magnetic force**. A magnet can attract or repel another magnet without contact. So magnetic force is a field force.

1.3.2 Electrostatic force

Activity-3

Observing electrostatic forces

Take a balloon. Inflate it and tie up the open end. Now cut a paper into small pieces and place them on the floor. Rub the balloon with a paper and bring the balloon near the pieces of papers. What happens now? Are the bits of paper pulled towards the

balloon? (Fig-3) Why does the balloon pull or attract the pieces of paper? Try to use pepper and salt in the place of pieces of paper. What do you observe?



Fig-3: Charged balloon attracting bits of paper

We can say that when the balloon is rubbed with a paper, it acquires an electrostatic charge on its surface. The balloon is now said to be a charged body. When it is brought near the bits of paper, the pieces acquire opposite charge and will rise and cling to the balloon.

The force exerted by a charged body on another charged body is known as **electrostatic force**.

This force comes into play even when the bodies are not in contact. It is an example of a force at a distance.

1.3.3 Gravitational force

It is our common experience that if a pen slips off from our hands it falls down to the floor.

- Why does the pen fall down?
- What is the force which pulls the pen down?

If we keep the same pen on a table, it does not fall down. Why?

Generally our answer would be that the table supports the pen. If the table does not support the pen it would fall down until it is supported by another object, like the floor.

- Why does a stone thrown up into the sky fall back to the earth?
- Why do rivers flow down to the sea?
- How does the earth hold the atmosphere?
- Is there any force pulling the objects towards earth?

If an object is thrown upwards, there exists a force which pulls it down towards the earth, because of this it falls down to the ground. We call this force as a **gravitational force**.

Every object on the Earth or close to Earth, will experience a gravitational pull. The force of gravity is not just due to the attraction of the Earth. It is a force of attraction that exists between any two bodies (or masses) everywhere in the universe.

As the earth is so massive and huge, all the other objects close to the earth are attracted or pulled towards it. When you sit in your class room, there will be a gravitational force between you and your teacher, and a similar force exists between you and the black board.

You cannot experience the gravitational force that exists between you and your teacher or between you and the black board because it is very small when compared to the gravitational force exerted by the earth on these objects. You will learn more about this in the lesson "Gravitation" in higher classes.

Gravitational force works even the objects are not in contact. So, this is an example of field force.



Think and discuss

A cricket ball of mass 'm' is thrown upward with some initial speed. If the air resistance is neglected, what forces are acting on the ball when it reaches

- (a) half its maximum height and
- (b) its maximum height?

1.3.4 Explaining of force acting at a distance: concept of field

The force which acts between two bodies, when the bodies are not directly touching each other is called force at a distance. We can explain the forces at a distance by using the concept of field.

Activity-4

Visualizing magnetic field.



Fig-4 : Magnetic field

- Take a bar magnet and place it on a table. Place a thick white paper over it (White drawing sheet).
- On the paper, sprinkle fine powder of iron (iron filings) as shown in the fig -4.
- Tap the table or the paper gently with pen/pencil.

- What do you observe? Do you find any pattern of iron filings there?
- Rotate the magnet in different directions and do the same. How has the pattern changed?

You can see that in a small space around the magnet, iron filings set themselves in a pattern because they are affected by the magnetic force of the field created by the bar magnet. The pattern represents the magnetic field. The space around the magnet where its influence can be detected is called the magnetic field. This field is three dimensional.

Thus, a field is a region in which a force can be experienced by another magnetic object placed at any point in that region.

A body creates a field and another body experiences the force by the field when it is placed in that field.

A magnetic field surrounds a magnet, an electric field surrounds electric charges and a gravitational field surrounds masses.

The strength of a field in a particular region can be represented by field lines; the greater the density of lines, the stronger the forces in that part of the field.



Think and discuss

Two identical bars, one which is steel and the other a magnet, are painted with the same colour. How can you tell which one is the magnet using only these two bars? (don't break the bars)

1.4 Contact Forces

1.4.1 Muscular Force



Fig-5

In all the actions that we perform in our daily life like brushing, bathing, eating, writing, driving and walking; we have to exert a force. Do you know from where the force comes? The force which we exert by using our body muscles is known as **muscular force**. Even when we smile our muscles exert force to bring changes in our face. Human beings and animals use muscular force to carry out their regular physical activities. Muscular forces can be exerted only through contact.

Activity-5

Preparing a list of examples for muscular force

List at least ten activities where we apply muscular force to perform various tasks, in table - 2.

Table-2

Sl.No	List of activities where we exert force
1	Lowering a basket
2	
3	
4	
5	
6	

Usually we are unaware of the muscular forces that are responsible for the various actions taking place inside our body, like blood circulation, expansion and contraction of lungs during breathing, heart beat etc.

- Do you feel your muscles get tightened while performing any physical activity? What could be the reason for it?

Activity-6

Observing the changes in any muscle while working

Take a dumbbell and lift it in different ways. Observe while doing this exercise which muscle is going to be shortened.

Ask your friends to do the same and observe the movement of their muscles.

The term muscle refers to multiple bundles of muscle cells held together. Muscles are normally arranged in such a way that as one group of muscles contract or shortens, another group relaxes or expands. For example,

when you are throwing a ball, the muscles in the front of the chest and shoulder expand and pull our hand forward, while the muscles in the back of the shoulder contract and control the movement of our hand.

1.4.2 Force of Friction

When you roll a ball on a level ground it invariably stops after sometime.

- Why does the ball stop?
- Is there any hidden force which brings it to stop?

If you stop peddling your bicycle on a level road you observe that its speed decreases gradually.

- Why does the speed of the bicycle decrease gradually?
- Is there any force acting on it which tends to reduce its speed?

Does the change in speed of the ball and bicycle depend on roughness and smoothness of the surface on which they move? Let us find out.

Activity-7

Observing the motion of a ball on different surfaces

Try to roll a ball on different surfaces like carpet, rough roads, smooth floor etc. See that surfaces are plane, exerted force is same.

- On which surface does the ball roll farther?

The motion of the ball is different in each case. The force of resistance to the motion seems to be more on the rough surface than on the smooth surface. The rolling ball moves farther on a smooth marble floor than on a rough sandy surface.

Activity-8

Observing the motion of objects on an inclined plane

Take a tray. Place a small ice cube, eraser and a rupee coin on a line at one end of the tray. Now slowly lift this end of the tray as shown in the figure-6.

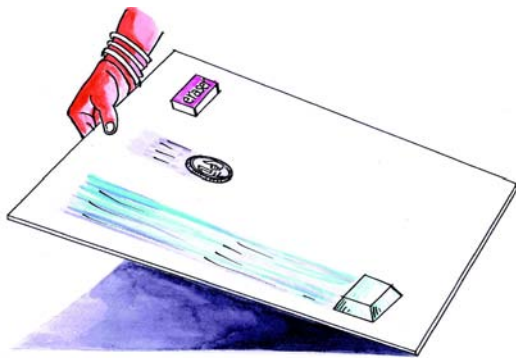

Fig-6: Motion of objects on an inclined plane.

- What do you observe?
- Which one of these three objects slides down first? Why?
- Do all the objects experience the same resistance to motion? If not why?
- Which one of the objects experiences more resistance to motion? Why?
- Why there is a change in resistance experienced by the objects though they all slide down on the same plane?

Do this activity with different objects like a book, a ball, a pen, a stone etc., and record your observations.

Friction is the resistance to the movement of a body over the surface of another body.



Fig-7

Did you ever experience slipping on a floor? What conditions caused you to slip? Did you experience slipping while you are walking on wet mud? Why do most road accidents happen during rainy days?

- Would it be possible to drive a car if there was no friction between the tyres and the road?

The direction of friction is always opposite to the direction of motion relative to the surface. Let's imagine a world without friction. Without friction, would it be possible to write with a pen on a paper or with a piece of chalk on the black board? Can we at least walk on a road without friction? You will learn more about friction in the next chapter.



Think and discuss

A book placed on a table is at rest. Is the force of friction acting on it or not? Explain.

1.4.3 Normal force

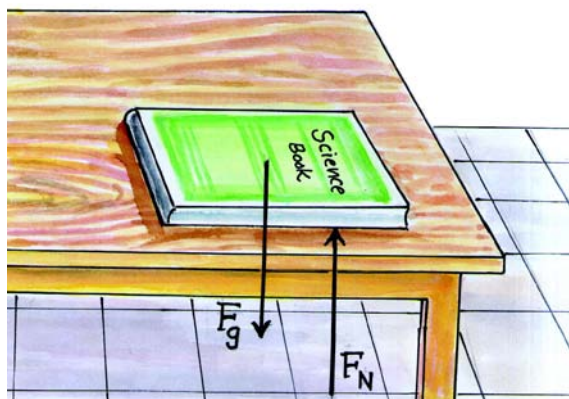

Fig-8: Force of gravitation and normal force acting on the book.

Place your science book on the table. Is it in a state of rest? Is there any force acting on that book? Imagine that the table has disappeared suddenly by magic. What will happen then? The book will fall down due to the gravitational pull of the Earth. Even when a book is lying on the table, the gravity pulls the book down all the time but it does not fall down because it is supported by the table. Therefore, there exists a force which supports the book against gravity by pushing it upward.

- What do we call this force?

Look at the fig.8 A direction which is perpendicular to the plane of a surface is said to be **normal**. The force that a solid surface exerts on any object in the normal direction is called the **normal force**.

In the above example the downward gravitational force is balanced by the upward normal force. Since these two

forces are of equal magnitude and acting in opposite directions, we say that the net force acting on the book is zero and the book is in equilibrium.

1.4.4 Tension

As shown in the figure-9 a wooden block is suspended with the help of a string and its free end is tied to the ceiling

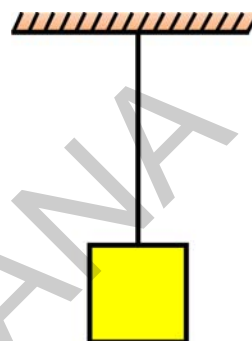

Fig-9

- What is the state of the wooden block?
- What forces are acting on it?
- What will happen if the string is broken?

We know that the wooden block would fall down due to gravitational pull (weight) of the earth if the string is broken.

For a wooden block tied to the string, gravity pulls down the wooden block all the time but it does not fall down because it is supported by the string. Thus, there exists a force which supports the wooden block against gravity by pulling it upward.

- What do we call this force?

When you try to stretch a rope or a string the tightness of rope or string is called **tension**. Tension is a contact force.

In the above example, as shown in fig-10, the upward tension force in the string is equal

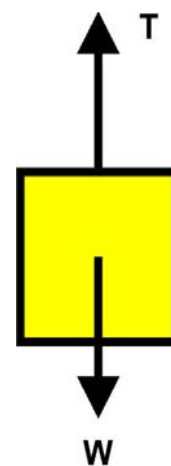

Fig-10

to downward gravitational force but in opposite direction. Hence, the two forces balance each other.

Lab Activity

Aim: To find the limiting force that can be borne by a string.

Material used: Spring balance, weights, light strings are of 10 cm length and of equal thickness, weight hanger.

Procedure:

1. Arrange the system as shown in figure-11. Put some small weights like 50 gm on the weight hanger and note the readings of the spring balance. Now, add some more weights to the hanger and note the readings of spring balance.



Fig-11

Do the same till the string is broken. Note the reading of the balance in the following table when the string is broken.

Find out the limiting force of different types of strings and mention the values in the given table.

Sl.No.	Type of String	Limiting Force

2. Separate the whole system from the ceiling, and tie the string to weight hanger and now slowly pull up the whole system with your hand when there is a small weight on the hanger.

While pulling up, note the readings of spring balance. Similarly, while slowly moving down, note the readings of spring balance.

- What do you observe from the readings when it is pulled up and released to move down?
- Is the string broken when the whole system is pulled quickly up?

 **Think and discuss**

- A system of two bodies A and B are placed as shown in figure. How many forces are acting on A and B respectively?
- Why is it necessary to separate contact force into a normal force and frictional force? Give at least two reasons.

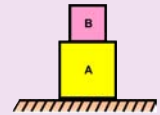

1.5 Net force

In reality, many forces can act simultaneously on a body. For example, there exists two forces on an object at rest placed on a horizontal floor. One is gravitational force (vertically down) and other is normal force (vertically up).

Do you observe any change in the state of rest of that object because of these forces? Obviously your answer is 'No'.

In this case two forces acting on the object are equal and opposite in direction. Hence, the object remains in the state of rest.

Technically, we say that the net force on this object is zero.

Imagine that the same object is kept in a lift which is accelerating.

- How many forces are acting on this object?
- Is the net force acting on the object zero? Why?

Note: When an object is in non uniform motion, it is said to be in acceleration.

The net force acting on an object kept in a lift which is accelerating is not zero, as the object is in non-uniform motion.

When two forces act on a body, as in the above case, one of the forces should be greater than the other to set the body in motion.

The strength of a force is usually represented by its magnitude. The direction of a force is as important as its magnitude. We represent the direction of force, magnitude using 'arrows' (\rightarrow).

Activity-9

Effects of net force acting on a table

- Try to push a heavy wooden table. (Fig-12a). Is it hard to push?



Fig - 12(a)

- Ask your friend to help you in pushing the table in the same direction, as shown in the fig.12 (b). Do you find it easier to move the table now? Why?



Fig - 12 (b)

You may notice that it is easier to push the table when you take the help of your friend. The force applied by your friend added to the force exerted by you, results in both forces being applied on the table in the same direction. The total force applied by both of you made it easy to move the table.

Now ask your friend to push the table from the opposite side as shown in fig.12(c). Does it move? If it moves, then in which direction does it move?

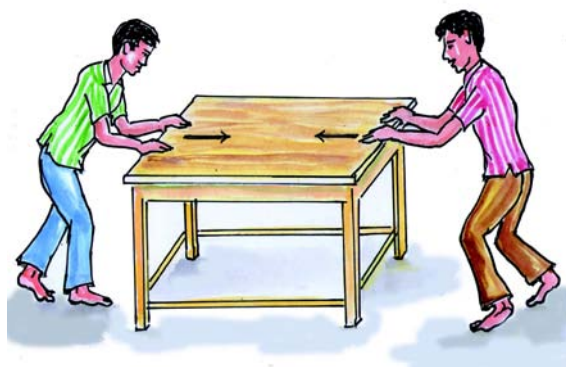

Fig-12(c)

When you and your friend push the table from opposite sides, the table doesn't move if both of you apply force with equal

magnitude. Let us assume that one of you exerts a larger force, what will happen? Why?

All forces have both magnitude and direction. While adding forces, the directions of forces have to be taken into account. When forces act on a body along a straight line and they are in the same direction the net force is taken as the sum of all forces acting on the body. To add forces, sign convention must be used.

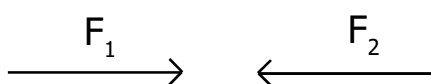

Fig - 13

As shown in the above figure the force F_1 directed towards right could be taken as positive and the force F_2 acting towards left could be taken as negative. Let the forces F_1 and F_2 act on the table in opposite directions as shown in the figure and $F_1 > F_2$,

$$\text{Then } F_{\text{net}} = F_1 + (-F_2) = F_1 - F_2$$

When the forces on a body in a straight line are in opposite directions, the net force is equal to difference between the two forces. The object at rest moves in the direction of the net force acting on it.

Activity-10

Effects of stretched rubber bands on fingers

Take a rubber band, stretch it using your fingers. When you stretch the rubber band it exerts force on your fingers and you feel

the force of pull on your fingers. What happens if you add one more similar rubber band around your fingers and stretch both together to the same length? Do you feel the combination of two bands exerts a larger force than that of one? Increase the number of rubber bands around your fingers and observe the force exerted on your fingers by the rubber bands.

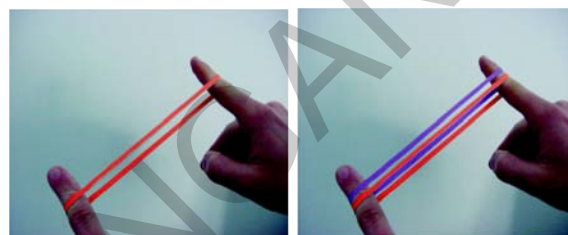

Fig-14 Stretching rubber bands

Let us say the force exerted by one rubber band is F units and the force exerted by the second rubber band is also F units. Then what will be the net force of two rubber bands? We can express it as:

$$F_{\text{net}} = F + F = 2F \text{ units}$$

The unit of force in SI system is newton(N).

What is the net force acting on your finger when three, four etc. rubber bands are used?

1.6 How to calculate net force from free body diagrams

The diagram showing all the forces acting on an object at a particular instant is called Free Body Diagram. It is denoted as FBD.

Example:

Let a car be moving with a non uniform speed along a road. What are the forces acting on the car? What is the net force acting along the vertical direction? What is the net force acting on the car along horizontal direction?

Draw all the relevant forces acting on the car. We call it a free body diagram (FBD).

Choose a coordinate system with X-axis and Y-axis as shown in figure-15. Add forces algebraically with sign conventions along X and Y axes separately. Then those values give net forces along X and Y directions respectively.

Solution:

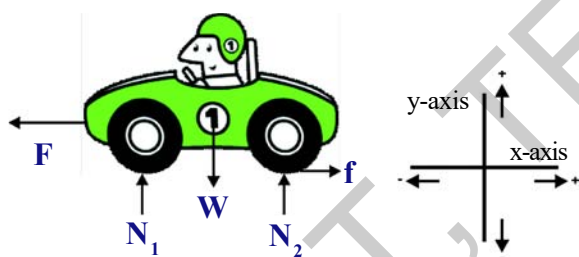

Fig-15: Free Body Diagram(FBD)

The forces acting on the car are shown in the fig-15. They are:

Force applied by the engine = F

Friction applied by road = f

Normal forces = N_1 and N_2

Gravitational force (F_g) = W

Net force along X-axis:

$$F_{\text{net, x}} = f - F$$

Net force along y-axis:

$$F_{\text{net, y}} = N_1 + N_2 - W$$



Think and discuss

- Play arm wrestling with your friend. Explain the winning of the game by using the concept of net force. Name forces acting on arm and their direction while playing the game. Try to draw FBD for this situation.

1.7 What Forces can do?

Activity-11

Effect of force on state of motion of an object and its direction.

Place a football on the ground. The ball will remain in a state of rest unless someone kicks the ball. Now kick the ball (Fig-16a). What happens? Does the ball start moving? Kick the moving ball again in the same direction (Fig-16b). What will be the result? Place your hand or leg against the ball. Does the ball stop? Or does it change its direction? Note your observations.

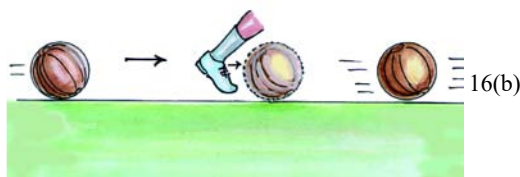

Fig-16: (a) Force applied on a ball at rest.

Fig-16: (b) Force applied on a moving ball in the direction of motion.

We can move the ball from its position of rest by applying a force on it. We can stop the moving ball and bring it back to rest by catching it. Give few more examples where the state of motion of an object changes due to the application of force.

You might have seen children playing with a rubber tyre by pushing it with a stick. They push the tyre again and again with the stick to increase its speed. Do you understand why the speed of the tyre increases whenever it is pushed by the stick?

With every push they are applying a little more force on the moving tyre in the direction of motion. Hence the speed of the tyre increases continuously.

If the net force acts in the direction of motion, the speed of an object moving with constant speed also increases. If the net force acts in a direction opposite to the motion, then it either slows down the object or brings it to a rest or it may change the direction of motion.

Give some more examples where the object speeds up or slows down or a change may occur in its direction of motion when we exert a force on it.

Activity-12

Effect of net force on direction of moving object

Hit a carrom coin with the striker. Ask your friends to do the same. Does the coin move in the same direction in each case? If not, why?

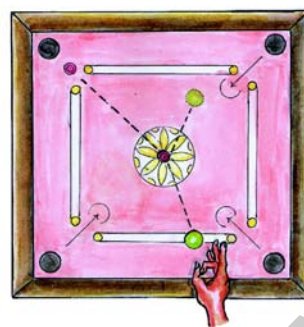

Fig.17

You can observe that in each case the direction of the coin changes.

When you hit the coin with the striker, not only does the coin change its direction, but the striker changes its direction too. What might be the cause for that?

From these observations, we can say that a net force stops a moving object or makes a stationary object move and also changes the speed and direction of a moving object.

Does the force change only the state of motion? Are there any other effects of force?

1.8 Other effects of force

Activity-13

Effects of force on the shape of an object



In table-3 some situations are given in the first column showing how the force is applied on an object. Observe the shape of the objects carefully before and after applying the force. In the above situations, observe if there is permanent or temporary change in shape of the object and fill the table.

Mark 'T' for temporary change and mark 'P' for permanent change in the second column.

Table 3

Action of force	Change in shape [temporary (T)/ permanent(P)]
Stretching rubber band	
Squeezing sponge	
Tearing paper	
Breaking piece of chalk	
Making chapathi	
Breaking glass	

Give some more examples where force can change the shape of an object.

From the above table we can understand that a force not only changes the state of motion of an object but can also change the shape of an object. It may change the shape temporarily or permanently, based on the nature of the object and the force applied on it.

1.9 Pressure

Activity-14

Change in effect of force with area of contact

Take a pencil. Just push its rounded end on your palm. Now push from the other side of the pencil gently so that the sharp end is on your palm. What difference did you experience? Why?

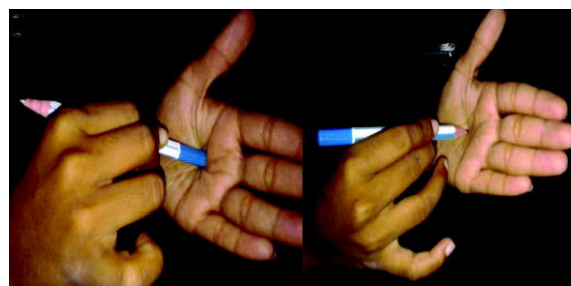

Fig-18

Why do people who carry weights on their heads wear a turban?

Why school bags and shopping bags have wide belts?

Did you ever think why trucks that carry more weight have broader tyres?

In these examples you might have noticed that the effect of force depends on the area of contact on which the force is acting. When there is a decrease in the area of contact of the force or load then the effect of force increases and vice versa.

The force acting perpendicularly on unit area of a surface is called pressure.

$$\text{Pressure} = \text{Force/Area}$$

The unit of pressure in S.I. system is Newton/meter² or N/m².

Activity 15

Identifying effects of force

Take two trays. Fill both the trays with lime powder or fine sand. Now take two rectangular bricks of equal mass and similar shape.

As shown in Fig.-19, drop one brick vertically in one tray and the other brick horizontally in the second tray from certain height. What do you notice?

Do both bricks sink to the same depth in lime powder? If not why?

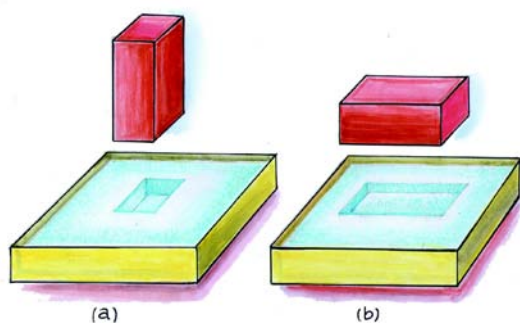

Fig-19

You may notice that the brick standing vertically sinks deeper in lime powder than the brick standing horizontally.

Since the masses of both bricks are similar, the force applied on lime powder by them is the same on both the trays. The difference lies in the surface area of the brick in contact with the lime powder and this is responsible for the change in the extent to which the brick sinks in the lime powder.

In above activity, the contact area on which force is acting is different in each case. The depth to which the brick sinks in the first tray (Fig 19 a) is deeper than that in the second tray (Fig 19 b). This is because

in Fig 19(a), the contact area or the surface area on which force is acting is smaller and hence, the pressure exerted by the brick is more. In Fig 19(b), the contact area or the surface area on which force acting is larger. Hence the pressure exerted by the brick is less.

Why does the sharper side of a knife cuts more easily than the blunt side of it? A sharp side of knife has a smaller contact area. Therefore, for the same amount of force applied on it, the sharp side of knife exerts more pressure than the blunt side and hence cuts more easily.

- Can you give some more examples of pressure?

From the above examples, you can say that for a given force, if the surface area is smaller, the pressure will be greater. If you use a larger area, you are spreading out the force, and the pressure becomes smaller.



Think and discuss

Does pressure have direction? Explain.



Key words

Force, Push, Pull, Contact force, Force at a distance, Field, Friction, Muscular force, Gravitational force, Magnetic force, Electrostatic force, Net force, Magnitude, Equilibrium, Normal force, Tension, State of motion, Pressure, Freebody diagram



What we have learnt?

- Force is a push or a pull.
- A force can act on an object with or without being in contact with it. A force acting on a body is either a contact force or force acting at a distance.
- Field is a three dimensional region. If an object is kept at any point in the field, it will experience the force.
- Friction is the force that opposes relative motion of surfaces in contact.
- The force which we exert by using our body muscles is known as muscular force.
- The attractive force between any two massive objects is called gravitational force.
- The magnetic force attracts a magnetic material such as iron. But it either attracts or repels another magnet.
- The force exerted by a charged body on other charged body is known as electrostatic force.
- Force has magnitude as well as direction.
- The algebraic sum of all the forces acting on a body is known as net force, and is denoted by F_{net} .
- A force can change the state of motion of an object.
- Force may cause a change in the shape of an object.
- The force acting perpendicularly on a unit area of a surface is called pressure.



Improve your learning



I. Reflections on concepts

1. What is a force? What changes can be produced by a Force? (AS₁)
2. Give two examples each for a contact force and a force at a distance. (AS₁)
3. Explain Gravitational Force by giving a suitable example. (AS₁)
4. Draw and explain a free body diagram (FBD) to show all the forces acting on a car? (AS₂)
5. Why do tools meant for cutting always have sharp edges? (AS₁)

II. Application of concepts

1. Explain the differences between a contact force and a force at a distance with examples? (AS₁)

2. Find the net forces from the following diagrams. (AS₁)

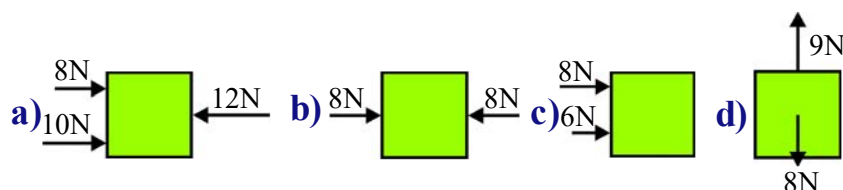

3. A man stand still on a level floor. What forces act on him? Draw a free body diagram (FBD) to show all forces acting on him? (AS₅)
4. The surface area of an object is 20 m² and a force of 10 N is applied on it, then what is the pressure? (AS₇)
5. How do you appreciate the role of friction in facilitating our various activities in our daily life? (AS₆)
6. Identify and draw all forces acting on the body shown in the diagram. (AS₃)

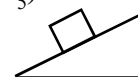

III. Higher Order Thinking Questions

1. If you push a heavy box which is at rest, you must exert some force to start its motion. However once the box is sliding you apply a lesser force to maintain that motion. Why? (AS₁)
2. How do you increase the pressure by keeping (AS₁)
- area unchanged
 - force unchanged
3. Imagine that friction disappeared from the earth. Explain what would happen? (AS₃)



Multiple Choice Questions

1. Hoisting a flag is related to ()
- push
 - pull
 - Push and pull both
 - pressure
2. A person is pulling water from well. Which type of force it is ()
- Muscular force
 - Magnetic force
 - Friction force
 - Electrostatic force

3. The force that a solid surface exerts on any object in the normal direction is called ()
 - a) Muscular force
 - b) Normal Force
 - c) Tension force
 - d) Magnetic force
4. Let the forces F_1 and F_2 act on the table in opposite directions, $F_1 > F_2$, the $F_{\text{net}} =$ ()
 - a) $F_1 - F_2$
 - b) $F_1 + F_2$
 - c) 0
 - d) $2F_2 - F_1$
5. A situation for effect of force leads to a permanent change in shape of object is ()
 - a) Stretching Rubber band
 - b) Squeezing sponge
 - c) Pressing the Spring
 - d) Breaking glass



Experiments

1. Conduct an experiment to find the limiting forces that can be borne by different strings and prepare a report.
2. Design and conduct experiment to test few ways how friction may be reduced.
3. Conduct an experiment to determine the change in effect of force with an area of contact.



Project Works

1. Collect pictures to illustrate contact forces, forces at a distance and prepare a report.
2. Classify the actions in your daily life into
 - (i) actions where we exert force which appears as a push
 - (ii) actions where we exert force which appears as a pull
 - (iii) actions which involve both push and pull
3. Observe the situations of electrostatic forces in your daily life and prepare a report.

We have learnt about the various types of forces in the chapter 'Force'. We also have learnt about the 'force of friction' which plays an important role in daily life. Let us learn in detail about frictional force in this chapter.

2.1 Force of friction and its Types

Activity -1



Identifying forces acting on a body and effect of frictional force



Fig-1: Pushing the book

Gently push a book on a horizontal floor as shown in fig.1 and then leave it.

- What do you observe?

You may observe that the book acquires a certain speed in the direction of push. However, the speed of the book gradually decreases and after some time it stops.

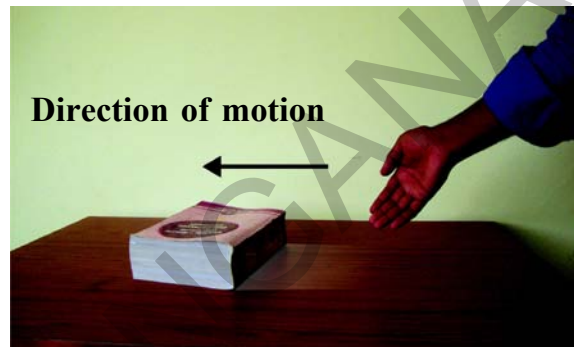

Fig-2 : The book acquires a speed

- Why does the book stop after covering some distance?
- Is the book moving with uniform speed?
- Why does the speed of the book change gradually?

You know that the book is in non-uniform motion with respect to the floor. In the "Force" chapter we studied that non-uniform motion of a body takes place only when a net force acts on it.

- How many forces act on the book when it is pushed on the floor?

Let us observe the forces acting on the book.

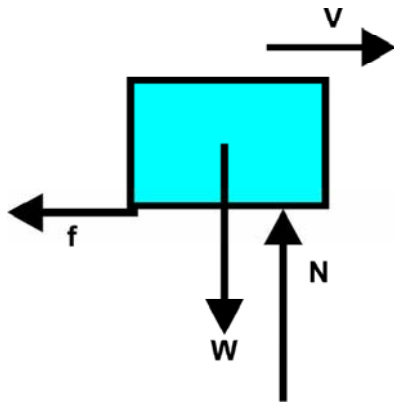

Fig-3: Forces acting on the book

Two forces act on the book in the vertical direction as shown in fig-3.

They are,

- (i) Weight of the book (W) or gravitational force acting vertically down.
- (ii) Normal force (N) or reaction force applied by the floor vertically up.

As there is no change in motion of the book along the vertical direction, the net force acting on the book in the vertical direction is zero. That is,

$$W - N = 0 \Rightarrow W = N$$

In the horizontal direction, the speed of the book is changing continuously. Its speed is decreasing gradually in the horizontal direction i.e., the book has acceleration opposite to the direction of motion (which we call deceleration).

- What are the forces acting on the book in the horizontal direction?
- What is the net force acting in the horizontal direction?

When the speed of the body moving in a straight line changes continuously, we say that the body has acquired an acceleration.

By close observation of this activity, we can understand that the floor

applies a force on the book against its motion. Similarly the book also applies the same amount of force on the floor in the opposite direction. Here it is clear that the floor is at rest. Hence the net force acts in the direction of the force applied by the floor on the book.

The force applied by the floor on the book is called **“frictional force”** or **friction**.



Lab Activity



Aim: Understanding the nature of friction and the concept of static friction.

Material required: Toy Trolley, small wooden block, inextensible string, weights, pulley weight hanger, and a long table.

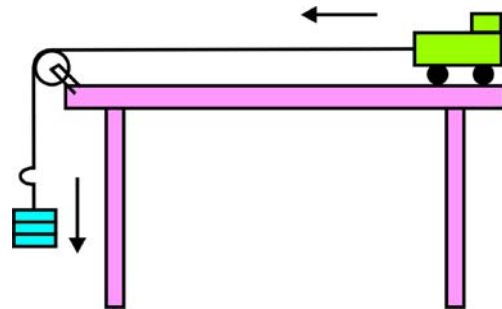

Fig-4: The trolley accelerating towards left

Procedure: Take a small toy trolley and keep a small wooden block on it as shown in fig-4.

Tie an inextensible string to the trolley and pass it over a pulley. And other end of the string is fixed to weight hanger.

Take a small weight and keep it on weight hanger and observe the changes in

- What happens to the position of the block kept on the trolley?
- Does it fall or move along with the trolley?
- What changes occur in the motion of trolley and wooden block?

You will notice that the trolley with the block on it moves towards left with an acceleration. The block is at rest with respect to the surface of the trolley, but it is in motion with respect to the surface of the table.

Now keep on increasing the weight on the hanger. Observe the motions of both trolley and block.

Here the surface of the trolley tries to keep the block at rest here with respect to its surface. The force of friction by the surface of the trolley acts on the block in the direction of motion. At the same time the block also applies a force on the trolley in opposite direction and tries to move towards the right.

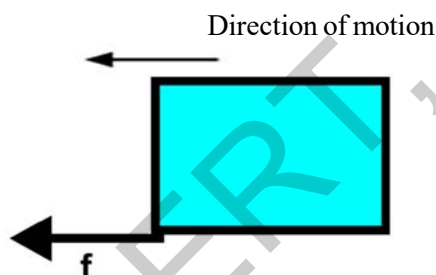

Fig-5: The direction of friction on the block.

We can increase the trolley's acceleration by increasing the weight on the hanger. If we increase the acceleration of trolley gradually, at certain 'limiting weight' or 'limiting acceleration' the block comes into motion in the reverse direction. This means that now there exists relative motion between the surface of the trolley and the block.

- What happens when the experiment is repeated by using rock and iron blocks of the same mass; and by using rock and iron blocks of different masses?
- Does the limiting weight change? If so, why?

Apply some grease to the bottom of the wooden block and keep it on the trolley's surface and do the same experiment.

- Is there any change in the limiting weight?
- What should we do to increase the limiting weight?

From the above activities we may define friction as follows,

The force which opposes the relative motion of two surfaces of bodies in contact, is called 'frictional force'.

In activity-1, the book moves with respect to the floor. So, this friction is called sliding friction.

Sliding friction is the friction which comes into play when the surface of one object moves relative to the surface of another object.

In lab activity, the block is at rest relative to the surface of the trolley up to a certain limiting acceleration. The friction exists at this stage is a static friction.

So, **static friction** is the friction which comes into play when surfaces of the objects are at rest relative to each other even though there is an external force acting on them.

In the above lab activity we observe that there exists two types of frictional forces at a time. One is friction between surface of the table and trolley, and the other is the static friction that exists between the surface of trolley and wooden block kept on it.

2.2 Observing the variation of friction

Activity-2

Push a heavy box which is kept on a floor with a small force to move horizontally as shown in fig-6. The box does not move because there is a frictional force which is equal and opposite to the applied force on the box.



Fig-6: Pushing a heavy box with small force

Now gradually increase the applied force, the box still does not move. The applied force, frictional force both are equal and opposite because the frictional force also increases accordingly and thus balances the increased applied force.

From this experience we conclude that static friction is a self adjusting force.

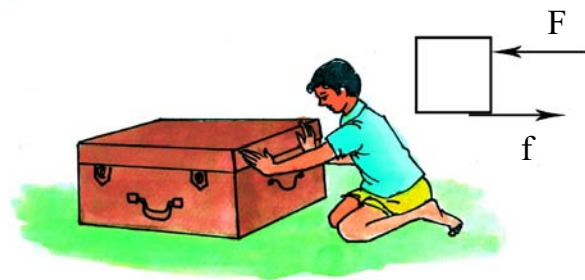

Fig-7 : Pushing a heavy box with increasing force.

But there is a limit to this static friction. As you keep on increasing the applied force, at some point the box starts moving. That is, when the applied force is more than the limit of the static friction, the body starts to move as shown in fig-8.

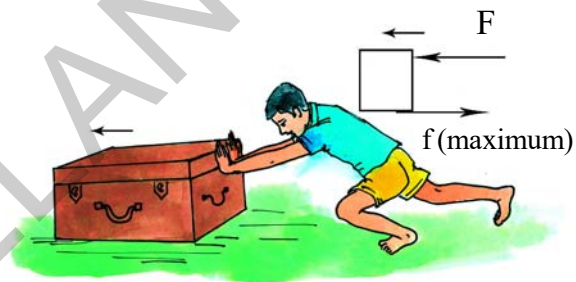

Fig-8: The heavy box starts moving

When the box is sliding on the floor, the friction between them is called sliding friction.



Think and Discuss

- Does friction oppose motion or relative motion of surfaces in contact? Discuss.
- What observations and experiments can you cite to show the existence of friction?
- When do we speak of "sliding friction?"

2.3 Factors affecting friction

Activity-3



Effect of roughness on frictional force

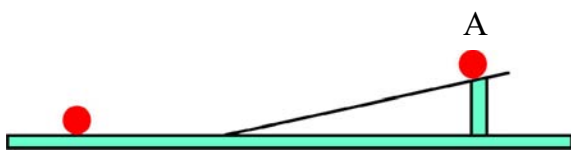

Fig-9: Motion of a Ball on an inclined plane.

Set up an inclined plane on the horizontal floor. Use a wooden board as inclined plane. Put a mark 'A' at any point on the inclined plane. Now let a glass marble or ball move down from this point. Note the distance covered by the glass marble from the bottom of the inclined plane to point where it comes to a stop.

Now, spread a cloth over the floor. Make sure that there are no wrinkles in the cloth. Try again with glass marble or ball. Now measure and note down the distance.

- What are your observations from these experiments?
- In which case is the distance covered maximum?
- In which case is the distance covered minimum?

- Why is the distance covered by the glass marble or ball different on different surfaces? Discuss the result.

If you do the above activity by replacing the cloth with white marble surface or glass surface, can you predict the distance covered by the glass marble? You can conclude that smoothness / roughness of the surfaces of both the floor and the glass marble could affect the distance travelled by it.

Though many surfaces look like perfect planes, there exists many ups and downs on them. That type of surfaces are called irregular surfaces. Friction is caused by the irregularities on the two surfaces which are in contact.

Irregularities on the two surfaces lock into one another, when we attempt to move on any surface. We have to apply a force to overcome interlocking. On rough surfaces, there exist a large number of irregularities (ups and downs). Hence, the force of friction is greater if a rough surface is involved.

Activity-4

Effect of area of contact on frictional force

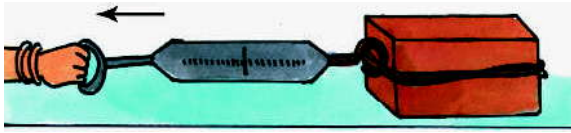

Fig -10: Pulling a brick with spring balance

Tie a string around a brick and pull the brick by using a spring balance as shown in fig-10. We use spring balance as a device to measure the applied force.

In a spring balance, the spring is stretched by the applied force. The change in the length of the spring is proportional to the applied force. So the scale of the spring balance directly gives the applied force in Newtons and in some spring balances the force is given in kilogram-weight also.

Pull it to move the brick. Note down the reading of spring balance when the brick just begins to move.

- How many forces do act on the brick in the horizontal direction?

Two forces act on the brick in the horizontal direction as shown in fig-11 .

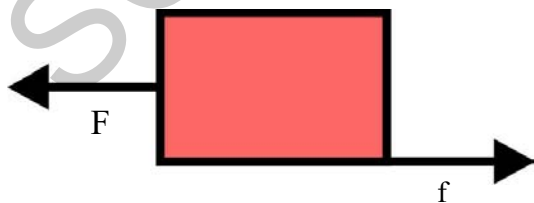

Fig-11: Horizontal forces on the brick

One is the force applied (F) by you and the other is force of friction (f). The applied

force is equal to the maximum limit of the frictional force at the instant when the brick just begins to move. But they act in opposite direction. You can note down its value by observing the reading of the spring balance. In this way we can measure the maximum frictional force offered by the surface.

Now turn the brick upright as shown in fig-12 so that the contact area with the floor becomes small. Repeat the same experiment and measure the friction using the spring balance.

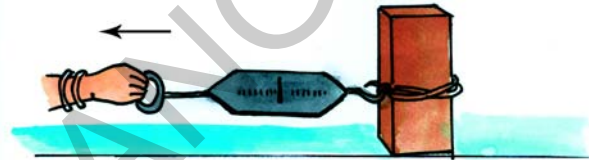

Fig-12: Pulling same brick with another orientation

- How does the frictional force vary with the change in the area of contact?

The frictional force appears to be the same in both cases irrespective of area of contact of the surfaces.

Activity-5

Effect of normal force on friction

As in the activity-4, keep a brick on the horizontal floor and pull it with the spring balance attached to it and measure the frictional force. Now put another brick over the brick tied to the spring balance or press it vertically with your hand and then measure the force of friction as described above.

- Is there any difference between frictional forces in two cases? If yes, why?

From the above activity you can understand that there is a change in the values of frictional force. Frictional force is increasing.

When we add a brick to the existing brick or apply a force by pressing it vertically, the normal force increases and hence, we find there is an increase in the frictional force. So, Friction is proportional to the Normal force i.e.,

$$\text{Friction} \propto \text{Normal Force}$$

(where \propto is the symbol representing “proportional to”)



Think and Discuss

- Does friction act on a table resting on the floor?
- If normal force is doubled, what happens to friction? Discuss.
- Your friend says, “Friction depends on the area of contact”. How do you correct your friend through some experiments?
- “Friction is independent of weight, but depends on normal force between surfaces of contact where friction exists”. Do you agree with this statement? Discuss.

2.4 Is friction necessary?

Have you ever tried to walk on muddy or slippery surface. Why do you find it difficult to walk on slippery surfaces? We cannot walk or run without friction.

Let us see the things that will not happen in the world if friction was not present. We will not have any cars, bicycles or scooters. All of them move only because of friction. Even if somebody pushes a car, we will not be able to stop it by applying brakes.

Carpenters will not be able to smoothen surfaces.

You will not be able to hold any appliances such as hammer, soap etc.

It will not be possible to write with pen or pencil if there is no friction.

You would not be able to fix a nail on the wall.

No building could be constructed if there were no friction.

All the above examples tell the importance of friction. On the other hand friction is undesirable too in the machinery. For instance, friction is responsible for overheating and wearing out of moving parts. You need to apply oil or grease to your bicycle parts in order to make it move smoothly.

Make a list of few more examples of the situations where we need to reduce friction for efficient functioning of tools.

Activity-6

Friction produces heat



Fig-13: Rubbing the hands



Fig-14: Striking a matchstick against the surface of matchbox

- Rub your palms against each other for a few minutes. How do you feel?
- Strike a match stick against the rough surface of match box. What happens?

In both the activities we observe because of the friction, temperature of the surfaces increases. Matchstick catches fire because of increase in temperature by friction. Thus, we can conclude that friction can produce heat.

Give some more examples where friction produces heat.

You have probably heard that space craft returning to the earth has to be protected by a heat shield covering it. Find out why? What is the material used as the 'heat shield'?



Think and Discuss

- What important role does friction play in the life of human being and animals?
- Why is friction important for transport?

2.5 Increasing and decreasing friction

Activity-7



How to reduce friction?

Take a spoon and hold its head (broader portion) in the left hand and hold the mid portion of the spoon by the right hand and pull it towards the other end of the spoon.

- What do you notice?
Now dip your right hand fingers in water, do it again as said above.
- In which case it is easy to pull? Why?

Repeat the activity with other liquids such as coconut oil, grease etc and observe the difference.

Friction can be advantageous in some cases and disadvantageous in other cases. In the former case of activity 7 you will find that the friction is more, in the latter case, friction is reduced.

Let us try some examples.



Fig-15: Bottom of the shoe

- Have you ever thought why the sole of your shoes is grooved as shown in fig-15?

It is done to provide the shoes better grip on the floor, so that you can move safely. Similarly, the tyres of cars, trucks and bulldozers are treaded (fig-16). Why?

- Why do you need to change the tyres when it's treading is worn out?



Fig-16: Pattern of tyre

Gymnasts apply some coarse substance on their hands to increase friction for better grip.

In some situations, however, friction is undesirable and we would like to minimize it.



Fig-17: The carom board

Play carom board without powder and then play with fine powder sprinkled on the board.

- In which case is the movement of the striker and the coins easy? Why?
- Why do we apply a few drops of oil on the hinges of a door?

- Why do we use grease between the moving parts of motor vehicles?

In all the above cases, we want to reduce friction in order to increase efficiency.

When oil, grease or any other lubricants are applied between the moving parts of a machine, a thin layer is formed between the moving surfaces and hence they do not directly rub against each other. Interlocking of irregularities is avoided to a great extent by the application of lubricants. Hence movement becomes smooth.

The substances which reduce friction between the moving parts of a machine are called "Lubricants"

Activity -8

Effect of rollers on friction



Fig-18: Pulling suitcase with rollers

Pull a suitcase without rollers and pull a suitcase which has rollers.

- In which case pulling is easy? Why?

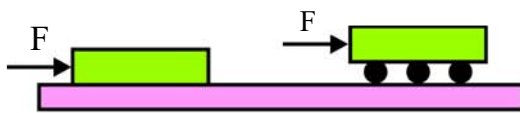

Fig-19: Pushing a book on pencils

Try to push a book lying on the table. Now place the book on two to three pencils or pens without caps. Push the book again.

- What do you notice? Why?
- In which case it is easy to pull the book? Why?

It is always easier to roll a body than to slide it over a surface. So it is convenient to pull the suitcase fitted with rollers. When one body rolls over the surface of another body, the friction offered is called **rolling friction**.

Activity-9

Understanding the principle of ball bearings



Fig-20: Rotating the lids

Take two lids and rotate them by putting one on the top of the other. What do you observe? Now place four to five marbles on one lid and place the other lid on the top of the marbles. Then try to rotate the top lid. What do you observe?

This is the principle of ball bearings.

To reduce friction between rotating shafts of machine tools, we use “ball bearings”.



Think and Discuss

- Can we reduce friction to zero? Explain.
- What purposes are served by ball bearings in machines? Explain with daily life situations.

2.6 Fluid friction

Activity -10

Observing fluid friction



Fig-21: Stirring water



Take a glass of water and stir it with a spoon. You know that water whirls around an axis. Stop stirring and see what happens. You may notice that whirling speed of water gradually decreases and after some time, the water comes to a stable state.

- Which force is responsible for stopping the rotation of the water?

The frictional forces between the liquid layers and between the liquid surfaces that is in contact with glass surface are responsible for stopping the rotation of the water.

Similarly water and other liquids exert force of friction when objects move through them.

You can observe fluid friction when you travel in a boat.

Not only liquids, gases and air also offer friction to bodies like aeroplanes, jets when they move through air.

In science, the common name for gases and liquids is 'fluids'. So, we can say that fluids exert force of friction on objects in motion through them. The frictional force exerted by fluids is also called "drag".

Activity-11

Identifying the factors influencing the fluid friction

Take a tub of water. Try to move your hand in water in the direction of stretched fingers (up and down). Now try to move your hand in the direction perpendicular to the plane of the hand (to and fro).

- In which orientation of your hand, do you experience more drag? Why?

Frictional force on an object in a fluid depends on its speed with respect to fluid, on the shape of the object and on the nature of the fluid.

It is obvious that when objects move through fluids, they have to overcome friction acting on them. So efforts are made to minimize friction. Objects are given special shapes. Where do you think scientists get hints for these special shapes? From nature, of course.



Fig-22: Bird and Aeroplane

Birds and fishes have to move about in fluids all the time. Their bodies must have evolved to shapes which would make them not to lose much energy in overcoming friction.

Do you find any similarity in the shape of an aeroplane and a bird? In fact all vehicles are designed to have shapes which reduce fluid friction.



Key words

Friction, Static Friction, Sliding friction, Lubricants, Rolling friction, Ball bearings, Drag, Fluid Friction.



What we have learnt?

- Friction opposes the relative motion between two surfaces in contact. It acts on both the surfaces.

- Static friction comes into play when we try to move an object that is at rest on a plane surface.
- Sliding friction comes into play when an object is sliding over another.
- Friction depends on the nature of surface and the normal force with which the body presses the other surface.
- Friction can be reduced by using lubricants and ball bearings in many machines.
- When bodies move through fluids, fluids exert a frictional force called drag.



Improve your learning



G72TJZ

I. Reflections on concepts

1. Explain the types of friction with suitable examples (AS₁)
2. A book is placed on the surface of a table. The book is pushed in one direction. Draw the forces acting on the book and explain. (AS₃)
3. Give few examples for Sliding friction. (AS₁)
4. Explain how does lubrication reduce friction. (AS₁)
5. Explain with one example that frictional force is proportional to the normal force (AS₁)

II. Application of concepts

1. Explain why do sportsmen use shoes with spikes (AS₁)
2. Would it be easier or difficult for you to walk on a marble floor with soapy water. Why? (AS₁)
3. What happens if we do not reduce friction in machines? (AS₂)
4. What purposes are served by using ball bearings in machines? Explain with daily life examples. (AS₇)
5. Draw a free body diagram (FBD) to show various forces acting on a body which is sliding on an inclined plane. (AS₅)

III. Higher Order Thinking Questions

1. Do you agree with the statement. "friction is both good and evil." Explain with examples. (AS₁)
2. Reducing friction to the lowest possible level in machine tools solves the problem of energy crisis and conserve biodiversity. How do you support the statement? Explain? (AS₇)



Multiple Choice Questions

1. Which material do gymnasts apply on their hands to increase friction for better grip ()
 - a) Oils
 - b) Soap
 - c) Coarse substance
 - d) water
2. The relation between the change in the length of spring and the applied force is ()
 - a) Inversely proportional
 - b) Equal
 - c) Directly proportional
 - d) Never depends on the force
3. The bodies of birds and fishes must have evolved to shapes which would make them not to lose much energy in overcoming ()
 - a) Rolling friction
 - b) Static friction
 - c) Sliding friction
 - d) Fluid friction
4. Which of the following friction has self adjusting force ()
 - a) Sliding friction
 - b) Static friction
 - c) Rolling friction
 - d) Fluid friction



Experiments

1. Conduct an experiment to understand the nature of friction and the concept of Static friction and prepare a report.
2. Conduct an experiment to findout the effect of roughness on frictional force and prepare a report.



Project Works

1. Collect information about various new techniques being adopted by human beings to reduce energy losses due to friction.Prepare a report on it.
2. Collect information about the substances using to reduce the friction in different machines and prepare a report on it.

In previous classes, you were familiar with different types of fibres. You know that clothes can be made from natural fibres such as cotton, silk and wool (figure-1). You also learnt how they are prepared.

3.1 Clothes made of natural fibres

We wear a wide variety of fabrics in our daily life.

- Are all of our clothes made of natural fibres?

You might have heard about fabrics such as polyester, nylon and acrylic etc. They are examples of synthetic fibres.

- Why do we call them synthetic?

Synthetic fibres are not obtained from plant or animal source. They are made by the raw materials obtained from petroleum. Synthetic fibres are used not only for fabrics but also in preparing many household articles.



Fig-1: Clothes from Natural Resources

Activity-1

Identify household articles made up of natural and synthetic fibres.

Identify the articles made of fibres at your home, school and in your surroundings and write their names against relevant category in table-1.

Table -1

Source	Articles / Object
Natural fibres from plants	cotton saree,
Natural fibres from animals	silk saree,
Synthetic fibres

What do you observe from the list made by you?

You notice that the list of household articles made of synthetic fibres is very long. It encompasses all our day to day activities.

What do you know about synthetic fibres? How are they manufactured? Let us discuss synthetic fibres in detail.

What is synthetic fibre?

Have you seen a bead necklace? Do you observe any pattern in arrangement of beads? see (Figure 2 (a)) Can you describe the pattern?



Fig-2(a):
bead necklace



Fig-2(b):
single paper clip



Fig-2(c):
paper clips chain

Activity-2

Beads and paper clips pattern

Take a few paper clips (Figure 2(b)) and join them together as shown in figure 2(c). Observe the pattern of clips. Do you find any similarity between the pattern of beads in necklace and the pattern of paper clips in the chain?

Each unit of paper clip or bead can be joined together to form a long chain like structure. Each bead (or clip) is a separate unit but when many such units are joined together, they form a new, different structure.

Similarly, synthetic fibres are made of chain like structure which are themselves

formed by joining small units together. Each small unit in the chain is known as monomer units. Many small, identical units monomers combine to form a large unit called **polymer**. Synthetic fibres are made of polymers.

Unlike natural fibres, synthetic fibres are made from petroleum based chemicals or petro chemicals. Petrochemicals are subjected to various chemical processes to obtain synthetic fibres. Due to this, they are called **Synthetic fibres** or **artificial fibres**.



Do you know?

What does Polymer mean?

'Poly' means many and 'mer' means part/unit. The word is derived from Greek. So we can say polymer is a structure made up of many small repeating units.



Think and Discuss

- What made the human beings to search for the alternative for natural fibres?
- Which fibre source is not exhaustible? Why?

3.2 Some synthetic fibres

How do you find whether a fabric is synthetic or not? Take a piece of cloth and pull out a thread. Unravel this thread (yarn). How long is the fibre? Is it lustrous or not? Do these characteristics help in identifying a fibre?

You can't identify the fibres by simple visual inspection alone in the absence of brand label. Then how to identify them? Let us see.

Activity-3

Identifying fibres – burning test

You can do a fibre burning test. Unravel several warp and weft yarns. Using tweezers hold the yarn to the edge of a flame. Observe the changes.

- If it smells like burning hair, the yarn is wool or silk.
- If it smells like burning paper, the yarn may be cotton, or rayon.
- If the yarn melts in the flame, it is a synthetic fibre such as nylon and acrylic.

You had learnt in the previous classes how natural fibres are obtained and fabrics are made from them. Do you know how various synthetic fibres are obtained? Let us learn about it.



Think and Discuss

How synthetic fibres evolved to the present position?

3.2.1 Nylon

Can you name few synthetic fabrics that you wear? Have you ever heard of nylon?

Nylon is a synthetic fibre. It is prepared from coal, water and air. It was the first fully processed synthetic fibre. It became popular during the Second World War, now

a days Nylon replaced silk in most hosiery articles such as stockings.

How is nylon made?

Nylon is a polymer made of chemical units called 'polyamides'. Polyamides are made with monomers, hexamethylene diamine and adipic acid. Solid chips of these polyamides are melted and forced through a heated spinneret which has very, very tiny holes.

The size and shape of the holes change, the characteristics of the resulting fibre. The fibre solidifies as it cools and can be spun or woven.

Have you ever heard a crackling sound when you take off certain types of clothes? Or did you see sparks in them when it is dark? This is due to static electricity. Learn from your teacher about it.

Nylon fibre is strong, elastic and light in weight. Clothes made of Nylon are lustrous and easy to wash. So it has become very popular. Nylon does not absorb water - this fact explains many of its uses. But static electricity is easily created in nylon fabrics. It also easily catches fire. So we should not wear nylon clothes while cooking, welding, working near a fire or using heavy machineries.

- Why do we wear apron during cooking or working near the fire?

Many articles that we use in our daily life are made up of nylon.

Can you name a few things made of nylon?

Tooth brush bristles, ropes, fishing nets, tents, sarees, stockings and socks, car seat belts, sleeping bags, curtains etc, are made of nylon.

Can you add some more articles to this list?



Fig-3: Articles made of nylon

Nylon has replaced wool as the fibre used in making carpets. Nylon is also used in making parachutes. Rock climbers use nylon ropes to climb mountains. It is used in making of swim suits, sheer hosiery, sails, umbrella cloth, dress materials, car tyres, etc.



Fig-4: Use of Nylon Fibres

Why nylon is preferred to make a good parachute or a climbing rope? Let us find out!

Activity -4

How strong is nylon?

Take an iron stand with a clamp. Take cotton, wool, nylon and silk threads about 50cm in length. Tie cotton thread to stand so that it hangs freely from it. At the free end, attach a pan so that a weight can be placed on it (Figure 5). Add weights starting from 10 grams one by one, till the thread breaks down. Note down the total weight required to break the thread. Repeat the same activity with threads of wool, silk and nylon. Fill the data in table 2. (Precaution: Note that all the threads should be of the same length and almost of the same thickness.)

Table 2

S.No.	Type of thread/ fibre	Total weight in gr or kg required to break the thread
1	Cotton	
2	Wool	
3	Silk	
4	Nylon	

Arrange the threads in order of their increasing strength. What do you observe from the above activity?

Do you know that if you compare a nylon thread with a steel wire of same thickness, nylon will be as strong as steel wire?

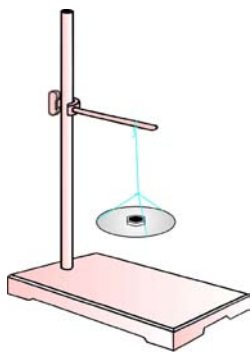

Fig-5: An iron stand with a thread hanging from the clamp



Think and discuss

- If we use cotton cloth and cotton ropes in preparing a parachute, what will happen?
- Traditionally fishermen used cotton nets. Now they are using nylon nets. What is the advantage of using nylon nets?
- Nylon sarees are better than the cotton sarees. It is better to use only nylon sarees. Do you agree with this? Why?

3.2.2 Rayon

We know about natural silk which is obtained from silkworms. Fabrics made of silk are very costly. It is not even accessible to all. Production and maintenance of silk clothes are also very difficult and time taking process. But its texture fascinates everyone.

For many years scientists attempted to make silk artificially and their efforts were successful towards the end of the nineteenth century. The first commercial production of artificial silk was achieved in USA in 1911. But this fibre was named as rayon only in 1924. The first rayon factory in India was established in Kerala in 1946.

- Where do we find rayon factories in our state? Discuss with your teacher.

Let us now discuss how rayon is prepared.

How rayon is made?

We noted that petrochemicals are the source material for many polymers and synthetic fibres. But the source material for rayon is wood pulp. It is the only synthetic fibre obtained from plant's cellulose and so it is called cellulose fibre.

If rayon is obtained from plant cellulose then why don't we call it as a natural fibre? Let us find out the process of preparing rayon to decide whether rayon is natural or artificial.

The cellulose that was collected from wood or bamboo pulp, is treated with several chemicals. First sodium hydroxide is added and then carbon disulphide to the cellulose. The cellulose dissolves in chemicals, added to it and gives a syrup called **viscose**. Viscose is forced through a Spinneret (Metal plates with very, very tiny holes) into a solution of dilute sulphuric acid. This gives us silk like threads. The threads are cleaned with soap and dried. This new fibre is called **rayon**. What do you say now. Is rayon natural fibre or artificial? Some kinds of rayons are made from the short cotton fibres left on cotton seeds after ginning.

Rayon is cheaper than silk and can be woven like silk fibre. It can be dyed in a

- Is rayon used only for clothes?
- What are the other things that are made from rayon fabric?

Rayon is mixed with cotton to make bed sheets. Rayon is mixed with wool in making of carpets. Rayon is often used in fashion and home furnishings. Rayon is also found in sanitary products, diapers and bandages and lints for dressing wounds (Fig.-6).

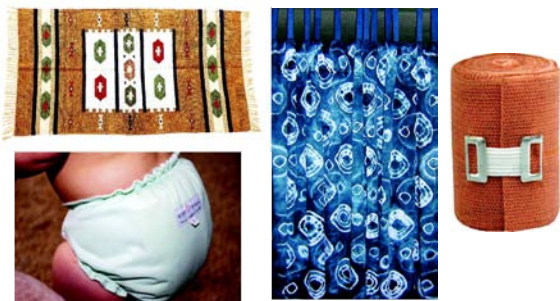

Fig-6: Articles made from rayon.

Rayon is not a perfect fibre to prepare all fabrics because it is made from plant cellulose, it absorbs water easily. Absorbing water makes rayon weak and causes the fibre to break easily.

Think and Discuss

- What characteristics make rayon better than natural silk?
- If you want to purchase a door mat made of synthetic fibre, which synthetic fibre door mat will you select? Why?
- If sanitary diapers and bandages are made of nylon, what will happen?

Activity-5

Why do we combine fibres?

Whenever you buy clothes or readymade garments observe the brand label. What do you notice? Or, visit a nearby garment shop and look at the labels on the cloth see Fig. - 7.

Record the percentage of different fibres mentioned on the labels. You may find rayon mixed with wool and cotton, polyester mixed with cotton and wool. Even Nylon is mixed with polyester. Why do we combine fibres? What is this process called?

(Here, we just introduced a new word 'polyester'. You will learn about this in detail in later part of this chapter).



Fig-7: Labels showing different percentages of blend

Any synthetic fibre can be combined with two or more other fibres. This is called **blending**. Natural and synthetic fibres are often blended for preparing better fabric. A blend does not simply mean alternating threads of cotton and polyester. Unique and different

When a fibre is combined with other fibre, certain qualities of first fibre are combined with the qualities of other fibers and give us a blended fabric which possess the best qualities of both. Blending helps us to reduce the limitations of both fibres. For example, if you consider cotton and polyester blend, cotton is comfortable to wear but it forms wrinkles. But polyester is wrinkle free. Therefore when these two are combined, the end result is a comfortable and wrinkle free fabric. Cotton shrinks in wash while polyester generally does not. So when these two are combined in a proper ratio, the resultant material does not shrink to a large extent when compared with a pure cotton fabric.

The more the percentage of natural fibre in blending of fibres, the more would be the comfort to the skin. When natural fibres contribute to a fabric, it allows the skin to breathe easily. Also natural fibres are generally free from irritating chemicals.

3.3 Acrylic

What type of clothes do you wear in winter? All of us wear clothes which keep our body warm. We use sweaters, shawls or blankets. People feel that all these are made up of natural wool. Wool is very expensive and generally is not affordable and accessible to everyone. Think! How many sheep would be needed to obtain the wool to prepare sweaters for everyone in India?

All the winter wear nowadays is made of a synthetic fibre called *acrylic*. It became commercially available in 1941.

It looks like natural wool. It can be considered as artificial wool. It is generally called '*fake fur*'.

It is made from petrochemicals. It is spun by either dry spinning, or wet spinning. In dry spinning the dissolved polymers are extruded into warm air. The fibres solidify by evaporation. In wet spinning, the polymers are dissolved and extruded into a bath and then dried out. The wool obtained from natural sources is quite expensive, whereas clothes made from acrylic are relatively cheap. Can you give examples for the things made up of acrylic?

It is used in knitted apparels such as socks, sportswear and sweaters. It is also used in craft yarns, upholstery fabric, carpets, luggage awnings and vehicle covers.

- Do you have any of them in your home?



Think and Discuss

- Which type of blended fabrics do you find more comfortable in winter? Why?
- The fabrics namely natural, synthetic and blended are available for garments. Which fabrics will you prefer to wear for rare occasions like functions and in routine? Why?

3.3.1 Why synthetic fibres?

What kind of umbrella would you use on a rainy day? Would you use an umbrella made of cotton or wool?

We have learnt about three different synthetic fibres. How are they different from natural fibres? Synthetic fibres absorb less water and dry at a faster rate. Some are even water proof. Most of them possess several unique characteristics. They are durable, less expensive, readily available, affordable and are easy for maintenance.

In activity 3, when you burn synthetic fibre you find that their behaviour is different from that of natural fibres. Synthetic fibres melt on heating. This is the disadvantage of synthetic fibres. If the synthetic fabric catches fire, it can be disastrous. The fabric melts and sticks to the body of the person who wears it. So we shouldn't wear the synthetic clothes while working in the kitchen or in a laboratory. Washing and ironing also different for synthetic clothes. Have you ever observed the labels given in the figure-8 on the collars of your shirts or inside the frocks and trousers? What does it indicate?

collect some labels and discuss with your teacher about the symbols they represent.

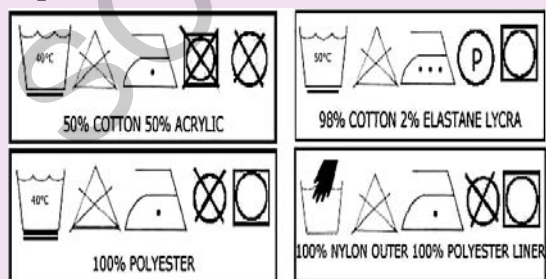

Fig-8: Laundry label codes

Symbols showing precautions to be followed while washing and ironing.



Think and Discuss

- Which fabrics do you prefer? Natural or synthetic? Why? Discuss comparatively.
- What is the difference between washing of clothes at home and washing by dry cleaning at laundry?

3.4 Polyesters

You might have heard about polyester and terylene clothes. What type of fabrics are they?

Polyester is the most commonly used synthetic fibre. Polyester fibres revolutionalized the fabric industry and changed the costume culture. Fabric made from polyester fibre doesn't get wrinkled easily. It remains crisp and is easily washable. So it is quite suitable for making dress material. Terylene is a popular polyester. It can be drawn into very fine fibres. That can be woven like any other fibres. This fibre blends well with natural fibres. Terylene is often mixed with cotton to make **terricot** and with wool to give **terriwool**. Like nylon, pure polyester or terylene easily catches fire.

Polyester is made by reacting, terephthalic acid to di-methyl ether, then with dihydric alcohol. Polyester can be melted and spun. This property allows the fibre to convert into different shapes and sizes. Polyester fibres of these days are ultra thin microfibers which gives them a smoother, softer feel.

This base material can be used to make not just fibres for fabric but many other things: from soda bottles to boats.

Have you seen or heard of PET bottles? PET is a very familiar form of polyester. It is used for making bottles, utensils, films, wires and many other useful things.

3.5 How can you say a bottle is PET bottle?

Activity-6

Collect different kinds of water bottles of your classmates and look at them carefully. Do you observe any triangle shaped symbol at the bottom of the bottle or on the brand label sticker? What number is marked in the center of the triangle? Look at figure 9. You will find that many of the bottles will have 1 in the center of the triangle. If it is 1, then it is a PET bottle.



Fig-9 : Resin identification codes

Code Numbers:

1. Polyethylene Terephthalate (**PET, PETE**)
2. High Density Polyethylene (**HDPE**)
3. Vinyl (**Polyvinyl Chloride or PVC**)
4. Low Density Polyethylene (**LDPE**)
5. Polypropylene (**PP**)
6. Polystyrene (**PS**)
7. **Other** (The category of “Other” includes any resin not specifically numbered 1, 2, 3, 4, 5, or 6, or combinations of one or

Activity -7

Identification of various articles with recycling codes

Collect bottles of soft drinks (500 ml or more), bottles of juice, and containers of fruit jam, Ketchup, shampoo, coffee powder and try to look for the triangle. What do you notice? What are these codes? What is the use of these codes? Are all bottles found with codes?

First look at the soft drinks and juices. You may observe that irrespective of the brand name, the number 1 is marked in the middle of the triangle. It indicates that it is a PET bottle. What about other bottles? There are other numbers as shown in figure-9.

- Where do you find these codes?

Explore from various sources and try to know more about coded articles.



Do you know?

Why are soft drinks stored in these PET bottles? Soft drinks are carbonated so they should be stored in containers with which they will not react.

Plastics around us



Observe various articles around you, in your house, kitchen, rooms, and bathrooms. What is the most common material used in making these objects?

Milk and oil pouches, containers to store pickles and rice, buckets to store water, chairs, water pipes, electric appliances, television, radio and computers, mobile phones—everything seems to be made of plastic.

Talk to the elders in your family about the materials they used in the past. Particularly, what do they think about buying water in polythene pouches? What did they use to bring milk, oil, other liquids from shop to home in the past? What were the containers, buckets, mugs, chairs and tables used in the past made of? What do we use to make these articles nowadays?

Plastic has taken over the place that occupied by metals and wood earlier. Plastics have also replaced glass items. If we continue to write the list, it will be endless. Plastics completely occupied our life because of their characteristic properties.



Fig-10: Articles made of plastics

3.6 What is plastic?

Plastic is also a polymer like many synthetic fibers we have studied so far. But the monomers in plastic can be arranged in two ways. Some are in linear chains (Fig. 11 a) and others cross linked (Fig.- 11 b).

Plastics are available in different shapes and sizes. They have a wide variety of uses. We also observed that they have different code numbers as mentioned in activity-6. Does the arrangement of monomer units in plastics has any relation for this diversity in plastics?



Fig-11(a): Linear arrangement of monomers

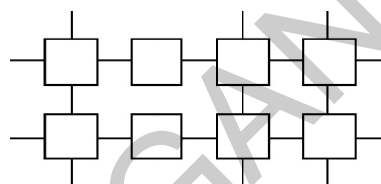

Fig-11(b): Cross-linked arrangement



Do you know?

Alexander Parkes (1813-1890) - Creator of first Plastic -

“Parkesine” One of the many triumphs of modern science which is



completely encompassed the day to day life across the world is the invention of plastics. The synthetically produced material was first presented in 1862 in London by Alexander Parkes. To prepare this material Parkes heated nitrated cotton which previously soaked in sulfuric acid and made fabric soft and elastic with oil and camphor. The end product was an ivory – colored material that became distorted when subjected to heat. This is named as **Parkesine**. Based on these initial efforts plastic evolved as main base for many modern materials. But at that time people were not interested on this alternative to natural substances. Now it is the basis for most of the modern materials.

3.7 Types of Plastics

Activity-8

Let's take two bottles made up of plastic. One is PP bottle and another ordinary PET. Pour some hot water in both. What changes do you notice? Have you experienced such instances in your daily life (Figure 12). See the code of the bottle that gets deformed

Plastics which get deformed easily on heating and can be bent are known as **thermoplastics**. Some of the thermoplastics are polythene and PVC. These are used in manufacturing toys, combs and various



types of containers. There are some plastics which moulded once can't be softened by heating. They are called **thermosetting plastics**. Bakelite and melamine are examples for this type. Now can you tell whether PP is thermosetting plastic or thermoplastic?

Thus we can conclude that different types of plastics have different properties. Plastics are easily mouldable, can be converted into any shape, can be recycled, reused, coloured, melted and rolled into sheets and wires. Do all kinds of plastics show the above properties? Let us see.



Lab Activity

Aim: Identifying thermoplastic and thermosetting plastics by flame test.

Materials required: Pair of Tongs, spirit lamp, samples of plastics (Collect small pieces of plastics from the objects like comb, tooth brush handle, plastic bucket, handle of utensil, electric switch, piece of melamine or meals plate and coffee mug)



Fig-13: Conducting flame test

Procedure:

- Take a spirit lamp and light it.
- Clamp one piece of plastic sample (say piece of tooth brush with tongs)
- Place the sample on spirit lamp flame. See fig. 13. Observe the changes during the burning of sample.
- Note your observations like, whether sample is being softened or burnt with smell or become hard etc.
- Repeat the procedure with other samples.
- Record your observations sample wise in the following table - 3.

Note: While doing this activity, if needed, cover your nose and mouth with a mask to avoid breathing of fumes. And also keep yourself away from spirit lamp flame when you put sample on the flame by stretching

Table-3

Sl.no.	Name of the plastic sample	Softened/burnt with burning smell and become hard	Thermoplastic/ Thermosetting plastic
1.	Tooth brush handle		
2.	Comb		
3.	Piece of bucket		
4.	Handle of utensil		
5.	Electric Switch		
6.	Meals plate		
7.	Coffee mug		

In the above activity, we have taken the known samples and tested. If unknown samples are given, how do you decide whether it is thermoplastic or thermosetting plastic?

If you burn a piece of wood, paper, cloth, steel rod, do you notice similar observations like plastic material? How are they different from plastics?

Based on the observations can you write a note on the properties of thermoplastics and thermosetting plastics?

3.7.1 Thermoplastic

This is a plastic which will soften when heated and harden when cooled. A thermoplastic is a polymer that turns into a liquid when heated and freezes to a glassy state when cooled sufficiently.



Do you know?

Hermann Staudinger (1881-1965) :

Hermann Staudinger, a German Chemist, in 1920 made an important step forward in the processing of synthetic materials when he developed thermoplastics which are stable in themselves. Hermann Staudinger won Nobel Prize in 1953 for demonstrating that **Polymers are long-chain molecules.**



3.7.2 Thermosetting Plastic

Thermosetting plastics are simply plastics, when moulded into a shape and allowed to cool down, will remain in moulded form and will not change their shape. When heated again they will char or burn.

Thermosetting plastics are synthetic materials which gain strength during moulding by heating, but cannot be re-moulded or reheated after their initial heat, moulding. Thermosetting plastics are not re-mouldable. Strong cross links are formed during the initial moulding process that gives the material a stable structure. They are more likely to be used in situations where thermal stability is required. Where do we use this type of plastics?

Observe the kitchenware in your house or visit any home appliances shop. What do you notice? Is all kitchenware totally made up of metal? With what materials are the handles of utensils made? Utensils are made of metals like aluminum, copper or steel. Then what is the additional material?

Bakelite is used for making handles of various utensils due to its poor conductivity of heat and electricity. It is also used for making electrical appliances including switch boards. Bakelite is used as an alternative for pearl and jade stones. You can see the Bakelite made articles in figure 14.



Fig-14: Articles made of Bakelite

The other thermosetting plastic, Melamine used for making kitchenware. Utensils and other items of kitchen are made by melamine. It is also used for making of floor and dress material for their nature of fire resistance. Computer and TV cabinets are made of melamine. *Now List out the melamine products in your house.* You can see few melamine articles in figure15.



Fig-15: Articles of Melamine

3.7.3 Why do we prefer plastics?

Plastics are non- reactive: You might have experienced that iron gates and nails exposed to atmosphere, soon get rusted. But does this happen to plastic articles? Plastic material will not corrode easily. That's why they are used to store various kinds of materials including chemicals.



Do you know?

Father of Plastic Industry

A Belgian scientist named Dr. Leo Hendrik Baekeland was responsible for the invention of Bakelite. In 1907 he was working as chemist, by accident he discovered the compound of carbonic acid and formaldehyde. When he tried to reheat the solidified compound, he discovered. It would not melt-no matter how high the temperature was. Dr. Baekeland is considered as the father of the present plastics industry.

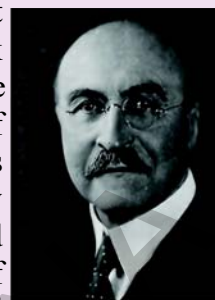

Hot Pin Test

To test if a piece is Bakelite, get a very very hot pin from an open flame source, then touch the pin to the item. If it is Bakelite it will not penetrate. It may give off the acid smell and it may leave a purple burn mark. If the pin penetrates or melts the plastic, then it is not genuine Bakelite.

Plastic is very light, strong, durable and can be moulded into different shapes and sizes. Plastics are generally cheaper than metals

Why do electrical wires have plastic covering? You might have seen pans, pressure cookers and screw driver handles. Why are they made of plastic? Plastics are poor conductors of heat and electricity.



Think and Discuss

- Certain fry pans are said to be non-stick. What made them non-stick?
- Firemen wear dress which does not catch fire. What type of fabric is it made of?

3.7.4 Plastics and environment

You must have seen garbage (waste) dumps. Some articles there seem to remain for a long time while some other disappear. You may notice that most of the material that does not disappear are the polythene bags. Polythene is a plastic. It is mainly used for making carry bags.

The polythene bags thrown around are responsible for clogging drains. Animals in urban areas, particularly cows, eat polythene bags containing food material. Can you imagine the consequences? See the Fig-16 and read the comments of Supreme Court of India about the effect of plastic on environment.



Fig-16: Plastic bags found in the stomach of a cow after a postmortem

With the direction of the Supreme Court of India, very thin polythene bags have been banned to stop indiscriminate usage of polythene bags. What is the difference between the banned polythene bags and the bags using presently in place of previous ones? What do you notice on that bags? Some efforts are taking place to reduce negative consequences of plastics on the environment.

If we burn plastic, it creates a lot of air pollution.

***“Plastic bags are more danger than atom bomb for future generations”:
Supreme Court of India.***

“Excessive use of plastic bags and their unregulated disposal has been choking lakes, ponds and urban sewerage systems, the Supreme Court said while warning that it posed a threat more serious than the atom bomb for the next generation. Andhra Pradesh-based NGOs drawing the court’s attention to 30-60 kg of plastic bags recovered from the stomachs of cows because of irresponsible disposal of plastic bags and defunct municipal waste collection system. But the bench wanted to address the larger questions arising from indiscriminate use of plastic bags, which not only posed a grave threat to nature and environment but also to the human race itself. “All of us are watching how our lakes, ponds and urban sewerage systems are getting choked by plastic bags. Unless we examine a total ban on plastic bags or put in place a system for manufacturers mandating them to collect back all plastic bags, the next generation will be threatened with something more serious than the atom bomb”, Justices Singhvi and Mukhopadhaya said. Large quantities of water packed in plastic pouches, which were thrown around in undisciplined and uncivil manner across the country every day. “A rough estimate shows more than 100 million water pouches are thrown all over the cities and towns in a day” the bench said.

Activity-9

Biodegradable, Non-bio degradable

Let's take peels of fruits and vegetables, left over food stuff, waste paper, cotton cloth and plastic bag. Keep this material in a pit. Open the pit after some days and list the material which remain a long time and those that disappear quickly in the table-4.

Table-4

Type of waste	Approximate time to degrade	Change
Peels of fruits and vegetables		
Left over food stuff		
Waste paper		
Cotton cloth		
Plastic bag		

You observe that certain materials can break down into smaller fragments in the presence of water, sunlight and oxygen. These fragments get further broken down by bacteria. This is called decomposition. A material which is easily decomposed by natural process is called bio-degradable, and one which is not decomposed by natural processes, is called **non-bio degradable**.

The time taken for decomposition depends upon whether a material is bio-degradable or not.

Explore various sources of material including plastic to know the time required for them to decompose.

Plastics take several years to decompose as compared to other materials like peels of fruits, vegetables and waste food stuff which decompose within a short period. Slow decomposition causes environmental pollution. The burning process of synthetic material is also very slow and can't be burnt completely. The process of burning, releases a lot of poisonous fumes into air causing air pollution. So it is better to avoid or minimize the use of plastics.

Make a list of some occasions where you can avoid the plastics and use alternatives.

3.7.5 Reduce, Recycle, Reuse and Recover – 4R principle

Can we avoid using plastics altogether? The entire civilization is enveloped with them. Every walk of life is linked with plastics. Now you can understand that you cannot avoid use of plastics completely but we can reduce, recycle, and reuse plastics and avoid indiscriminate use of plastics. We can also adopt recovery mechanisms to convert waste into a usable resource. Let us discuss the **4R** principle for creating an eco friendly environment.

Reduce

What do you observe when you attend a marriage or function? What plates they use to serve food? What type of glasses for the drinking water is supplied? What containers do they use to serve sweets and ice cream? What are the spoons made up

of? Everything is made of plastic. Imagine how much plastic garbage will be accumulated in this single function. Is there a way to stop this 'Use and throw' culture? Discuss and write the ways and means where we can reduce the usage of plastic, to avoid its negative consequences on environment.

Land filling of plastics and burning of plastics in incinerators is the other way of disposal of plastics. They too have negative consequences. Therefore, we should reduce its usage whenever it is possible.

Reuse

Have you observed that when we go to market to buy something we go without any bag? With the result that we come back with lot of plastic bags. Every time we go to market, we accumulate lot of plastic bags. Some of these can be used again and again. Are we doing so? Articles made of plastics may be used again and again for its optimum utilization. This should be every body's concern for an eco friendly environment. If anything you feel now out of fashion and you want to buy a new one, give it to others instead of putting it idle at home or throwing it out.

Can you give certain instances where we reuse plastics?

Recycle

You might have noticed your mother selling old plastic articles which are broken and not useful, to the local vendor.

What will they do with that? They collect all plastics from the households and send it for recycling. From this recycled plastic new products are prepared, after giving it a proper treatment.

- Are all types of plastics recyclable?

There are 60,000 types of plastics available in the world as on today (the synthetic fibers that we discussed are also plastics). There are only 6 from these 60,000 that we use regularly. We have seen that each of these six plastics is given a code. These codes help us in recycling.

PET (code 1) and HDPE (code -2) are commonly recycled. But LDPE (code -4 used for carrier bags) is not recycled commonly. Similarly PVC (code-3) which is used for pipes are currently not recycled. The PS (code -6), used for making coffee cups, egg boxes, packing peanuts and 'take out' food packing can be recycled. Recycling can be used to obtain materials from which the original products were made.

Recycling code

In activity-7 we raised certain questions regarding recycling symbol code and its use. Now let us discuss them in this section.

The Society of the Plastics Industries, Inc. (SPI) introduced its voluntary resin identification coding system in 1988 to assist recycling programs.

The SPI coding system offered a way to identify and sort the resin content of containers commonly found in the household waste stream. Plastic household containers are marked with a number that indicates the type of resin, or plastic as shown in fig-9.

To identify the plastic, look at the recycling icon, the chasing arrows. Inside the arrows, there will be a number that identifies the polymer. When the number is omitted as seen in the figure 17, the symbol is known as the **Universal Recycling Symbol**, indicating generic recyclable materials.



Fig-17: Universal recycling symbol

What is role of codes in recycling process?

Each plastic is manufactured with different processes. During recycling process, if same codes are not sorted out separately the whole lot meant for recycle will spoil the process. Therefore, it is essential to recycle the same codes in one lot. If you add a simple PET bottle in the lot of other plastics during recycling process, the entire lot will be spoiled. Think why?

Uncoded plastics

Do all plastics have resin identification code on them? Plastic tarps, toys, computer key boards and many other products simply do not fit in the coding system adopted for recycling. Wide variety of plastic materials are made to suit the needs of consumer by using different varieties of plastic resins or mixtures of resins. Is it possible to code thousands of plastic varieties? Recycling of various types of plastics is not commercially viable because their production when compared to coded plastics is less. Code 1 and 2 plastics occupy major share in recycling plastics.

Recover

Supreme Court gave a judgment on ways and means of solid waste management and gave order to implement this in all the cities of India by 2003. In the solid waste garbage of municipalities, plastic occupies major share. The principle of recover plays major role in this solid waste management. The solid waste should be converted into resources such as electricity, heat, compost and fuel through thermal and biological means.

Is any such effort for solid waste management taking place in your village/ town.? How do you appreciate 4R principle?



Key words

Acrylic, synthetic fibre, Bakelite, biodegradable, blend, cellulose, melamine, natural fibres, non-biodegradable, nylon, petro chemicals, plastics, polymer, polyamide, polythene, polyester, rayon, recycling, spinneret, terricot, terylene, terriwool, thermoplastics, thermosetting plastics, universal recycling symbol.

What we have learnt?

- Synthetic fibres are made of very large units called polymers.
- Rayon is an artificial silk made up of cellulose fibre.
- Nylon is made artificially by using raw material like coal, water and air
- Polyester is a synthetic fibre.
- Acrylic is artificial wool made from coal, air, water, oil and limestone.
- Petro chemicals are used to manufacture synthetic fibres.
- Commonly used synthetic fibres are rayon, nylon, polyester and acrylic.
- The different types of fibres differ from one another in their strength, water absorbing capacity, nature of burning, cost, and durability.
- Synthetic fibres and plastics enveloped our life.
- The waste created by plastics is not environment friendly.
- Plastics take years to decompose.
- Enjoy the good qualities of synthetic fibres and plastics and reduce the indiscriminate use of plastics to minimize environmental hazards.
- Synthetic fibres find uses ranging from house hold articles to healthcare.
- Synthetic fibres blend with natural and artificial fibres.



Improve your learning



I. Reflections on concepts

1. Why do some fibres are called Synthetic? Explain. (AS₁)
2. What are thermosetting plastics? Give two examples. (AS₁)
3. Give reasons “for using plastic containers as storing devices.” (AS₁)

II. Application of concepts

1. How do synthetic fibres have changed our daily life? (AS₁)
2. What would happen, if we make electric switches with thermo plastics. (AS₁)
3. What could be the consequences if plastics are not properly disposed? (AS₁)
4. Rani wants to buy clothes to her parents for winter wear. What types of clothes would you suggest? Specify reasons. (AS₁)

III. Higher Order Thinking Questions

1. What made the human beings to search for the alternative for natural fibres? (AS₂)
2. Imagine what would happen if we do not discover plastics? (AS₂)
3. “Indiscriminate usage of plastic is a serious threat to bio diversity.” What are the efforts of Government and Non government organizations in this regard. (AS₂)



Multiple Choice Questions

1. Rayon is prepared by ()
a) Coal b) Oxygen c) Fibre d) Cellulose
2. Necessity of labels on clothes ()
a) Required by law b) To identify fabric content
c) Both A and B d) not decomposable
3. The material which is not decomposed by natural process is called ()
a) Non bio-degradable material b) Bio-degradable material
c) Polyester d) Nylon
4. The symbol  represents ()
a) PET b) HDPE c) LDPE d) Others
5. Which is a Natural fibre among the following? ()
a) Rayon b) Nylon c) Polyester d) Silk



Experiments

1. Conduct a flame test to identify Thermo plastics and Thermosetting plastics and prepare a report.
2. Take a wool, silk, cotton thread, bandage, piece of umbrella cloth, thread of sweater, piece of rope and carefully conduct a flame test. Based on smell and type of melting Classify them as natural and artificial fibres.



Project Works

1. Prepare a table of various synthetic fibres which are used to make household articles from them.
2. Collect the figures made up of thermosetting, thermo plastics used in your daily life and make a poster.
3. Prepare a chart which can explain recycling codes, full names and acronym of plastic and its usage for various household articles, recycled or not, if recycled what will be made from that.

In the previous classes, you have studied about some materials that are used in our daily life. For example you studied about natural fibres. The soil, Acids, Bases, salts and their properties characteristics. You also studied changes around us like rusting etc. In this chapter you learn about the properties of metals and non-metals

You are familiar with a number of metals like aluminium, copper, gold, iron, etc., which are normally solid in state at room temperature. Mercury is an exemption, which is liquid at room temperature.

- Can you name some objects made of metals?

Observe the fig-1. Try to name the metals from which the objects are made. Add names of more metals that you know to the list.



Fig-1

Your first answer is gold. Some of you may also have added aluminium, silver, lead, iron, copper, tin, mercury etc.

- Did any of your friends add steel to the list of metals?
- Do you think that steel is a metal?

Let us learn the properties of metals so that you are able to answer these questions at the end of the chapter. You also learn about another type of materials, called non-metals, which may be new to you.

Now observe carefully all the materials that you have listed above as metals.

- Do all these look alike?
- Do all of them shine?
- Are they hard or soft?
- Do they break easily?
- Can you group materials into two categories by looking at their properties?

We try to find two groups, then discuss and compare them in detail in this chapter.

4.1 Physical Properties



E2PFF1

Before we start this section, you will need to collect pieces of iron (iron nails), copper, zinc, sulphur powder, aluminium, carbon, magnesium and iodine for carrying out the activities.

Appearance

In previous classes, you learnt that the materials which have a bright surface and reflect light are called **lustrous** materials and materials that do not shine are **non-lustrous**.

Activity-1

Observing appearance and colour of some materials

Observe the appearance of your samples. Look at their colour. Decide whether they appear shining or dull and record your observations in table - 1. (If the surface seems dirty, clean it with sand paper.)

Table-1

Sample	Appearance Shining/not shining	Colour
Iron		
Zinc		
Copper		
Sulphur		
Aluminium		
Carbon		
Magnesium		
Iodine		

Your observations in the table shows that some materials are shining and some are dull.

- Which of the samples did not shine even after you cleaned them with sand paper?

Generally metals are lustrous. Do all lustrous materials are metals?

We all know that mirror reflects light.

- Can a mirror be called metal?

No, so you need to look at several properties to decide if a given material is metal or not.

4.1.1 Sonority

While Aryan was carrying a geometry box he slipped and fell down. He noticed that the box made a ringing sound when it hit the hard floor. It was similar to the sound that of ringing bell.

- Have you observed material used to make school bell or bells in temple?
- Why are wooden bells not used in schools?
- Do all materials produce sound when they dropped on hard surface?

Let us find

Activity-2

Listening the sound produced by some material

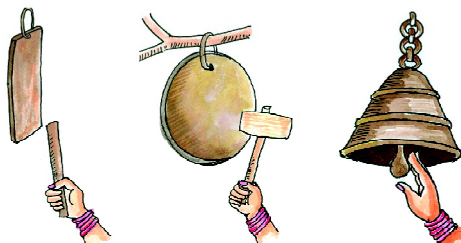

Fig-2

Drop a piece of coal on the floor and listen to the sound.

- Do you think coal is sonorous?

Take the pieces of zinc, copper, aluminium, magnesium and tightly packed packets of sulphur, carbon and iodine. Drop them one by one, on a hard surface. Listen carefully to the sound produced and record your observations in table-2.

Table-2

Material Sample that Produce sound	Material Sample that donot Produce sound

- What similarity do you notice among materials which produce sound?

You may notice that some of the materials produce sound and some of them do not. Materials which produce ringing sound are called sonorous materials. Generally, most of the metals are sonorous. The materials other than metals are not sonorous.

Lustre and **sonority** are the properties associated with the metals. But there is no need that all metals should posses this property. For example, though mercury is a metal, it is not sonorous.

- Which property of metals first attracted the attention of human beings? The story of early tools will give you a hint.

4.1.2 Malleability

Have you ever noticed the thin silver foil used to decorate sweets or the thin aluminium foil used for packing food?

Try to observe a blacksmith at work. He beats a hot iron piece repeatedly till its shape changes.

- Do you bring a similar change in the shape of a clay material by beating it?

Not all materials can be converted into thin sheets to make the desirable objects.

Activity-3

Identifying malleability of material

Take a hammer and beat the material samples which are used in Activity-2 and observe the changes in material samples. Record your observations in the table-3.

Table-3

Observing the change	Name of sample
Flattens	Iron,
Breaks/ converts into powder	
No change	

Story of Early Tools

Do you think tools were always made of metals? Early human beings made their tools from which were easily available - stone and wood. Later, they used the bones of animals.

Then they discovered metals like copper and iron. Tools made of copper and iron are much stronger than tools made of stone and wood. Metals had the advantage of not just being harder but they can be heated in a fire and moulded or cast into different shapes. So it became possible to make a wider range of tools with such metals.

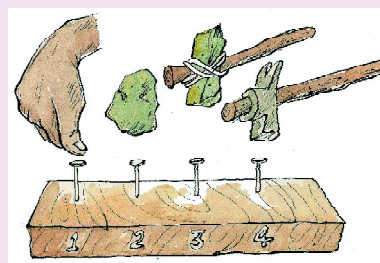

Fig-3 : tools are made of different materials

Some of the samples, when beaten hard, were flattened whereas some materials broke into pieces or became a powder.

The materials which can be flattened into thin sheets are called **malleable materials**. Malleability is one of the properties associated with metals.



Fig-4

What did you observe in the case of iron? You may not be able to flatten it but the blacksmith can do it. He heats it before beating. So we can say that materials differ in the range of their malleability.

Metals like aluminium, silver and gold are highly malleable.

4.1.3 Ductility

We use wires in different situations in our daily life. Look at the samples given in the table-4.

Table-4

Sample	Can we convert it into Wires (Yes/No)
Iron	yes
Zinc	
Copper	
Sulphur	
Aluminium	
Carbon	
Magnesium	
Iodine	

- Have you ever seen the wires made up of materials mentioned in table-4.

Write yes, if you have seen wires made of them.

Take help from your teacher, friends and elders to decide which of the material can be used to make wires.

From the table-4 you may infer that some materials can be drawn into wires and some materials cannot be drawn into wires.



Fig-5

The property of drawing a material to make fine wires is called **ductility**. Most metals are ductile.

We use connecting wires made up of metals in Electric Circuits.

- Is ductility the only property of metal to use them as connecting wires in electric circuits?

Let us explore another property of metals.

4.1.4 Electrical Conductivity

You might have seen an electrician using the screwdriver.

- What materials does it contain?
- Why does not a screwdriver used by electricians have metal handle?

Activity-4

Identifying electric conductivity of a material

Arrange an electric circuit with a battery and bulb (remember the simple electric circuits from 7th class). Close the circuit using an iron nail, as shown in figure 6.

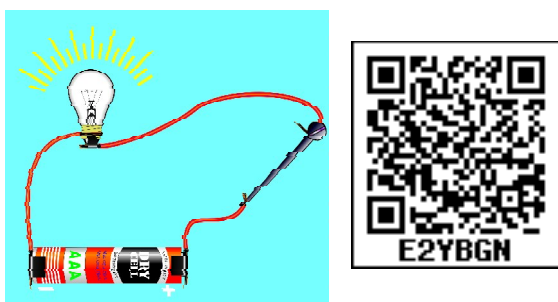

Fig-6

Observe whether the bulb glows or not. Repeat the same experiment using the other samples and record your observations in the table-5.

Table-5

Sample	Does the bulb glow? (Yes/No)
Iron	
Zinc	
Copper	
Sulphur	
Aluminium	
Carbon	
Magnesium	
Iodine	

- Do all the samples allow the bulb to glow?

Materials that allow electricity to pass through them and make the bulb to glow are called **electric conductors**. Most metals like iron, copper and aluminium are good conductors of electricity.

Talk to an electrician. Look at the handles of his tools.

- Are the handles made of the same material? If not, why?

Note the precautions to be taken while working with such tools.

The handles of both electrical appliances and cooking utensils are not made of metals. Because electrical appliances conduct electricity.

- What do cooking appliances conduct?



Think and discuss

How will you close the circuit using sulphur, carbon or iodine? They may be in powder form. Try to tightly pack the powder in a straw and use it. Think of other ways!

Activity-5

Observing heat conduction by metals

Take an iron rod. Stick pins on it with the help of wax (see fig-7). Now fix the rod to a stand. Heat one end of the rod with a spirit lamp and see how the pins fall off?

- Why did the pins fall from iron rod?
- Pin of which end fell first?
- What could be the reason for this?

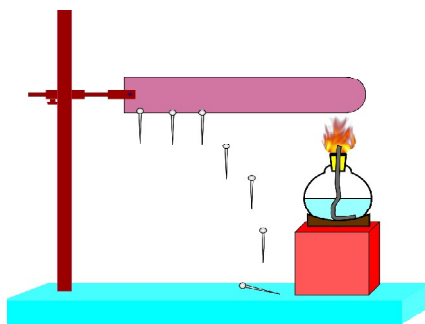

Fig-7

You know that the pin fell because of the heat supplied to the iron rod makes the wax to melt at one end. The wax closer to the flame melted first. This activity clearly shows that heat moves from one end of the iron rod to the other. This property of a material is known as **conductivity of heat**. All metals conduct heat. But all metals do not have equal conductivity. Iron, copper and aluminium cooking vessels are preferred due to their high conductivity of heat.

Do it!

On the basis of all the activities carried out, fill in the table - 6.

We find that it is the metal which possess most of the properties of lustre, malleability, ductility, sonority, conduction

of heat and electricity. Non-metals generally do not show these properties.

The properties you have studied so far are all physical properties. Though these properties are quite reliable, chemical properties are better indicators of determining as to whether a given material is metallic or not.

4.2 Chemical properties of metals

Let us try to see what happens when metals and non-metals react with other substances.

4.2.1 Reaction with Oxygen



Lab Activity

Aim: To know the reaction of oxygen with metals and non-metals

Material required: One metal sample (magnesium)

and one non-metal sample (sulphur), spirit lamp or Bunsen burner and litmus papers, petridishes, deflagrating spoon, glass jar etc.



Table-6

Material sample	Lustrous	Sonorous	Conducts heat	Conducts electricity	Malleable	Ductile
Iron						
Zinc						
Copper						
Sulphur						
Aluminium						
Carbon						
Magnesium						
Iodine						

Procedure:

- Take a small strip of magnesium and note its appearance. Burn it. Note the appearance after burning.
- Collect the ashes of magnesium in a petridish and add some distilled water to it. Test the solution with red and blue litmus papers. Note the colour change in table-7.
- Take a small quantity of powdered sulphur in a deflagrating spoon and heat it on a spirit lamp. (You can make your own spoon using a metal bottle cap and wrapping a wire around it).

(Caution: *Do not inhale fumes, they are harmful*).

- As soon as sulphur starts burning, introduce the spoon into a glass jar/ tumbler. Cover the tumbler with a lid to ensure that the gas produced does not escape. Remove the spoon after some time but try to keep the jar covered. Add a small quantity of water into the tumbler and quickly replace the lid. Shake the tumbler well. Check the solution with red and blue litmus papers. Record the changes in table7.

Table-7

Sample	Physical Appearance before Reaction	Physical Appearance After Reaction	Effect on Litmus Paper
Magnesium			
Sulphur			



Fig-8

- What do you observe?

When the samples are burnt, they react with oxygen in air to give different products. See how.

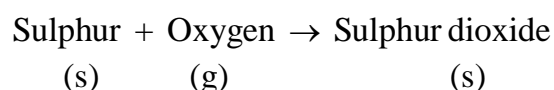
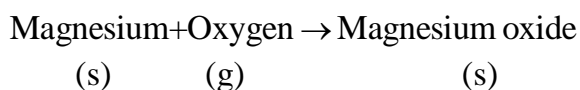

All the products in the above reactions are oxides, but are they same in nature? The oxide of magnesium turns red litmus to blue.

The oxide of sulphur turns blue litmus to red. From this knowledge, you can say that magnesium oxide is basic and Sulphur dioxide is acidic.

You can also infer that non-metals react with oxygen to give oxides which are acidic, while metals react with oxygen to give oxides that are basic in nature.



Think and discuss

Is our body a metal or non-metal?

Most of the human body is made up of water (H_2O). It isn't surprising that majority of a human body's mass is oxygen. Carbon, the basic unit of organic molecules is the second. 99% of the mass of the human body is made up of just six elements. Oxygen (65%), carbon(18%), hydrogen (10%), Nitrogen (3%), calcium (1.5%), phosphorus (1.0%). Can we decide whether our body is metal or non metal?

4.2.2 Rusting of Metals

In class VII we studied rusting of iron in detail. Recall that iron rusts when it is in contact with air that contains oxygen and moisture. When it is covered with paint, it cannot come in contact with air, hence it does not rust. If paint is gone on iron then the rust forms on it.

Something similar happens with other metals also. Magnesium ribbon is dull when exposed to air and shiny if we cut it.

Silver objects and jewellery becomes

Metals and Non-Metals

black. Copper statues and vessels become dull green. All these metals react with components in air. But gold jewellery does not become dull.

- What could be the reason for gold does not become dull?

Different metals react with the components of air in a different manner at different rates and conditions. There are some metals which do not react with the components of air. Gold and platinum are such metals which do not rust.

Activity-6

4.2.3 Reaction with water

(**Note:-** This is a demonstration to be carried out by the teacher. Sodium is extremely reactive and dangerous, so students should see the demonstration from a distance.)

Take a 500 ml beaker or a big glass trough and fill half of it with water. Take the sodium which is stored in kerosene and keep it on a sheet of filter paper to blot the kerosene and cut a very small piece of sodium from it. Put the remaining sodium back in kerosene.

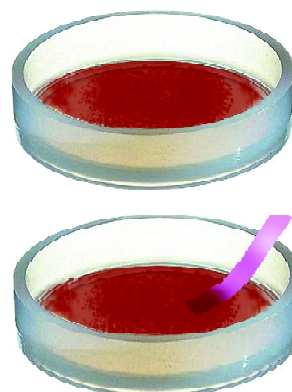

Fig-9

Standing away from the trough put the sodium piece in water using forceps. The piece of sodium floats on the surface of the water with a 'hissing' sound. This shows that sodium is reacting extremely fast with water. After the reaction is complete, test the solution with litmus paper.

Repeat the same experiment using aluminium or iron. You will not see any change even after five minutes. This is because these metals react extremely slowly with water.

- Does non-metals react with water?

Generally they do not react with water, (except chlorine and fluorine.)

4.2.4 Reaction with Acids

Activity-7

Table-8

Sample	Reaction with dilute hydrochloric acid	Reaction with dilute sulphuric acid
Iron		
Zinc		
Copper		
Sulphur		
Aluminium		
Carbon		
Magnesium		
Iodine		

Take the samples given in the table 8 in separate test tubes. Add 5ml of dilute hydrochloric acid to each of the test tubes with the help of a dropper.

Observe the reactions. If you find no reaction, heat the test tube gently. If you still see no reaction, add 5 drops of conc. Hydrochloric acid. Now bring a burning Match stick near the mouth of the test tube and observe what happens. Record your observations in the table-8.



Fig:10

- Do you find any difference in these reactions?
- When do you notice a pop sound with a burning match stick?

This sound indicates the presence of hydrogen.

You found that some metals react with dilute hydrochloric acid liberating hydrogen but non-metals usually do not react with acids.

Repeat the same experiment with sulphuric acid and record your observations in table-8.

4.2.5 Reactivity of metals

Activity-8

You have already seen that some metals react with air and others do not. The reaction is fast in some cases like magnesium and slow in case of silver and copper. Similarly, different metals react with water and acids under different conditions. Let us explore this reactivity further.

Take six beakers and label them a, b, c, d, e and f. Take 50ml of water in each beaker prepare Copper Sulphate solution in beakers 'a', 'b', prepare Zinc Sulphate solution in beakers 'c', 'd' and prepare Iron Sulphate solution in beakers 'e', 'f'.

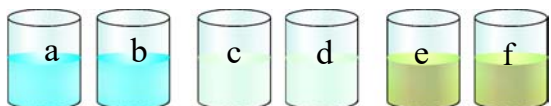

Fig:11

Now put:

- * Zinc granules in beakers 'a', 'e'
- * Iron nails in beakers 'b', 'd'
- * Copper turnings in beakers 'c', 'f'

Leave the beakers undisturbed, for some time. Record the changes in the colour of the solutions in the table-9.

Table-9

Solutions	Observations
Beaker 'a'	
Beaker 'b'	
Beaker 'c'	
Beaker 'd'	
Beaker 'e'	
Beaker 'f'	

The blue colour of copper sulphate disappears and a red mass of copper deposits at the bottom of the beaker 'a'.

Also notice that in beaker 'b' red copper deposits on the iron nail leaving light green iron sulphate solution.

- What could be the reasons behind these changes?

In beaker 'a' zinc displaces copper from copper sulphate giving rise to colourless

zinc sulphate solution. Iron displaces copper from copper sulphate in beaker 'b' leaving light green colour of Iron sulphate. Zinc displaces iron from iron sulphate in beaker 'e'.

Copper sulphate+Zinc → Zinc sulphate+ Copper

Copper sulphate+ Iron → Iron sulphate+ Copper

Iron sulphate+Zinc → Zinc sulphate+ Iron

Similar to the reactions in beakers 'a' and 'b', is there displacement of zinc from Zinc sulphate by Copper in beaker 'c' and Zinc from Zinc sulphate by Iron in beaker 'd' and iron from iron sulphate by copper in 'f'?

- Do you find any changes in beakers c, d and f?

Since we do not see any change in the other three beakers (c, d and f) we can infer that.

- i) Copper is unable to displace zinc from zinc sulphate. (beaker-c)
- ii) Copper is unable to displace iron from iron sulphate. (beaker-f)
- iii) Iron is unable to displace zinc from zinc sulphate. (beaker-d)

We can understand with the above reactions that zinc is the most reactive metal and can replace a less reactive metal, copper or iron from its solution, but a least reactive copper cannot replace the more reactive metals iron, zinc from the solution. Similarly less reactive iron cannot displace zinc from zinc sulphate solution.

Reactivity order is

zinc > iron > copper.

4.3 Some uses of non-metals



You are all aware of the uses of metals. Non-metals are also useful. The three non-metals studied by us are sulphur, carbon and iodine.

Let us know about their uses.

Sulphur is used in making fireworks, crackers, gun powder, matchsticks and antiseptic ointments. It is found in onions, garlic, eggs, hair and nails.

Activated carbon is used as a decolourising agent and also in water purification systems.

Iodine mixed with alcohol is used in medical purposes.

Uses of metals

Have you ever noticed a thin silver foil decorated on sweets and thin aluminium foil

used in inner packing of food materials and toffees?

Aluminium and copper mixture is used in currency coins, medals and statues. Zinc and iron mixture is used in making of iron sheet. Most of the agricultural instruments are made by iron. Electrical appliances, automobiles, satellites, aeroplanes, cooking utensils, machinery, decorative materials made by metals due to their malleability, ductility.

Try this

Recall the names of the some of the laboratory acids and bases that you know. Write down their names in table -10 and identify metal/non-metal present in them, which form oxides when react with oxygen. Take the help of your teacher table -10.

Have you seen a periodic table?

Try to find the metals and non-metals that you come across in the periodic table.

Table-10

S.No.	Name of the Base	Metal present in it	Name of the Acid	Non- Metal present in it
1.	Calcium hydroxide	Calcium	Sulphuric acid	Sulphur



Key words

Metals, non-metals, lustrous, sonority, malleability, ductility, good conductors of heat and electricity, oxides of metals and non-metals, displacement reaction.

What we have learnt?

- The materials which show brightness on surface and reflect the light are called lustrous and which do not shine are non-lustrous material.
- The property of materials by which they can be beaten into thin sheets is called malleability.
- The property of drawing material to make fine wires is called ductility.
- The ability of materials to produce a particular sound when it is dropped on the hard surface is termed as sonorous.
- Metals often possess all the properties like are lustrous, sonorous, hard, malleable, ductile, good conductors of heat and electricity Ex: copper, magnesium, aluminium, iron, zinc etc.
- Some metals react with the components of air in different manner with different rates and in different conditions.
- Gold and platinum are the metals which do not react with air.
- Some Metals react with acids and liberate hydrogen gas.
- Metals can displace each other according to their reactivity.
- Oxides of non-metals are usually acidic in nature and Oxides of metals are usually basic in nature.



Improve your learning



I. Reflections on concepts

1. Explain about ductility. (AS₁)
2. Explain the physical properties of metals with suitable examples. (AS₁)
3. Draw the diagram of identifying electric conductivity of a material. (AS₃)

II. Application of concepts

1. If you are given two samples, how do you distinguish which one is metal and which is non metal? (AS₁)
2. Which metals are used in making jewellery? Why? (AS)
3. Why don't cooking pans have metal handles? (AS)

III. Higher Order Thinking Questions

1. Dumping of waste material made up of metals and non metals leads to environment pollution. Do you support the statement? Give your justification with suitable examples. (AS₇)
2. In a chemical reaction iron is unable to displace zinc from zinc Sulphate. Why? (AS₁)
3. How the property malleability of metals is used in our daily life? (AS₇)



Multiple Choice Questions

1. Sulphur dioxide, by nature is ()
 - a) Basic oxide
 - b) Acidic Oxide
 - c) Neutral Oxide
 - d) Dual Nature oxide
2. Maximum metals are obtained in the state of ()
 - a) Liquid
 - b) Solid
 - c) Gaseous
 - d) Plasma
3. Some metals react with acids and evolve ()
 - a) Hydrogen
 - b) Oxygen
 - c) Carbon dioxide
 - d) Nitrogen
4. Generally non metallic oxides are by nature ()
 - a) Basic
 - b) Acidic
 - c) Neutral
 - d) Dual



Experiments

1. Conduct an experiment to know the reaction of Oxygen with metals and non metals.
2. The nature of oxides helps to identify the metals and non metals. Conduct an experiment to prove this and record the observations.
3. Identify the electric conductivity of materials with an experiment.



Project Works

1. Collect the information about metals which we use in our daily life, and their uses. Write a report on it.
2. Imagine the human life without metals. Write a report.

Throughout the day we are constantly exposed to different sounds. For example, people talk, birds chirping, cries of animals, sounds of autos, motorbikes, buses, lorries, tractors, trains and music from loudspeakers at public places, television. Sound is an unavoidable and integral part of our lives. We are always surrounded by sound. It is almost omnipresent. Sound plays an important role in our lives. It helps us to easily communicate with each other.

Make a list of sounds that you get to hear in your surroundings.

- How are these sounds produced?
- How do sounds travel from one place to another?
- Are we able to hear all sounds in nature?

We will try to seek answers to some of these and similar questions in this chapter.

5.1 Production of sound

Activity-1

Listening to sound and predicting its source

Let us sit quietly for a while and listen to



sounds of objects, animals. Prepare a list of sounds that we hear and the sources from which they might have originated. Write them in table-1.

Table 1

Sound heard	Source of Sound
Feeble barking	Dog from some distance
Bell ringing	

Activity-2

Identifying different sounds

Make a student to stand at the black board such that his face is turned towards the black board (other student will see back of that student). Ask other student in the class to make different sounds. The student at the board should tabulate the sounds he heard and sources of those sounds as shown in table-2.

Table 2

S.No.	Sound heard	way of producing Sound
1.	Gala Gala	A few stones rattling in a metal box
2.	Eela (whistling sound)	A student has produced the sound from her/his mouth
3		Some one striking the table tab with a scale
4		Someone thumping the ground with shoes
5		
6		

- How does the student at the black board guess the source of sound without actually seeing the source?

You might have observed many other sources of sound in your daily life. Try to listen and identify some more sources of sound and prepare a list.

- How do objects produce sound?
- What happens when objects made of metals are hit by a hammer or fall down from a height on a concrete floor?
- How does a flute or a whistle produce sound?
- What would you feel if you touch a body while it is producing sound?

Activity-3

Vibrating body produces sound

Take a brass bell (bell used in pooja room or in your school). Ring the bell and listen to the sound carefully. Now hold the bell tightly with your hand as shown in fig--1 and ring it again.

- Do you hear sound from the bell?
- Is there any change in the sound produced in the two situations?

How do you feel when you touch the ringing bell? Remove your hand and ring it again. Do you hear a different sound? Why?



Fig-1: Observing vibrations of bell when it is producing sound

Let us do following activities

1. Fix a rubber band tightly on an empty matchbox as shown in fig-2. Pluck the rubber band and keep it close to your ear.



Fig-2: Listening to sound from match box tied with rubber band

- Do you hear any sound?
- Do you feel any vibration in your hands?

2. Blow air into papers of your notebook as shown in fig-3. What happens? Does the action produce any sound? Do you find any vibrations in the note book?



Fig-3: Blowing air into papers

3. Fill a plate with water and let the water settle. Strike the rim of the plate with a spoon as shown in fig-4. What do you observe? What do you hear? Where do you find vibrations in this case?



Fig-4: Striking the rim of a plate with a spoon

4. Put a hack-saw blade in between a table and a brick as shown in the figure-5 and press it and leave it abruptly. What happens? Does it produce sound? What is the state of the hack-saw blade while it is producing sound?

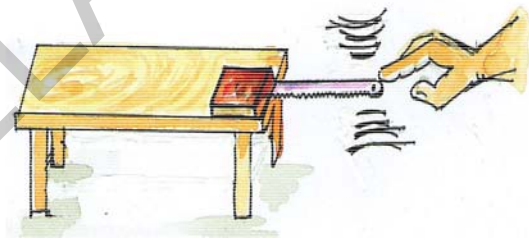

Fig-5: Sound produced by a vibrating hack-saw blade

- What you have observed while doing the above activities?
- What changes took place in those objects?

You must have noticed that objects vibrate while they are producing sound. You can feel these vibrations if you touch the objects. We are able to observe the vibrations of the plate and papers of the book. We have also observed vibrations of the hack-saw blade. Thus, we can conclude that a vibrating body produces sound.

But there are certain instruments which produce sound though we cannot see any vibrations in the instruments like in flute and clarinet etc.

- How do they produce sound?
- Is it possible to produce sound without vibrations?
- Does every vibrating body produce sound?
- Does sound have energy? Let us find out!

Activity-4

Sound has energy



Take a plastic bottle and a cell phone. Cut the top of the bottle so that it looks like a glass. Play songs on the mobile phone in high volume and place it in the bottle. Close the mouth of bottle with a balloon using rubber band so that it covers the bottle as shown in the fig-6 and stretch it tightly so as to behave like a diaphragm. Place some sugar crystals or small size of sand particles on the balloon diaphragm and observe the movement of particles. Do the same activity after removing the phone from the bottle. What do you notice?



Fig-6: Sound has energy

When there is no cell phone inside the bottle, sand particles on the diaphragm remain stationary. While the cell phone plays songs inside the bottle, the diaphragm vibrates which can be seen through dancing of sand particles. The sound produced by cell phone inside the bottle is responsible for these vibrations. Thus, sound has energy to make sand particles vibrate on the diaphragm.

5.2 Musical instruments

You might have observed many musical instruments like Tabala, Flute, Harmonium and Gitar. The sounds produced by these instruments are distinct. It is easy for us to identify sounds separately from different instruments.



- How do they produce sound?
- Why is there a difference between the sounds produced by various musical instruments?
- Which part of these instruments is responsible for production of sound?



Fig-7

Let us do

List out the names of musical instruments and mention the vibrating part of each instrument, write them in table-3.

Table 3

Name of instrument	Vibrating part of it
Tabala	Membrane, air inside hollow body

Have you named all the vibrating parts for each musical instrument? For example, in tabala, not only the stretched membrane but the air inside the hollow body also vibrates.

- Can you name the instrument for which more than one part is responsible for the production of sound?
- How do you compare the production of sound in a flute and sound produced in a water tap when it is turned on, just before the water flows out of it?

Activity-5

Producing a sound that resembles sound of rainfall

We can create the sound of rain by using our fingers.

Start clapping with fore finger on left hand palm, add the middle finger and clap again, then ring finger and lastly small finger successively and reverse the process gradually. If all the students in your class do it simultaneously the sounds produced would resemble the onset and stopping of rainfall.

Activity-6

Observing the changes in sound

Take 4 or 5 metal glass bowls or tumblers of same size. Fill them with different amount of water. Arrange them in the order of decreasing water levels. Strike gently each bowl or tumbler with a spoon. What do you hear? (This is a jalatarang) (see figure-8)

Fill the bowls or tumblers with equal amounts of water, strike each bowl like in above case and listen to the sound.

- What difference do you notice in the sound produced?
- Why is there a variation in the sound produced due to change in the water level of a bowl?



Fig-8 : Jalatarang

Thus we conclude that sounds are produced by vibrating bodies and the air that passes through orifices of the instruments.



Do you know?

Bismillah Khan, the most outstanding and world-famous shehnai player, had attained astonishing mastery over the instrument. He was born in a small village in Bihar about 80 years ago. He spent his childhood in the holy city of Varanasi, on the banks of the Ganga, where his uncle was the official shehnai player in the famous Kasi Viswanath temple.



Bismilla Khan



Chitti babu

Chitti Babu (October 13, 1936 - February 9, 1996) was a renowned classical musician from India, and arguably one of the greatest Veena artists, in the field of Karnatic Music a speciality of South India. He became a legend in his own lifetime. His name was synonymous with the musical instrument Veena, and he was and still is known in the Karnatic Music world, simply as Veena Chitti Babu.

5.3 Sounds produced by human beings

We know that all animals produce sound to communicate with other animals. Human beings use these sounds more effectively. Sounds produced in particular order and manner constitutes our speech. This order in production of sound is different for different languages or communication processes.



Honeybee makes sounds on seeing flowers to communicate to the other bees who are at a distance.

- Do they produce this peculiar sound through their mouth or some other organ used for that purpose?

Majority of communication in human beings is through speech. Which organs do give human beings the ability to talk?

Try this :

Imitate different sounds made by animals. Try to mimic your friends. While making these sounds, place your fingers on your throat. What do you feel? Do your fingers sense any vibrations? Are the vibrations same for all the sounds that you make?

5.3.1 Structure of larynx or voice box

Larynx is the important organ in human body to produce sound.

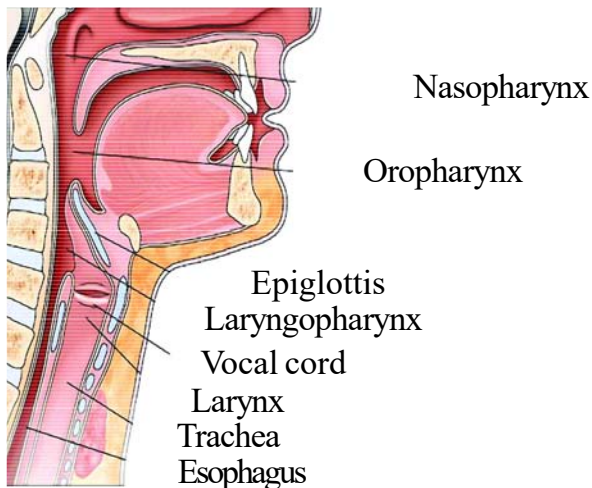

Fig-9: Anatomy of the larynx

Larynx has two muscular ligaments called vocal cords. They are stretched across voice box; it leads to a narrow slit between them, to allow passage of air, to produce sounds.

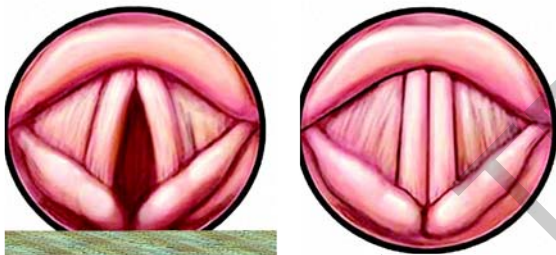

Fig- 10 (a) : Opened vocal cords

Fig - 10 (b) : Closed vocal cords

Observe Fig- 10(a), Vocal cords open during breathing to allow air into lungs.

Observe Fig- 10(b), Vocal cords close when we speak. The air from the lungs presses between them to cause vibration and produce sound.



Do you know?

Length of vocal cords in men is nearly 20mm, in women it is about 5mm less, whereas in children it is shorter. Can we say that the length of vocal cords plays any role in deciding the quality of sound produced by men, women and children?

Activity-7

Observing the movements of vocal cords during speech

Ask a friend to raise his head up. Stretch a chocolate wrapper across his mouth and ask him to blow air on the wrapper forcibly. Observe the changes in movement at his throat. Ask him to blow again slowly and observe the difference in movements.

- What changes do you observe in the movements at the throat on the two occasions?

During the first trial the voice box gets tensed and produces high sound while during the second trial it is close to normal position of throat and produces lower sound. The sound produced in the above activity is due to a combination of vibrations produced in the wrapper and the vocal cord.

If the sound is a kind of vibration, how does this vibration reach us from the source? How are we able to hear the sounds produced at a distance?

5.4 Propagation of sound

5.4.1 Sound needs a medium to propagate

The sound produced by the school bell will be heard by all of us irrespective of whether we are in a room opposite to the bell or in a room at the back of the bell. Obviously, the sound produced by the school bell travels in all directions and reaches us, propagating through the air present between source of the sound and our ears. That is the air surrounding us acts as a medium which allows the sound to pass through it.



Do you know?

Can we talk without moving of lips?

Ventriloquists make sounds or talk with hardly any movement of lips. Lips are slightly separated. The various words are spoken quickly and it is difficult for listeners to notice the difference. They have a very good control over breathing and movement of lips, throat and the muscles of mouth which aids in pronunciation and delivery of speech without much movement of lips and throat. They let the breath out of the mouth by vibrating their lips in accordance to the air supply and relax muscles while doing this. This is one of the most effective vocal activities. In Telangana, Chinchapattana Gomatham Srinivas from Warangal district is a famous ventriloquist. He has performed more than 6000 shows around the world. He created a sensational world record by performing a 32 hour non-stop mimicry show in 1990.



Gomatham Srinivas



Nerella Venumadhav

Mimicry

The mimicry artists maintain a very good control over their voices. The magic they create is solely with their voice. They exercise their vocal parts to keep them fit to be able to enthrall the audience through their voice. Dr.Nerella Venu Madhav is a world famous mimicry artist. He belongs to Warangal District of Telangana State. Govt of India honoured him with Padma Shree in 2001.

Try these yourself and you can acquire a hobby.

- Does sound travel only in air?
- Does it travel in any other gaseous medium?
- Does sound also travel in other media like solids and liquids?

Propagation of sound in different media

Let us try to know how vibration can propagate through different media!

Activity-8

Observing sound propagation in solids

- 1) Strike one end of the table with a pen and ask your friend to listen to the sound produced keeping her ear touching the table at other end and also ask her to listen to the sound by lifting her head slightly from the table as shown in fig-11. Ask your friend what difference she noticed while hearing the sounds when her ears were away from the table and touching the table.



Fig-11: Propagation of sound in solids

- 2) Take a metal or wooden strip. Strike it at one end and ask your friend to hear the sound by keeping his ears at the other end of the strip. Ask your friend what difference he noticed while hearing the sounds when his ears are away from the strip and touching the strip (fig-12).



Fig-12

- 3) Do you know how to make a toy telephone using tea cups?

Take two paper-cups. Make small holes at the bottom of these cups. The holes should be very small so that only a thin string can pass through them. Take a long string. Make sure that the string does not have any knots in it. Push the string through the hole in one of the cups. Fix the string by putting a knot at the end. Similarly fix the string to the other cup. Our phone is ready.

You and your friend can communicate with this phone now. Stand away from each other so that the string is tightly held. One of you can speak in the cup while the other can listen by putting the cup on his ear.



Fig-13

- Are you able to hear the sound?
- What is a medium between you and your friend which is responsible for propagation of sound?

In the above activities you observed that sound travels in solid medium like wood, metal, thread, etc.

- Does sound travel in liquids?
- Can we hear the sound produced in water?

Let us find out.

Activity-9

Propagation of sound through liquids



Fig-14

Take two stones and strike them against each other and listen the sound. Now take a bucket fill it with water. Take two stones and strike them against each other keeping your hands inside the water. Ask your friend

to listen to the sound by keeping his / her ears touching walls of the bucket. Ask your friend about the difference between sounds produced by striking the stones against each other in water and striking them in air.

Thus the conclusion is that sound propagates through matter in all the three states – solid, liquid and gas.



Think and Discuss

What is the effect of humidity on quality of sound propagation? Is there any difference in propagation of sound in air during the summer and winter seasons? Discuss with your friends.

Activity-10

Does sound travel if there is no medium?

Take a glass or plastic tumbler. Make sure that the tumbler is dry. It should be long enough to accommodate a cell phone vertically. Place a cell phone in the glass and play the ring tone of the mobile. Listen to the ringtone and it's volume level. Cover the glass with a small plate and again listen to the ringtone and note the difference in volume of the sound. Now suck the air from the glass keeping it close to your mouth as shown in the figure 15. If you suck air quickly the rim of the glass will stick around your mouth due to air lock. Listen to the volume of the ringtone at this stage. And also ask your friend to listen to the sound for comparing variation in its volume. Is there any change in the volume of sound observed by you or your friend?



Fig-15: Sound does not travel (propagate) through vacuum

When the tumbler is covered with a plate, the volume reduces but you can hear the ringtone. As you start sucking more and more air, you can notice that the volume decreases gradually. If the air is sucked completely, you will not hear the sound at all. But practically it is not so easy. This activity gives an idea about the need of a medium for propagation of sound.

We can demonstrate that sound does not propagate through vacuum and it requires a medium, if we use perfect vacuum pumps to create vacuum

How do we hear sound?

We hear the sound produced in our surroundings with the help of our ears. The structure of ears play an important role in hearing the sound. Let us peep into our ear and try to understand how we hear sound.



5.5 Structure and functioning of the eardrum

Our ear consists of three sections, the outer ear, the middle ear and the inner ear as shown in the figure-16.

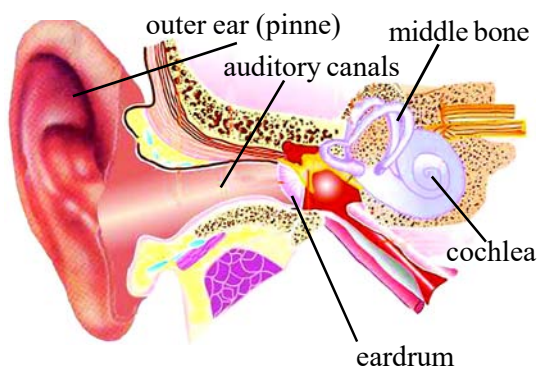

Fig-16: Structure of the ear drum

Pinna of external ear collects the sound vibrations. They enter into the ear canal. We have learnt that sound travels in the form of vibrations. These vibrations strike the tympanum (ear-drum) and make it to vibrate.

The vibrations from the tympanic membrane reach the middle ear (ear ossicles), contains three small bones malleus (hammer shaped), incus (anvil shaped) and stapes (stirrup shaped). They magnify the sound vibrations. The stapes transmits the vibrations to the membrane of oval window. The oval window has the surface area $\frac{1}{20}$ th of the eardrum. By this the vibrations increase 30 to 60 times. The vibrations from the oval window transmit to the cochlea which is the inner part of the ear. The cochlea is filled with thick fluids which transmits the vibrations. The motion of the vibrations in the cochlea is detected by tiny hairs connected to nerves at this point. The vibrations are transformed into electrical signals and carried by the nerves to the brain where the sensation of the sound is realized. The sound vibrations can also reach the inner ear by travelling directly through the bones of the skull, as you tap your head.

Are there any harmful sounds that we hear? What happens when we hear such sounds?

5.6 Characteristics of sound



We learnt how sound is produced and what a vibration is. Now, let us look at different characteristics of sound.

Loudness, feebleness and amplitude

Sometimes people talk loudly and sometimes softly. If we hit a table hard we get a loud sound. If we tap the same table gently, we hear a feeble sound.

In our daily life we hear many loud sounds and feeble sounds on different occasions. For example, sounds emanating from drums during the prayer of assembly in the school are very loud. But the sound produced while we are taking pledge in the assembly is a feeble sound. We know that diwali is a festival of sound and light. When fire crackers they make loud sounds.

- Why are some sounds loud, and some sounds feeble?
- Is there any relation between the intensity of sound and vibrations of the body which produces sound?



Think and Discuss

- "Vibrations produce sound and sound produces vibrations". Which is true in this? Discuss.
- "Our ear has the three media through which sound propagates." Discuss with your friends as to whether the above statement is true.



Lab Activity -1

Aim: To know the relation between the intensity of sound produced by a body and the vibrations of the body.

Material required: Wooden table, 30 cm metal scale or nearly 30 cm hack-saw blade and a brick.

Procedure :

1. Place the blade/scale on the table, with 10cm of the blade on the surface of the table and rest of it in air. Keep a heavy brick on one end of the 10 cm blade/scale kept on table (fig-17).

2. Vibrate the blade gently and observe the vibrations and simultaneously listen to the sounds. Repeat the same for 2-3 times and record your observations in the table-4.

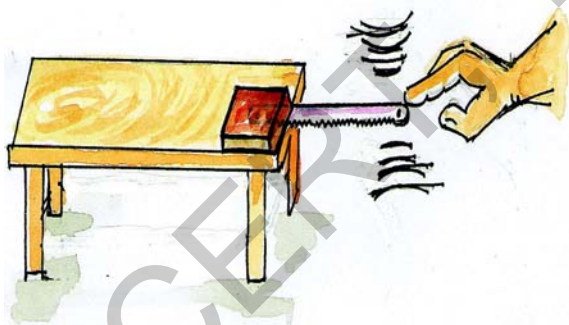

Fig-17: vibrations of the body and intensity of sound.

3. Vibrate the blade using greater force. Observe the vibrations and listen to the sound. Repeat this for 2-3 times and record your observations in the table-4.

Table 4

Force	Vibrations of the blade / scale	Intensity of sound
Small		
Large		

- When do you hear a loud sound?
- When do you hear a feeble sound?
- What difference do you notice in vibrations of blade / scale during loud and feeble sounds?

The initial position of the scale at rest along the surface of the table, is called mean position.

As shown in the figure 18(scale) OA is the mean position of the vibrating body. OB and OC are the vibrations occurring in the body.

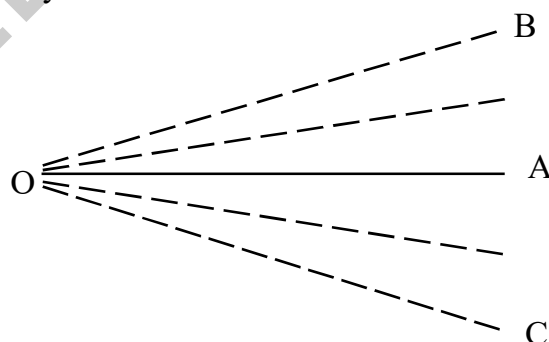

Fig-18

The to and fro motion of a body from its mean position is known as **one vibration**.

The body vibrates from the mean position OA to OC and comes back to OA and then moves from OA to OB and comes back. The maximum displacement of vibrating body from its mean position is called **amplitude**. In the figure-18 given above the maximum displacement is A to

- What difference do you find in the amplitude of vibration for a feeble and a loud sound in the above experiment?



Do you Know?

Decibel is the unit for measuring the intensity of sound. It is denoted as dB.

The unit expressed as decibel in the name of Alexander Graham Bell (1847 – 1942), whose research in sound is famous.

The smallest audible sound (nearer to total silence) is 0 dB. A sound 10 times more powerful than this is 10 dB. A sound 100 times more powerful than that of total silence is 20 dB. A sound 1,000 times more powerful than the sound nearer to total silence is 30 dB. Some common sounds and their decibel ratings are given below.

- Near total silence 0 dB
- A whisper 15 dB
- Normal conversation 60 dB
- A lawnmower 90 dB
- A car horn 110 dB
- A jet engine 120 dB
- A gunshot or firecracker 140 dB

From the above data, compute the following.

1. How many times is a car horn more powerful than normal conversation?
2. How many times is a jet engine more powerful than a whispering sound?



Lab Activity-2

Aim: Identifying pitch or shrillness of a sound.

Material required: A wooden table, two hack-saw blades or metal scales of 30cm length and a brick.

Procedure:

1. Place the first blade/scale on the table, with 10cm portion of the blade on the table and rest of it in air. Keep a brick as weight on the 10 cm portion of the blade/scale kept on the table.
2. Place the second blade/scale on the table (see that the gap between these two blades is 10cms), with 25cm on the table and 5cm in air. Keep a brick as weight on the scale/blade (fig-19).
3. Vibrate both blades with same force. Observe the vibrations and listen to the sounds produced.

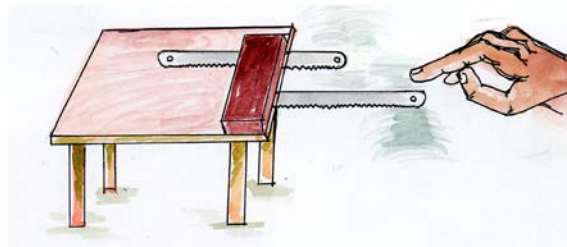

Fig-19: Vibrations of hack - saw blades

Repeat the same 2-3 times and record observations in the table-5.

Table 5

Blade length in Air	Vibrations more/ less	Sound loud/feeble
Blade-1 :20cm		
Blade-2 :5cm		

- What difference do you notice in number of vibrations of two blades?
- What difference do you notice in the quality of sound produced by them?

You would notice that the number of vibrations produced are less in the 20cm long blade when compared to the vibrations of the 5cm long blade. The sound produced by the 5cm blade is more shrill when compared to that of the 20cm blade.

The shrillness of a sound is known as **pitch**.

The number of vibrations per second (vib/sec) is called **frequency**.

The pitch of the sound depends upon its frequency.

In the above experiment number of vibrations per second in 20cm blade is less. It denotes that it has low frequency. Whereas the number of vibrations per second are more in 5cm blade so it has high frequency.

Thus the sound produced by a short blade (5cm) has high pitch and sound produced by long blade (20cm) has low pitch.

Conduct the above experiment with different lengths of the blades or metal scales and note your observations.

Think of lengths of male, female and children vocal cards and try to decide their voice pitch.

A bird makes high pitch sound and a lion makes low pitch roar. Which one does produces the sound of more frequency?

Give some more examples of natural sounds that you come across in your daily

life and differentiate them as low pitch sounds and high pitch sounds.



Do you know?

Pitch of the voices of the following is in ascending order.

Lion < adult man < adult women < child < infant < insect

- Can you guess the reason why?
- Do you find any difference in blowing the whistle and striking the drum?

5.7 Normal sound consists of mixed frequencies

In our daily activities, we hear many different sounds. But we generally do not concentrate on every sound that we hear. All these different sounds are produced with different frequencies and with different amplitudes. For example, the different sounds produced in a classroom before the commencement of the class. If we keenly observe these sounds, we can find that no two persons produce the same sound of equal pitch and amplitude.

- Why do we produce sounds with different pitches or amplitudes while speaking?

The variation in pitch and amplitude of sound during our speech helps us to communicate with others in the form of language.

Primitive man had no developed language, so he used to communicate with signs and some sounds which had no written equivalent. Later in the process of evolution these sounds became a source of a meaningful communication and eventually were converted into written forms. This led to the development of the full form of language which

Not only human beings but animals too have a mechanism of communication by producing sounds with different frequencies and amplitudes according to their need.

The parts of the speech organ which are involved in producing sounds are

- Vocal cords
- Lips
- Teeth & tongue
- Nose & throat

Naturally, the words that we utter do not have a single sound but are a combination of sounds with different frequencies and amplitudes. The sound produced for each letter possess a particular frequency. Thus, the word is a combination of different letters of different frequencies i.e., a word is sound of mixed frequencies. Sometimes the same word is uttered in different ways to express different emotions. For example, the word 'NO' is uttered in different pitches to express **negativity, anger and frustration.**

5.8 Music and Noise

- How do you feel when you hear sounds in busy traffic?
- How do you feel while listening to songs from a radio?
- Which of the above sounds are more pleasant to hear?

We enjoy the sounds in a music concert. They are pleasant to hear. But there are some sounds which are unbearable to hear like the sounds produced when a steel plate or utensil is dropped on the floor.

The sounds which are pleasant to hear are called **music**. The sounds which are not pleasant to hear are called **noise**. Noise is an irregular combination of sounds which are 'unpleasant' to hear. **Music** is a combination of sounds that are produced in an order and pleasant to hear.

Give some more examples for pleasant and unpleasant sounds.

5.9 Audible range

One of our sense organs, ear, enable us to hear a number of sounds. Are we able to hear all sounds produced in our surroundings?

- Do we hear the sounds produced by bats?

The sounds that a normal human being can hear are called **audible sounds**. The sounds that a normal human being cannot hear are called inaudible sounds. Frequency of the audible sound ranges from 20 vibrations/sec-20000 vibrations/second. This is called audible range. Frequency of inaudible sounds are less than 20 vibrations/sec or greater than 20000 vibrations/sec.

5.10 Sound pollution

Sound pollution is a serious problem like air, water pollution. It is harmful to human beings. We express the loudness of the sound in decibels (dB), which we have already learnt in this chapter. The sound produced in our normal conversation is about 60dB.



If the loudness exceeds 80dB, the sound becomes physically painful. If a person is being exposed to the sound of 80dB continuously it may lead to hearing problems.

Let us observe the sounds that are responsible for sound pollution.

In our surroundings there are many sounds causing sound pollution, like sounds of traffic, their horns, sounds in construction sites, sounds at industries, sounds at mines, sounds during explosions and firing of crackers, etc.

The unwanted sound in our surroundings leads to sound pollution. There are some more sources of sound pollution in our homes like mixer/ grinder, washing machines and motors etc.

Write some more sources of sound pollution in your surrounding.

5.10.1 Effects of sound pollution

What are the harmful effects of sound pollution?

The first harmful effect is loss of hearing. It also leads to several health related problems. eg: sleeplessness, hyper tension, increase in blood pressure, etc....

Discuss and list some more effects of sound pollution.

5.10.2 Measures to control sound pollution

We cannot stop production of sound but we can reduce sound pollution by some measures.

Let us list the steps which can be taken to reduce sound pollution:

- Attach silencers to bikes and other machines to reduce sounds.
- Manufacture machines that work with Sound

less noise

- During the use of TVs and music players tone down volume of sound.
- Plant trees to reduce sound pollution.

Discuss with your friends about some other measures to limit sound pollution and tabulate them.



Do you know?

M.S. Subbulakshmi was famous for



M.S. Subbulakshmi

her melodious music. It would be difficult to overstate the talent and the impact made by

Smt. M.S. Subbulakshmi, not just in the field of Karnatic music, but also as a philanthropist and a person who placed her life at the service to the country and people. She rendered her voice to devotional songs.

Ghantasala Venkateswar Rao was



Ghantasala Venkateswara Rao

famous playback singer. He was famous for his melodious voice. He sang more than 10,000 songs in Telugu, Tamil, Kannada, and

Malayalam and worked as a music director for over 100 films. His private songs were equally popular and his devotional songs are popular even today.



Key words

Vibration, vocal cords, medium, vacuum, eardrum, loudness, feeble, amplitude, decibel, pitch (shrillness), frequency, noise, music.



What we have learnt?

- Vibrating body produces sound.
- Human beings are able to produce sound with the help of vocal cords.
- Sounds travel through solids, liquids, and gases. It cannot travel through vacuum.
- The vibration of the ear drum caused by the sound produced by a vibrating body gives us sense of hearing.
- Loudness and feebleness of a sound are determined by amplitude of vibration.
- The intensity of sound is measured in dB (decibels)
- Pitch or shrillness is determined by the frequency.
- The number of vibrations per second is called frequency.
- Normal sounds consist of mixed frequencies.
- The hearing limit of sounds by human beings is called audible range.
- Sounds pleasant to listen are called music and unpleasant to listen are called noise.



Improve your learning



G7UGPX

I. Reflections on concepts

1. How can you explain that sound has energy? (AS₃)
2. Write the unit to measure the sound intensity. (AS₁)
3. Write the differences between the noise and music. (AS₁)
4. Explain the sources which produce sound pollution in your surroundings. (AS)

II. Application of concepts

1. The sounds of crickets (insects) make us close our ears. Why? (AS₁)
2. Write the names of any three musical instruments that you know. Explain how do they produce sound. (AS₁)
3. Draw the figures depicting low amplitude and high amplitude. (AS)
4. "Vibrations in a body produce sounds". How do you prove it? (AS)

III. Higher Order Thinking Questions

1. What is the effect of humidity on quality of sound propagation? Is there any difference in propagation of sound in air during the summer and winter seasons? Discuss. (AS₁)
2. How does sound pollution effect Bio diversity? Explain. (AS)



Multiple Choice Questions

1. An object which moves to and fro motion from rest known as..... ()
a) Linear motion b) vibration c) simple motion d) Angular motion
2. The number of vibrations produced per second is known as..... ()
a) Frequency b) Shrillness c) Vibration limit d) Decibels
3. The audible sound range of man is ()
a) 10-10000 Vibrations/sec b) 20-20000 Vibrations/sec
c) 30-30000 Vibrations/sec d) 40-40000 Vibrations/sec
4. The oval window has the surface area.....of the eardrum ()
a) 1/10 b) 1/20 c) 1/30 d) 1/40
5. The shrillness of a sound is known as ()
a) Pitch b) Vibration c) Intensity d) decibel



Experiments

1. Conduct an experiment to know the relationship between the intensity of sound produced by a body and its amplitude and prepare a report.
2. Conduct an experiment to Identify Pitch or Shrillness of different sounds and prepare a report.



Project Works

1. Collect photographs showing various situations of sound pollution and prepare a report.
2. Collect the photographs of different musical instruments and make a scrap book and a report on working process of the instruments.
3. Collect the photographs of local musicians and exhibit them in your class.



Do you know?

Golconda Fort - Hyderabad - Telangana State

It is a famous fort in India. It is famous for many engineering and architectural marvels. If you clap your hands at a particular point under the dome it reverberates and can be heard at the highest point of the fort which is about 1km away.



In class 6, we have learnt about shadows and we carried out many experiments with light rays and also discussed the rectilinear propagation of light i.e., light travels in a straight line. In class 7 we learnt the laws of reflection.

Let us recall some of them.

- A source of light, an opaque object and a screen are needed to form a shadow.
- Light travels in a straight line.
- When light gets reflected from a surface, the angle of reflection is equal to the angle of incidence.
- The incident ray, the normal at the point of incidence and the reflected ray all lie in the same plane.

You must have observed shadows and images in your daily life. Some questions might have come to your mind while observing these shadows or images!

- How can we get the image of a big building in a small mirror?
- Can we get the image formed by a plane mirror on a screen?
- Why is there right-left inversion (lateral inversion) when we look into a mirror?
- Why is the angle of reflection equal to the angle of incidence when a light ray gets reflected from a surface?

In this lesson we are going to learn about reflection of light on plane surfaces in detail so that we can answer the above questions. Let's start with some activities based on your previous knowledge.

6.1 Formation of image by a pinhole camera

Activity-1

Recall how an image forms in a pinhole camera that you have learnt in class 6. Draw a ray diagram of the formation of an image in a pinhole camera.



Imagine what would happen if we increase the size of the hole of the pinhole camera. Observe the flame of a candle with a pinhole camera making a big hole. Try to draw a ray diagram of the formation of an image in a pinhole camera with a big hole. Look at figure 1.

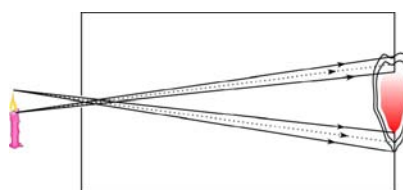

fig-1

By observing the figure we can understand that the light rays coming from

the top of the candle flame fall at different points on the screen. Similarly the rays coming from bottom of the candle flame also fall at different points on the screen. Thus we get blurred image on the screen due to the big hole of the camera as shown figure 1.



Think and discuss

- Does the explanation match your observation?
- What happens if the hole is much bigger i.e. equal to the size of the flame?
- If so, can we get an image of a flame on the screen of the pinhole camera? Why?
- What happens if we observe the same flame with the same pinhole camera from a long distance?
- What happens if we arrange two holes to the pin hole camera?

Think and answer. Do the experiment and check your answer.

Now think about reflection of light, and solve the task given below.

Activity-2

To find the shortest distance

A smart crow is on a tree at point 'A' as shown in figure-2. Some grains are on the ground [MN]. If the crow wants to take

a grain and reach the point 'B' on the other tree as early as possible (in least time), from where should the crow pick up the grain?

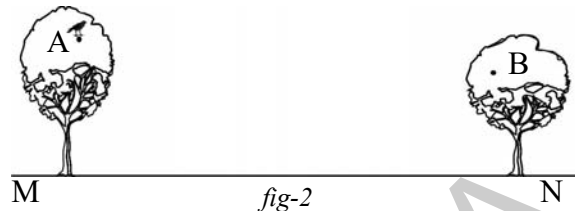

With the mathematical knowledge you have about angles and triangles can you guess the path that the crow selects? If you can't, read the following.

The crow can pick the grain from any point on the ground but the condition is; selecting a point on the ground to reach point 'B' from point 'A' in least possible time. If we assume that the speed of the crow is constant the path that the crow selects should be the shortest. Let us find the shortest path.

Observe some of the paths in figure-3.

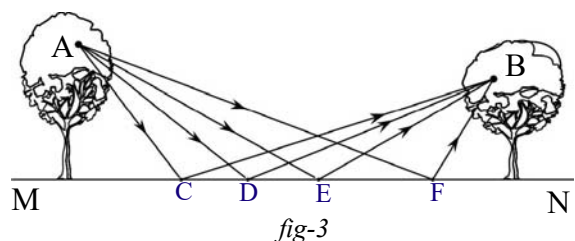

Which among the paths ACB, ADB, AEB and AFB is the shortest path?

To compare the lengths of these paths, we make duplicates of them in such a way that all the duplicate paths meet at point G as shown in figure-4.

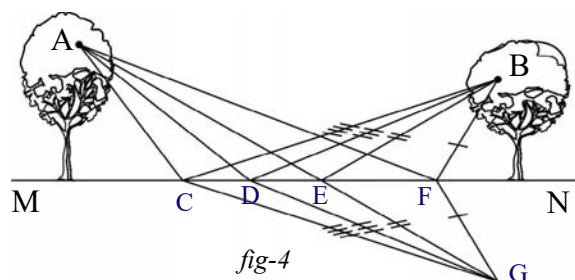

In the figure-4, $CB = CG$. The length of path $ACB = AC + CB = AC + CG = ACG$. Thus the length of the path ACG is equal to the length of the path ACB . Similarly, length of the path $ADB =$ length of the path ADG length of the path $AEB =$ length of the path AEG length of the path $AFB =$ length of the path AFG

If you observe Fig-4 carefully, you will notice that, among the paths ACG , ADG , AEG and AFG , the shortest path is AEG , because it is the straight line distance between points A and G . You can measure and check this using a scale. As $AEG = AEB$, path AEB is the shortest path to reach point B from point A . It would take the least time. So the smart crow will pick the grain from point E .

Observe the path AEB once again in figure-5.

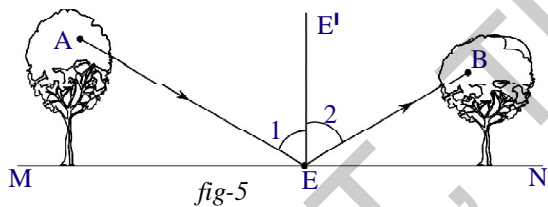

If we draw a normal EE' at point E , we can easily find that angle AEE' (angle 1) is equal to angle $E'EB$ (angle 2).

Like the crow in the above situation, light also selects the path which takes the least time to travel. This principle was first given by **Pierre de Fermat**, a French lawyer and an amateur mathematician.

It is also applicable to reflection of light. When light gets reflected from a surface, it selects the path that takes the least time. That is why the angle of incidence is equal to the angle of reflection as shown in figure-5.

- Which line segment can be considered as a mirror in the above activity?
- We know that plane mirror is a surface. How can we denote it in ray diagrams?

Let us know about plane mirror, before going to discuss reflection of light on plane surfaces and to know how to draw ray diagrams.

6.2 Plane mirror



Plane mirrors are made by depositing a Silver layer on one side of a glass plate and then the Silver layer is protected by a paint.

Silver metal is one of the best reflectors of light. But now-a-days instead of Silver, a thin layer of Aluminium is used to deposit on glass plates, because Aluminium is much cheaper than Silver and it also reflects light very well. Hence the thin layer of Silver or Aluminium is the reflecting surface at the backside of the mirror.

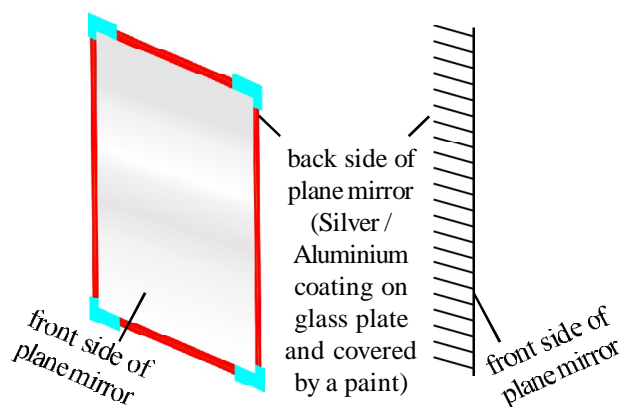

Fig-6(a)
Plane Mirror

Fig-6(b)
This is how we represent
plane mirror in diagrams

Activity-3

Check your understanding of reflection

Look at figures 7(a) and 7(b). Let us suppose that you have been given a plane mirror strip.

- What will you do to obtain figures that are shown in figure 7(b) using mirror strip and figure 7(a)?

Place the plane mirror strip on the figure shown in 7(a) in such a manner that you see one of the figures shown in figure 7(b). The procedure is shown in figure 7(c).

- Are you able to obtain all figures shown in 7(b)?

fig-7(a)

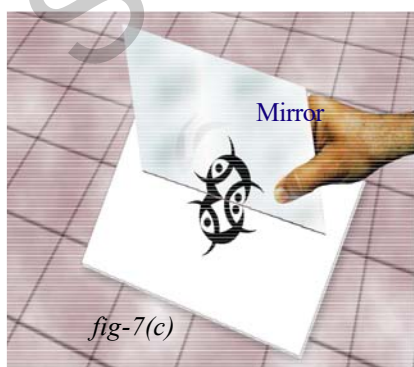
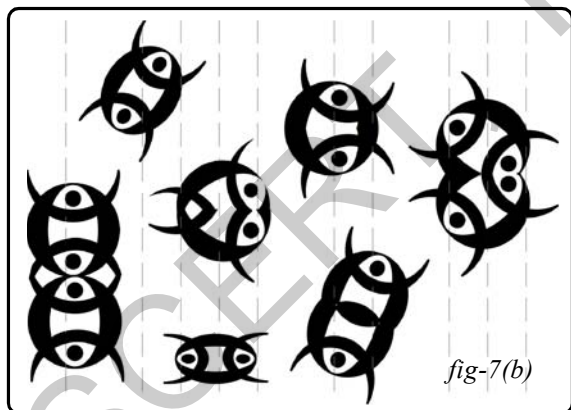
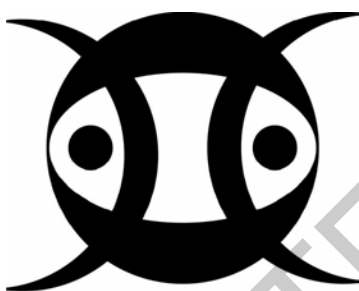

fig-7(c)

Take the help of your friends to complete the task.

Let us begin the detailed discussion on reflection of light by plane surfaces.

6.2.1 Reflection of light by plane mirrors



Lab Activity

Aim: Verification of laws of reflection

Required material: mirror strip, drawing board, white paper, pins, clamps, scale and pencil.

Procedure: Take a drawing board and fix a white paper on it with the help of clamps. Draw a straight line AB at the centre of the paper and also a normal (ON) to AB at the point 'O'. Draw a straight line PQ making certain angle (angle i) with ON as shown in figure 8. Fix two pins at the points P and Q on the paper vertically. Observe the image P^1 of the pin P and Q^1 of the pin Q, in the mirror kept along the line AB. Fix two more pins R and S such that they are in the same line as that of P^1 and Q^1 . Join R, S and O as shown in figure 8.

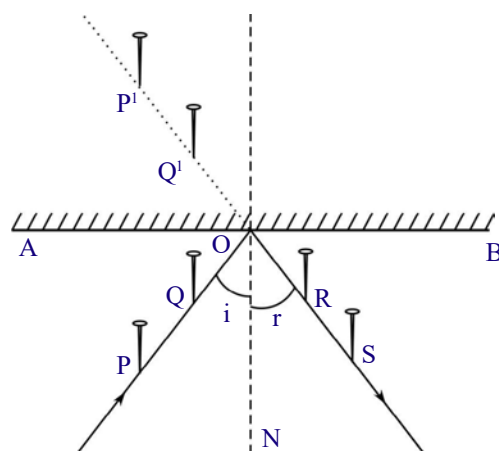

fig-8

Measure the angle (r) between RS and ON (angle of reflection). You will find that angle of incidence = angle of reflection. Repeat the experiment for different angles of incidence and measure the corresponding angles of reflection (r).

Record your observations in table - 1

Table-1

S.No.	i	r	Is $i = r$ yes/no

- Is the angle of reflection equal to the angle of incidence in all cases ?

In which plane does the incident ray, reflected ray and the normal lie (2nd law of reflection of light)? Let us discuss this.

6.2.2 Plane of reflection

In the above activity, the incident ray is the ray which passes through the points P and Q touching the paper. The reflected ray is the ray which passes through the points R and S touching the same paper, and ON is the normal to the mirror at point O.

- Do the two rays and the normal lie in the same plane? If yes, which is that plane?

If the incident ray, reflected ray and normal are in the plane parallel to the plane of the paper, where will that plane be?

Assume that the heads of all pins pierced at points P, Q, R and S in the above activity are at the same height. The incident ray is the ray which passes through the heads of pins which are located at points P and Q, and reflected ray is the ray which passes through the heads of pins which are located at points R and S.

Then,

- Where will the normal be?
- In which plane will the incident ray, reflected ray and the normal lie?

The plane in which the incident ray, reflected ray and normal lie is the **plane of reflection**.

Assume that the heads of the pins which are located at the points P and Q are not of the same height.

- How will the incident ray be?
- How will the reflected ray be?
- How will the normal be?
- How will the plane of reflection be?

Arrange two pins with different heights. Arrange the incident ray, reflected ray and the normal with the help of spokes of a cycle. Then think of the plane of reflection.

- How does a mirror form the image of a pin or any object? Let us discuss.

6.2.3 Formation of an image by a plane mirror

Case - I: Point Object

In figure 9, O is a point object. Some rays from O reach the mirror and get reflected.

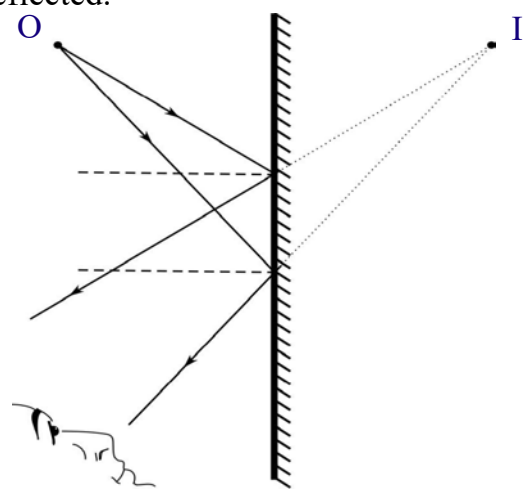
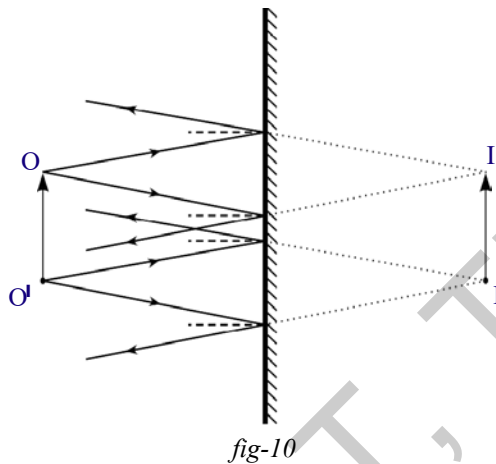

fig-9

When we look into the mirror, the reflected rays seem to be coming from the point I. So point I is the image of point object O. Observe the distances of object O and image I from the surface of the mirror and try to compare these distances by approximate estimation in figure 9. We find that these distances are equal.

Case II: Object with certain height

Let us assume that an object (OO') is kept in front of a mirror as shown in figure 10. Draw a few incident rays from the object to the mirror and reflected rays from the mirror using laws of reflection. Your drawing may look like that shown in figure 10.



In the figure, the rays coming from the point O get reflected from the mirror and seem to be coming from the point I. So we say I is the image of O.

The rays coming from the point O' get reflected from the mirror and seem to be coming from the point I' . So we say I' is the image of O' .

The rays coming from the middle part of the O and O' will form their own images between I and I' .

Thus, $I'I'$ is the image of the object OO' .

- What is the size of the image compared to the size of the object?

Let us discuss some of the characteristics like size, distance and right-left inversion of an image formed by a plane mirror.

6.2.4 Characteristics of an image formed by a plane mirror

Take an object, say pen or pencil. Put it in front of a plane mirror, touching the surface of the mirror.

- What do you say about the size of the image compared to the size of the object?
- Move the object towards your eye. What do you observe?
- Is the size of the image decreasing or increasing?

Figure 10 shows the formation of an image by a plane mirror. In that figure, you might have noticed that the size of the image is equal to the size of the object. Why does the size of the image seem to be decreased when you move the object towards your eye?

To understand this see figure 11, which shows how our eyes judge the size of an object.

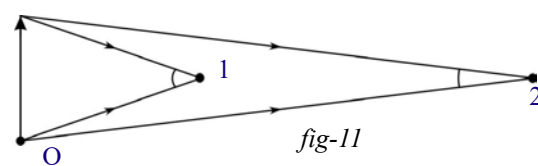

Observers 1 and 2 are looking at the object which is at point O. It looks smaller to observer 2 than to observer 1, because the light rays coming from the object make a smaller angle at the eye of observer 2 who is at a larger distance compared to observer 1. (Confirm your self by measuring these angles in Fig-11). The angle plays a role in judging the size of the object.

In the same way when we move the object from the mirror to our eye, the image in the mirror seems to move back in the mirror. Then the distance from the image to our eye increases. The angle made by image at our eye is smaller than the angle made by the object. That is why the image looks smaller than the object.

When you stand in front of a mirror you might have observed that the distance of your image in a plane mirror seems to be equal to the distance between the mirror and yourself. What you observe is generally true. You can verify this by observing figure-10.

You also might have observed the right-left inversion of your image in a plane mirror.

- Why does an image suffer lateral (right-left) inversion?

See figure-12.

- What do you understand from the figure-12?

The light rays which come from our right ear get reflected from the plane mirror and reach our eye. Our brain feels that the ray (reflected ray) is coming from the inside of the mirror (shown by dotted line in the figure-12). That is why our right ear looks like left ear in the image.

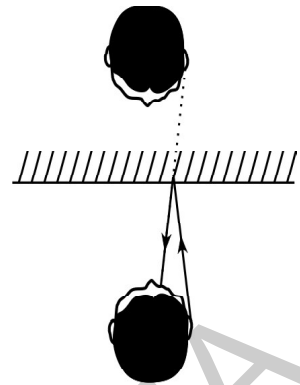

fig-12

Now observe the lateral inversion of a letter **J** with a ray diagram in figure-13.

Think of the process of image formation by a plane mirror and explain lateral inversion by observing figure-13.

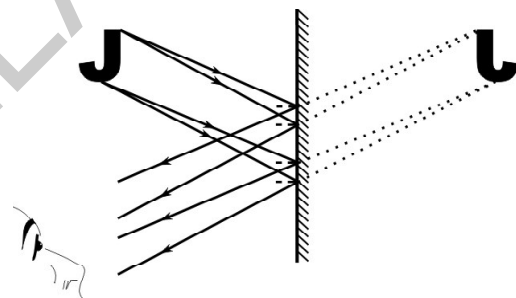

fig-13

As shown in figure - 14 arrange some Telugu, English alphabets in front of a plane mirror and observe the images.

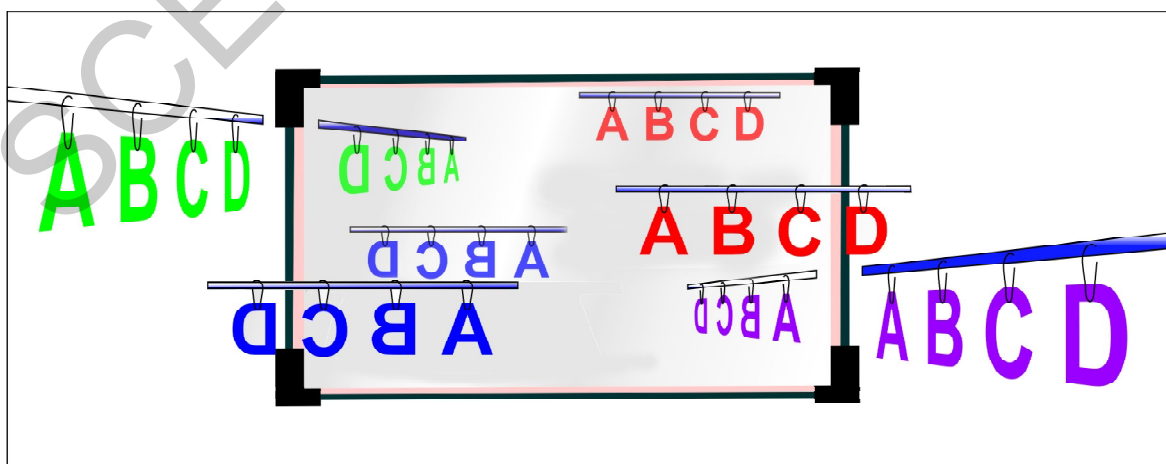

fig-14

6.2.5 Uses of plane mirrors in our daily life

1. Plane mirrors are used for dressing purpose of ourselves.
2. Plane mirrors are used for decoration on walls of some shops like Jewellery shops, Sweet shops, Barber shops etc. to observe the shop in all directions, and to get multiple images of things and persons.
3. Plane mirrors are used in making some optical instruments like periscopes etc.
4. Some type of Solar cookers are made by using plane mirrors.



Key words

reflection, incident ray, reflected ray, normal, angle of incidence, angle of reflection, plane of reflection, lateral inversion, object distance, image distance, real image, virtual image,



What we have learnt?

- Light selects the path which takes the least time to travel (Fermat's Principle). It is also applicable to reflection of light.
- Image of a real object in a plane mirror is virtual, erect and the same size of the object.
- The image in a plane mirror appears to be small because of the small angle subtended at our eye.
- Image in a plane mirror suffers lateral inversion.



Improve your learning

I. Reflections on concepts.

1. If a ray incidents normally on a plane mirror, what will be the angle of reflection?(AS₁)
2. Explain the laws of reflection. (AS₁)
3. Explain the process of formation of an image with a pinhole camera with help of a diagram. (AS₃)
4. Why does the image in plane mirror suffers lateral inversion? (AS₁)
5. Draw a ray diagram to understand the formation of image for a pointed object by a plane mirror and explain it. (AS₃)



II. Application of concepts

1. In the adjacent figure, AO and OB are incident and reflected rays respectively. $\angle AOB = 90^\circ$. Find the values of angle of incidence and angle of reflection? (AS₄)

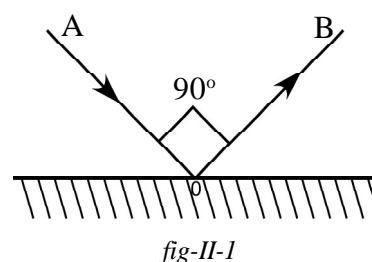

2. Bharath stands in front of a plane mirror at a distance of 5m. from the mirror and observes his image in the mirror. If he moves 2m. towards the plane mirror, then what will be the distance between Bharath and his image? (AS₄)
3. Explain diagrammatically the image of letter 'B' in a plane mirror. (AS₃)
4. Why can't we see our image in a white sheet of paper though it reflects light? (AS₂)
5. Discuss the merits and demerits of using mirrors in building elevation? (AS₁)

III. Higher Order Thinking Questions.

1. Observe the adjacent figure. AB and BC are two plane mirrors arranged at 120° . A ray incidents at and angle 55° on AB. Find the value of 'x'? (AS₁)

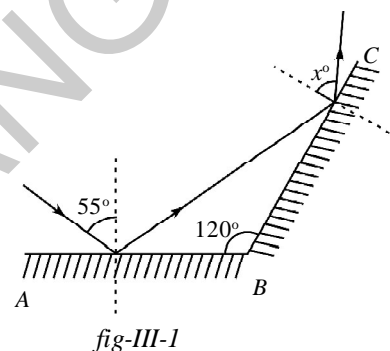

2. Niharika holds a clock in her hand, which shows the time 3'O clock. If she observes the clock in a plane mirror, what will be the time that the clock show in the plane mirror? (AS₁)

3. Two plane mirrors are fixed at right angles to each other and an object is placed between them as shown in the figure. Trace the path of the rays by which an observer see the final image in one of the mirrors. (AS₄)

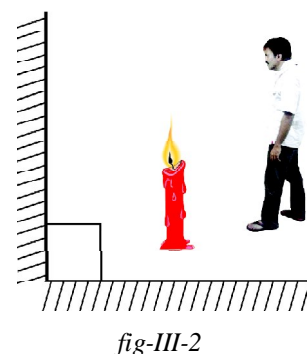

4. Two divergent rays originating from the same point have an angle of 10° between them. If they strike a plane mirror with same incident angle, what will be the angle of reflection? (AS₁)
5. The size of the image in the mirror seem to be decreased when you move the object towards your eye from the mirror. Draw the diagram showing angles depicting the situation. (AS₅)



Multiple choice questions

1. Angle of incidence = Angle of reflection. This rule is explained by _____ principle. ()
(A) Fermat (B) Newton (C) Archimedes (D) Pascal
2. Which of the following letters doesn't suffer lateral inversion. ()
(A) C (B) O (C) B (D) N
3. A ray of light incidents on a plane mirror at an angle of 90° to its surface. What will be the angle of reflection. ()
(A) 0° (B) 90° (C) 45° (D) 180°
4. If we move an object away from the plane mirror the size of images seems to be ()
(A) Increases (B) decreased ()
(C) of the same size (D) Image can't be seen
5. Which of the following is incorrect with respect to the image in a plane mirror. ()
(A) Image is erect (B) Size of the image is same as the size of object
(C) Laterally Inverted (D) Image is real



Experiments

1. Verify laws of reflection experimentally.
2. Find the plane of reflection experimentally for the incident ray which passes through the heads of the two pins pierced in front of the mirror as shown in figure 8.



Project Works

1. Make a solar heater / cooker with plane mirrors and write a report on the process of making.
2. Generally periscopes are made in the shape of "Z" make your own periscope in the shape of "C". Discuss the problems faced while using the periscope you made in shape "C". Draw the ray diagram to explain the formation of image in 'C' shaped periscope.



Deekshita is trying to take down a pickle jar which is at the top most section of a shelf.

Grandfather: Be careful! it may fall down and break.

Deekshita: No, problem grandfather! This is a plastic jar. It won't break.

Deekshita realizes that Grandfather was thinking of the clay jars that were used in olden days. Nowadays plastic jars are used and they are unbreakable.

What else has changed, she wondered? Help Deekshita to find out.

Activity-1

Identifying articles and materials that used for various purposes

Have a look at table 1. In Column (A) gives the names of certain situations and articles are given. Ask your grandparents or other older people about the names of the materials which are used for the items given in column (A) 30-40 years ago and write them in column B. Then in column C, write the names of materials being used at present. Few examples are given to guide you.

Table-1

Situations/ Articles (A)	Articles/ Materials used 30-40 years ago (B)	Articles/ Materials used Today (C)
Containers for storing pickle	Porcelain jars	
Packing food for a journey		Plastic tiffin boxes
Water pipes in the house		
Hair combs		
Vessels for cooking food	Copper vessels	Steel vessels
Fuels used to cook food		
Fuel used in a train engine	Coal	
Luggage for carrying clothes	Metal trunks	
Water buckets, pails		
Water storages in houses		Plastic buckets
Construction material		
Jewellery		
Furniture (chairs, cots)		

From activity 1, you have a long list of materials. Some of them like wood, metals (iron, silver, gold etc) were used ten years, fifty years and even hundred years ago. Do your grandparents remember using plastic when they were young?

Now think and write the answers:

- How many of the materials that you have listed were available 10 years ago?
- How many of them were available 50 years ago?
- How many of them were available 100 years ago?

In case you have any doubt, you can take the help of your social teacher and your elders too.

You find that some materials such as wood and gold that are used today, were also used even thousands of years ago. But others like plastics are of recent origin.

The progress in science and technology gives us new products every day. The branch of science which deals with materials is called material science.

7.1 Sources of materials

We know that we get wood from trees. Do you know that we get metals like iron, copper from their ores? Which material is used to make plastic or glass?

Do you remember reading about petrochemicals in the chapter on synthetic fibres and plastics.

- How do we obtain various materials?

Table 2 gives some answers.

After looking at table 2, you find that the materials used earlier were obtained from soil (clay, sand), water, ores, etc. Soil, water and air were not only sources of materials used earlier but also sources of energy.

Now, plastic has replaced many materials used earlier. Petrochemicals are used for making plastics. Many materials that we use for different purposes today come from various sources present in nature. Therefore, soil, water, air, petrol etc. are called natural resources.

7.2 Exhaustible and Inexhaustible Resources

Now, we have to think about few questions to understand about need and importance of natural resources.

- Will the above resources be available forever?
- Won't we ever run out of air?
- Won't we ever run out of water?

Table 2

Material	How is it obtained?
Glass	By melting sand with other materials and then, cooling it rapidly
Clay	By mixing the mineral kaolinite with water
Wood	From dried up trees
Plastics	From petrochemicals
Metals	From their respective ores

- Can these resources be exhausted by human activities?
- Do we have unlimited supply of coal and petroleum?



Do you know?

Wind mills :

Wind is an important natural resource. Sail boats and sailing ships have been using wind power since thousands of years. Wind mills were used to grind corn and to pump sea water to make salt.



Some energy sources like air and water are not exhaustible on usage. Hence these are called Inexhaustible resources. Coal and petroleum etc, are the energy sources which are exhaustible on usage. If this situation continues, in future we might have to depend on solar energy.

- Is wood an inexhaustible resource? Think about using wood for making furniture.
- What will happen if all the forests are cut down and the wood is used for various purposes?
- How long do you think it would take to grow the forests again?

There are many resources like trees which will be depleted if we don't make judicious use of them.

- How long the fossil fuels like petroleum will be available? Is it inexhaustible?

We need petroleum not just as a fuel but also for preparation of petrochemicals and several other uses as we will see later in this chapter.

Resources therefore can be classified as inexhaustible and exhaustible depending on whether they are expected to last forever or not.

Activity-2

List out the natural resources which are limited and which are abundant and record them in table-3.

Table -3

Resources Abundant	Resources Limited

Is petroleum exhaustible?

If we see the history of petroleum production, from 1859 to 1969, the total production of oil was 227 billion barrels. *(In the oil industry the barrel is the unit for measuring petroleum volume and one barrel equals 159 litres).* 50 percent of this total was produced during the first 100 years (1859-1959), while the next 50 percent was extracted in just ten years (1959-1969). Today our consumption rate of oil is far excess than that of the rate of its formation. Earth takes more than one thousand years to form the oil that we consume in one day. By about 2015, we would have consumed half of the total reserves of the oil. It would become more and more difficult to extract oil in future.

- What will happen if fossil fuel like coal and petroleum are completely exhausted?
- What would be our future energy resources?

The entire Research and Development (R&D) in the field of sources of energy shows that at the present rate of use of the conventional energy sources like fossil

fuels will not last for long. Presently only 10% of non-conventional ever inexhaustible energy resources like solar energy, wind energy, tidal energy, etc, are used.

- Are the fossil fuel resources available sufficiently to meet the future energy needs?
- What actions are required to meet the future energy needs?



Do you know?



Bio -diesel an alternative fuel source

Bio-fuels are one of the major non-conventional energy resources. They are **non-toxic** and **renewable**. Bio-diesel is one of the bio-fuel which is an alternative or additive fuel source to the

standard diesel fuel which is used now. It is made from the biological ingredients instead of petroleum or crude oil. Bio-diesel usually made from the plant oils or animal fat through a series of chemical reactions. It is safe and can be used in diesel engines.(But bio-diesel requires more cultivatable land which may affect shortage of food production in future.)

7.2.1 Coal, Petroleum and Natural Gas as Fuels

Earlier people used kiln (*poyyi*) for cooking food, in which wood is used as fuel but now people use gas stoves or kerosene stoves. Earlier food was cooked using wood as fuel, then coal, now kerosene and cooking gas (LPG) are being used.

Fuel is needed not only for cooking but also for transport. Different vehicles (train, bus, cars, two-wheelers) are used for travelling long distances and they use different fuels. People also travel by ships. What fuel is used there? Fuel is also required for electricity generation.

Earlier you read that wind power was used in wind mills. Then the steam engine which used coal was invented during the industrial revolution. During this period steam engine was used to power everything from cloth looms to vehicles on land and water.



Fig-1

Coal was the most important fuel in the 19th Century. It is an exhaustible resource but we can meet our needs for another 250-300 years at the current rate of use. Till 1950, coal accounted for half of the electricity generation in the world.

Coal was replaced by petroleum with the invention of more efficient engines in different vehicles. Now, coal is mostly used to produce electricity in thermal power plants.

Coal is an ancient gift serving modern society.

Coal has been known and used for thousands of years. It is one of our earliest source of heat and light. But it became a fuel of importance only after the industrial revolution which led to an increase in demand as fuel.

Do you know that the coal obtained from the fire wood and the coal used in vehicles and factories are different? Coal used in factories is mined from the earth's crust. The coal obtained from the fire wood is usually charcoal.



Do you know?

Petrol and diesel which are used in vehicles today are obtained from mineral called petroleum. Petroleum has been known almost since prehistoric times. More than 4000 years ago, asphalt (Petroleum Product) was used in the construction of walls and towers of Babylon. There are also records from ancient China about shallow wells being dug to get petroleum. But what did our ancestors do with this petroleum? They mainly used for making their wooden boats waterproof, as a fuel for lamps and in some traditional remedies. We realized the importance of petroleum only after science and technology progressed to give us petrochemicals and petrol to run engines.

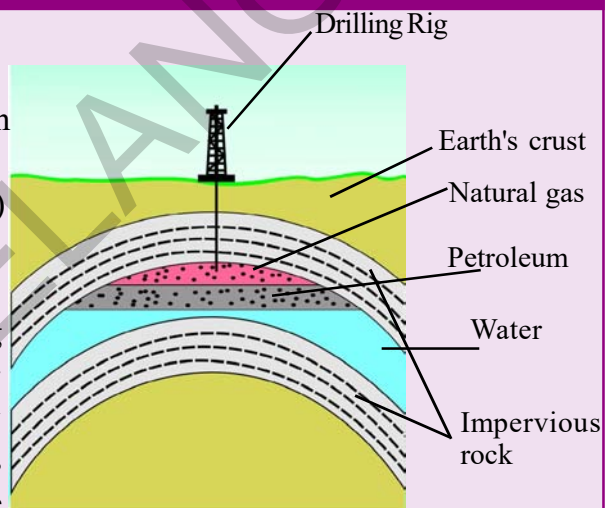

7.2.2 Natural gas is another important fuel

Natural gas is found trapped between impervious rocks, sometimes along with petroleum and sometimes without petroleum. Previously, this gas was allowed to escape or even burnt while pumping out the petroleum.

Now, the natural gas is treated as equally precious because it is safer for the environment. Natural gas is stored under

high pressure as compressed natural gas (CNG).

The exploration for more petroleum and natural gas are going on under the supervision of ONGC (Oil and Natural Gas Corporation) throughout India. In India gas fields have been discovered in Tripura, Mumbai High, Krishna, Godavari delta and Jaisalmer.

7.2.3 Other uses of coal, petroleum and natural gas

Most of us think petroleum is a source of fuel. But advances in our understanding of various chemical processes has led to the use of both coal and petroleum as the starting materials for a wide variety of products.

Petroleum is a complex mixture. It is separated into various components by a separation technique known as **fractional distillation**

Look at the figure-2. We can see the various products which are now being obtained from petroleum. Initially, the separation techniques available were not advanced and could separate only a few components from the petroleum mixture. One of the first fractions to be separated from petroleum was kerosene which was found to be better fuel than the petroleum. Now, we can separate many more components. Fuel gas, petrol, diesel etc. are all obtained from petroleum mixture. These components of petroleum are then used to obtain other products.

Refining of Petroleum

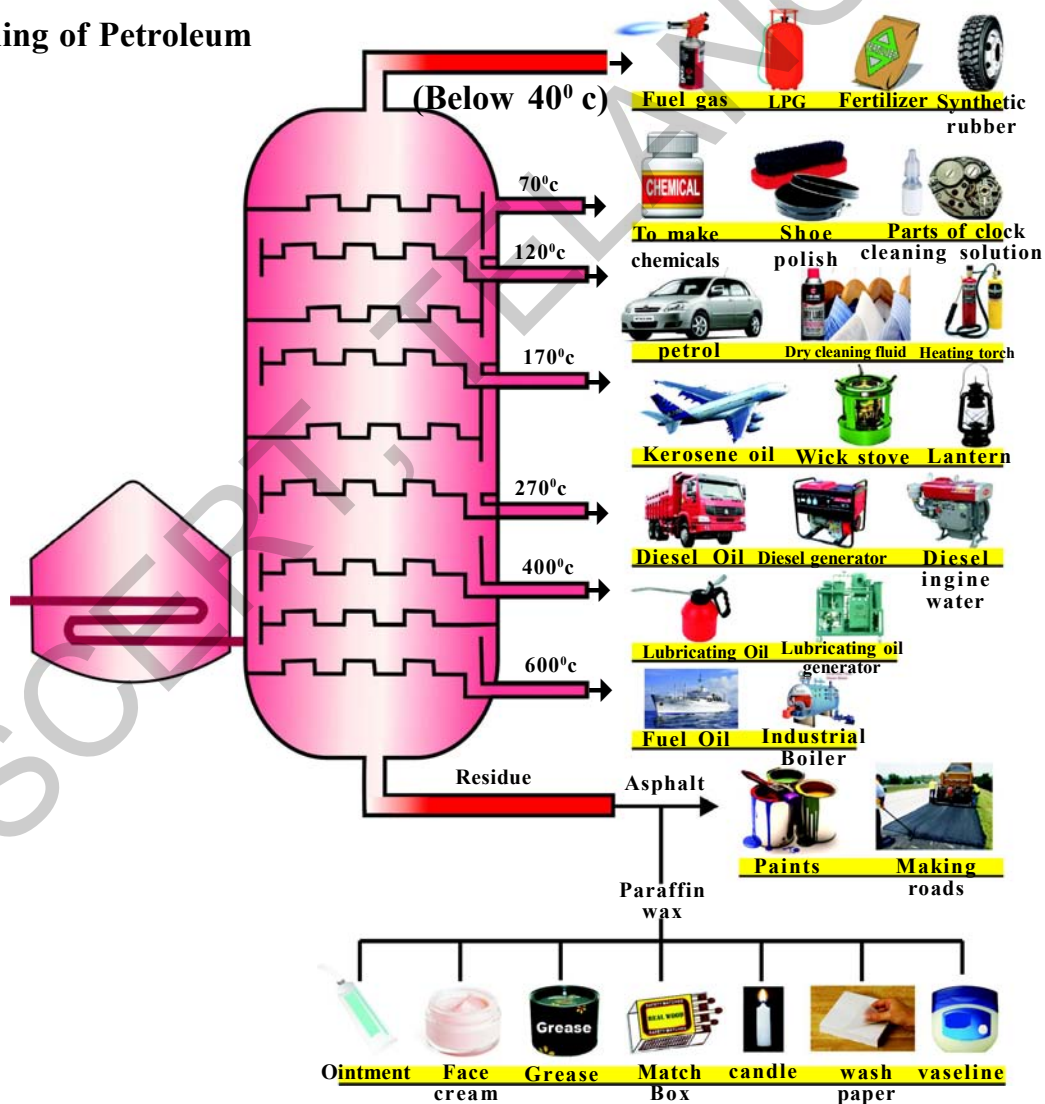

Fig-2 : Uses of coal and petroleum

Activity-3

Identifying various uses of petroleum.

Look at the figure-2 and find the other uses of petroleum and its products. Fill in the table.

Table -4

Name of the petroleum product	Uses		
Petrol			
Fuel Oil			
Kerosene			
Diesel			
Paraffin Wax			

Coal:

Coal is not as versatile as petroleum but it is also very useful. Look at the figure-3.

We can see that coal gives us coke, coaltar and coal gas. Each of these components has several uses.

When coal is heated in air, it burns and produces mainly carbon dioxide gas. Coal is processed in industry to get some useful products such as coke, coaltar and coal gas.

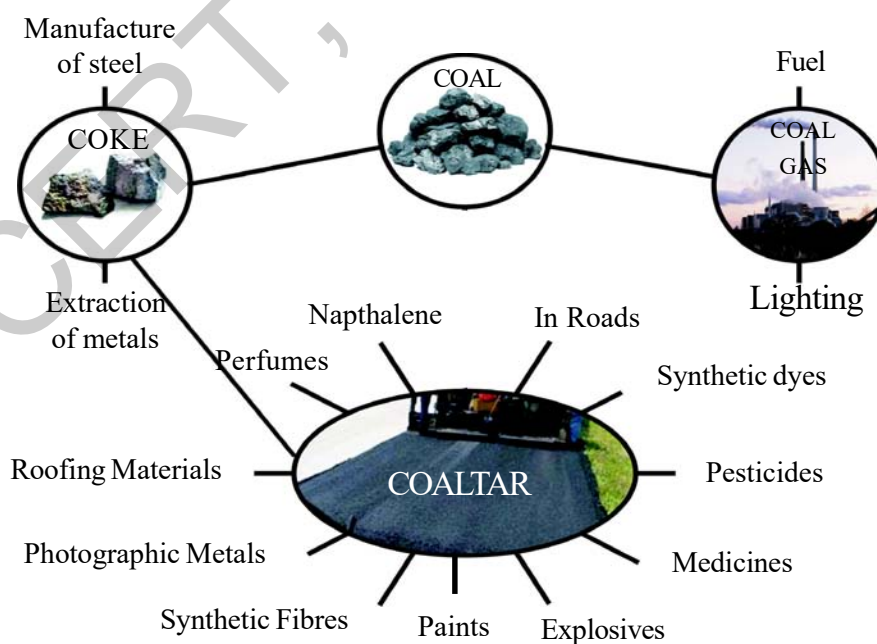

Fig-3: Uses of coal and its products

Coke

It is a tough, porous and black substance. It is an almost pure form of carbon. Coke is used in the manufacture of steel and in the extraction of many metals.

Coal tar

It is a black coloured thick liquid with an unpleasant smell. It is a mixture of about 200 substances. Products obtained from the coal tar are used as starting material for manufacture of various substances like synthetic dyes, drugs, explosives, perfumes, plastics, paints, and roofing materials etc. Interestingly naphthalene balls used to repel moths and other insects are also obtained from coal tar.

Coal gas

Coal gas is obtained during the processing of coal to get coke. It is used as a fuel in many industries situated near the coal processing unit.

Activity-4

Identifying uses of coal products.

Observe the figure-3 and list out the uses of coal products in the following table-5. You can collect more information by discussion with elders and with your friends.

Table-5

Coke	Coal Tar	Coal Gas



Lab Activity

Aim: To show that when we heat high quality coal (carbon content is more) the evolved gas burns.

Material required: Two boiling tubes, Rubber corks, iron stands, delivery tube, jet tube, Bunsen burner.

Procedure: Take a spoon of powdered coal into a hard boiling tube and fix it to a stand as shown in the figure. Close the test tube with a rubber cork and connect it to another boiling tube which is partially filled with water and has fixed to other stand, with the help of 'U' shaped delivery tube as shown in the figure. Arrange a jet tube to the cork of second boiling tube. Heat the boiling tube containing coal strongly with

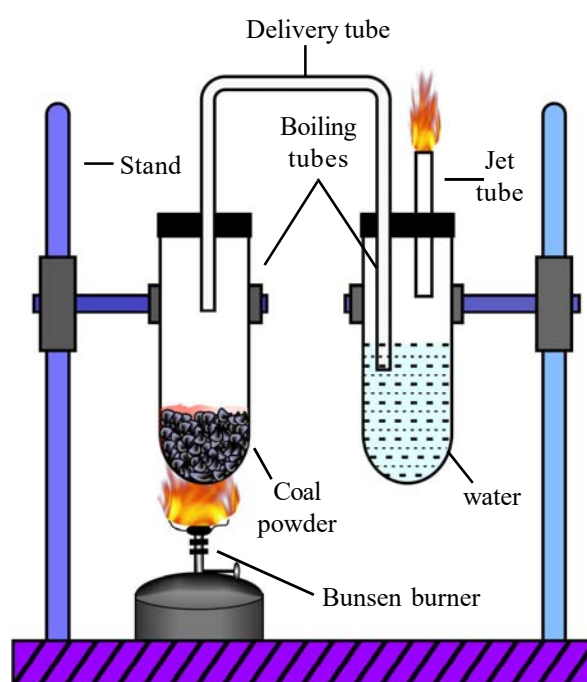

Fig-4: Burning the coal

- What do you observe?

You may notice that the brownish black vapours evolved in the first boiling tube. These vapours are passed through water in the second boiling tube. Colourless gas bubbles evolve from the water. If you burn the gas that is evolving through the jet tube, you can witness a bright flame at the nozzle.

Repeat the above experiment by using lime water, soap water instead of water used in second boiling tube.

- What do you observe? Give reasons for the changes you observed in two experiments.

- What inference can you draw from these two experiments?

Natural gas and petrochemicals

Natural gas is not just an important domestic and industrial fuel but also used in the manufacture of fertilizers.

Petrochemicals: The useful substances which are obtained from petroleum and natural gas are called petrochemicals. These are used in the manufacture of detergents, synthetic fibres (Polyester, Nylon, Acrylic polythene etc). Due to its great commercial importance petroleum is also called as **liquid gold**.

7.2.4 Some petrochemical products

Petrochemicals are used in preparation of various articles as substitutes for materials like wood and metals which are limited. They are also used to manufacture several new products that cannot be obtained from wood, soil, metals etc. The table-6 shows how petrochemicals are now used in all walks of life.

Table - 6

Agricultural Sector	Industrial sector	Domestic and other sectors
Plastic tubes, baskets, storing box, cultivation implements, fertilizers	Cars, motor boats, communication devices, construction materials, paper industry, belt and straps, tyres.	Medical equipments, clothes, bedding, socks, furniture, paints, washing liquids, fibre, cosmetics, medicines, polishing liquids etc.

Look at the table-6 given above. Think of all materials which you use in a day. Can you imagine spending a day without using petrochemical products? List how often you use products obtained from petrochemicals. Can you imagine life 100 years ago when these are not available?

We use so many products now, which we did not have 100 or even 50 years ago.

Increased consumption has led to increased production of waste material which created disposal problems. For example, for the last 3 years the use of materials obtained from coal and petroleum to make a wide variety of cheap plastics has revolutionised. These materials also created a major pollution to the environment.

To understand this, explore the processes by which coal and petroleum are formed.

7.3 Formation of coal

The plants in large and dense forests in low lying wetlands got buried under the soil due to the natural processes like floods and earthquakes. As more soil deposited over them, the organic matter was compressed. The temperature also rose. As the organic matter sank deeper and deeper, under high pressure and high temperature, these vegetation slowly converted to coal. As coal contains mainly carbon, the slow process of conversion of dead vegetation into coal is called **carbonisation**. Since coal was formed from the remains of vegetation, it is called **fossil fuel**.

7.3.1 Formation of petroleum

Petroleum was formed from the remains of tiny organisms called **plankton** that were found in the bottom of seas and oceans. Plankton have tiny droplets of oil inside their bodies. As these organisms died, their bodies settled at the bottom of the sea or ocean and covered with layers of sand and clay. Over millions of years, due to absence of air, high temperature and high pressure these dead organisms transformed into petroleum and natural gas.

Like coal, petroleum and natural gas were also formed from the dead remains (fossils) of living organisms. Hence they are also known as fossil fuels.

7.3.2 Why are coal and petroleum so versatile?

Coal consists of mainly carbon while petroleum consists of a mixture of compounds called hydrocarbons (they contain mainly hydrogen and carbon). These compounds make good starting materials for other compounds based on carbon. Carbon is very versatile and is the basis for most of the materials. Therefore, coal and petroleum consist carbon are very important starting materials for synthesising variety of useful compounds.



Do you know?

Alternatives to natural gas

The gas resources which are not conventional like natural gas are known as non-conventional gas resources. Our country has enormous non-conventional gas resources like coal bed methane and gas hydrates. These are not in commercial production phase due to the lack in proper technology. In future, when the oil era is expected to end, the only way to meet the energy demands will be by producing this non-conventional gas.

7.3.3 Conserving coal and petroleum

Why does the price of petrol go up all the time?

In simple terms, the price of anything depends on how much of it is available and how essential it is.

Both coal and petroleum are exhaustible resources, but we need them, both as fuel and as starting materials for synthesising new compounds. Since supplies are limited they are becoming more expensive as the demand for them increases.

We have to conserve these resources as much as possible, and also look for alternatives for these resources.

Let us look at the issue of conservation. We can reduce the consumption of both coal and petroleum by

(i) opting for a different model of development which does not depend on these resources

(ii) reduce the wastage of these resources.

Since the first option is right now impracticable, second option of reducing wastage is to be practiced. The governments of many countries are working on this problem of finding alternative technologies to reduce the use of fossil fuels.

7.4 Misuse of energy resources and consequences

In our daily life while doing various day to day activities we use many types of energy resources and fuels without giving a thought about the exhaustibility of these resources and consequences. For example in urban areas dryers are used in washing machines which consume electric energy, even though abundant source of heat energy in the form of sunlight is available around us. Similarly motor bikes are used even for shorter distances. Walking shorter distances or using bicycles saves not only fuel but also keeps good health.

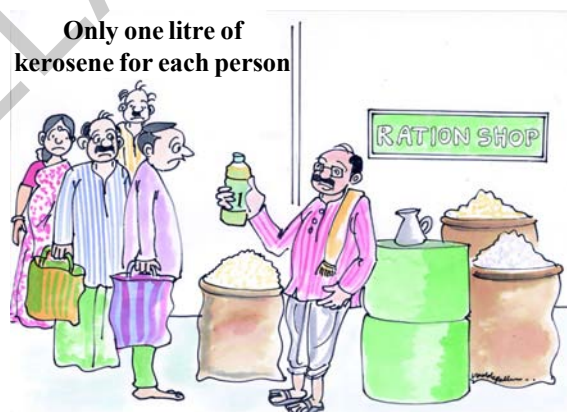

Fig-5

- Can you give some more examples where energy or fuel resources are misused in our daily life?
- Can you suggest alternate ways to save the fuel resources?
- How is biodiversity effected by excessive use of fossil fuels?

Activity-5

Group discussion on misuse of fuel resources and its consequences.

Discuss in small groups how fuel resources are being misused in our daily life while doing various activities like...

- a) transportation,
- b) cooking
- c) industrial use
- What are the consequences of misuse of fuels? Prepare a report.
- What methods could you suggest to prevent the misuse of fuels?

Harmful effects caused during use of fuels

Most of the harmful effects are due to carelessness of handling petroleum products. For example, crude oil and refined fuel spills into sea from tanker ship by accident causes damage to natural eco system and kill sea birds, mammals, shell fish and other organisms.



Utilisation of these fuels leads to some more harmful effects. Let us see that

- Burning fuels releases carbon dioxide which causes climate changes and leads to global warming.
- Coal fired power plants emits mercury, selenium, arsenic, lead in addition to green house gases which are harmful to human health and environment.

Many paints made from petroleum and heavy metals release toxic products into air. These toxic products cause a variety of health problems including heart, lungs damage, nausea and dizziness.



Key words

Natural resources, exhaustible resources, inexhaustible resources, petroleum, fractional distillation, natural gas, CNG, coke, coal gas, coal, coal tar, carbonisation, plankton, fossil fuels, petrochemicals.

What we have learnt?

- Natural resources can be classified into Exhaustible and inexhaustible resources.
- Fossil fuels are formed from the dead remains of living organism under the earth over millions of years.
- Coal, petroleum and natural gas are fossil fuels.
- Coke, coal tar and coal gas are the products of coal.
- Petroleum is formed at the bottom from the remains of tiny organism called plankton.
- Petroleum gas, Petrol, Diesel, Kerosene, paraffin wax, lubricating oil etc. are obtained by refining of petroleum.
- The natural gas is found sometimes along with petroleum and sometimes without petroleum.
- The useful substances which are obtained from petroleum and natural gas are called petrochemicals.
- Excessive use of fossil fuels causes air pollution, greenhouse effect, global warming and many health problems.
- Fossil fuel resources are very limited. We should think for the alternatives.
- Advances in science and technology have changed our lives.



Improve your learning



I. Reflections on concepts

1. Why petroleum is also called as liquid gold? (AS₁)
2. Mention the uses of petrochemical products in agriculture sector. (AS₁)
3. Explain the process of formation of petroleum in Earth. (AS₁)
4. Why should people look for alternative sources of fossil fuel? (AS₇)

II. Application of concepts

1. Name the petroleum products used for surfacing of roads. (AS₁)
2. What will happen if fossil fuels like coal and petroleum are completely exhausted? (AS₂)

3. Assume that you are a driver, what measures do you take to save petrol and diesel? (AS₇)
4. Suggest some alternative ways to save the fuel resources. (AS₇)

III. Higher Order Thinking Questions

1. How is biodiversity effected by the excessive use of fossil fuels? (AS₇)
2. "Crude oil and refined fuel when spills into the sea from tanker of ships by accident". Discuss the consequences of this on environment. (AS₇)



Multiple Choice Questions

1. Which one of the following is less polluting fuel? ()
a) Natural gas b) coal gas
c) Kerosene d) Petrol
2. The main constituent of coal is ()
a) Carbon b) Oxygen
c) Air d) Water
3. Which one of the following material is used for making shoe polish? ()
a) Paraffinwax b) Petrol
c) Diesel d) Lubricating oil
4. Which of the following is not a fossil fuel? ()
a) Coal b) Petroleum
c) Charcoal d) Natural gas
5. Which of the following is known as liquid gold? ()
a) Kerosene b) Diesel
c) Petroleum d) Paraffinwax



Experiments

1. Conduct an experiment to show that when we heat high quality coal, a gas evolves which can burn.



Project works

1. Burning fuels releases carbon di oxide , a green house gas, which causes climate changes and leads to global warming. Collect information about this through newspapers, magazines etc. and prepare report.
2. Compare a CNG run vehicle with that of a diesel run vehicles respect to pollutants released, level of pollution and cost of fuel.

Prepare a report on your findings.

Name of the fuel	Cost of the fuel as on today	Pollutants liberated
Diesel/Petrol.		
CNG		

3. Choose five families of your neighbourhood, collect the information about the measures that they adopt to conserve energy resources in transport and cooking.

Make a report on your observation.

Name of the Head of the family	Number of members in family	Number of vehicles using	Amount spent for Fuel in one month	Amount spent for Cooking purpose



We use different kinds of materials as fuels for various purposes at home. You might have observed or heard about how people used to burn wood, coal, cakes of cow dung, kerosene etc., for cooking food at home! Blacksmiths in villages also use them for heating metals. Both in urban and rural areas, now a day's, LPG is used as fuel for cooking the food. We use the light from the burning candle or kerosene lamp, when there is no supply of electricity. You might have also observed burning of a candle or coal. What difference do you notice in the burning process?

- Why does candle give flame when it is burnt but why does coal burn without emitting a flame ?
- Do all fuels produce same amount of heat when they are burnt?
- What do we need to burn a material?
- Have you ever tried burning a piece of paper or wood or coal, a small rock or a pebble?
- Do all of them burn?

Let us do an activity to know which of these materials burn and which do not.

Activity-1

Do all materials burn ?

You will need a pair of tongs, some metal or clay dishes and a candle or a spirit lamp.

Using tongs, pick up a small piece of paper and bring it close to the lighted spirit lamp and keep it on flame as shown in figure-1.

Record your observation in table 1.

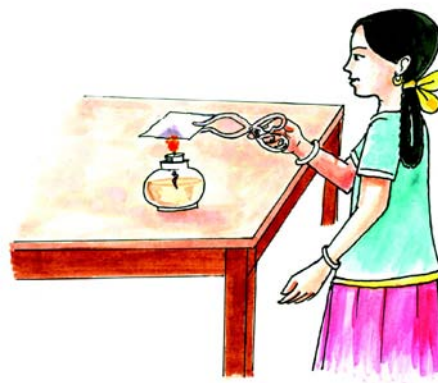

Fig-1

Carry out this experiment with a piece of charcoal, magnesium ribbon, straw, cotton cloth, nylon cloth, dry wood, pebble, wax, plastic piece etc. Record your observations.

Table 1

S.No.	Name of the material burnt	How does it burn		
		Burns immediately	Burns slowly	Does not burn
1	Magnesium ribbon		✓	
2	Pebble			✓
3	Petrol			
4				
5.				

You can also try to burn liquids.

Take 2ml of water in small plate. Bring lighted stick near to water in the plate as shown in figure 2.

- What do you observe in your attempt of burning water?
- Is there any difference in flame of lighted stick?
- What happened to the lighted stick when it is brought closer to water in the plate?

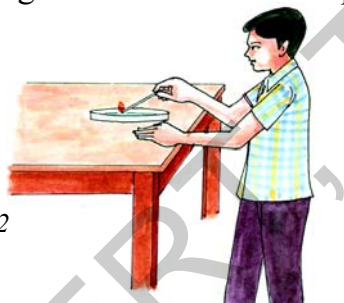

Fig- 2

Carry out this activity using coconut oil, mustard oil, kerosene, spirit, petrol etc. (sticks should be long enough to prevent any fire accident if the material catches fire)

Record your observation in table 1.

- What can we conclude from this activity?

We can conclude **that some materials burn and others don't**. In the above activity you observed that when materials burn in air, heat and light are produced.

A chemical process in which a material reacts with oxygen present in the air to generate heat is called **combustion**. The materials which burn when brought near a flame are **combustible** materials. Some of them can also be used as fuels. The materials which do not burn are called **non-combustible** materials.

- Which of the material in the above activity are combustible?



Think and discuss

- Why some material burn and why some do not? Give reasons.
- Why some materials which do not burn at normal temperature burn at higher temperatures?

8.1 What is needed for the process of combustion?

We know that we need a match stick or a lighter to burn a material.

- How will you prove that air is needed to burn a material?
- Can we burn a material in the absence of air?

Activity-2

Testing the necessity of air for burning

Take a small burning candle and put it on a table. Invert a glass tumbler over it. The candle continues to burn for some time. Then flickers and finally flame goes off. (See figure 3)

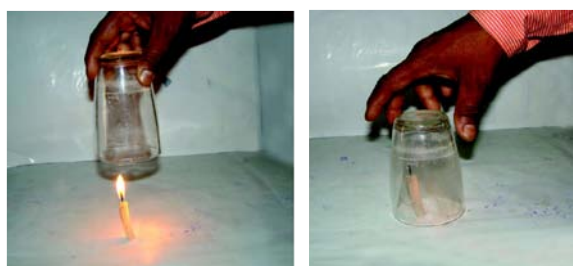

Fig-3

Remove the tumbler and again light the candle. Put the tumbler back over the candle. When the candle flame begins to flicker, remove the tumbler. What happens to the candle? Notice carefully.

We find that putting the glass tumbler over the candle cuts off the supply of air and the candle flame goes off.

This experiment proves that air is needed to burn a material. Some other experiments need to be conducted to prove that the oxygen present in air supports the combustion.



Think and discuss

If you lift the glass tumbler which is placed over a burning candle to 1cm height what happens? Why?

We can carry out an experiment to demonstrate that oxygen helps in burning.



Lab Activity

Aim: To prove that oxygen helps in burning

Material required: Test tube, test tube holder, spirit lamp, match box, incense stick (agarbatti), potassium permanganate crystals.

Procedure

Light an incense stick (*agarbatti*), and let it burn for 10 s, then put out the flame and keep it aside. (The incense stick should have a burning stub)

Take potassium permanganate in a test tube. Hold the test tube with a test tube holder and heat it over the flame of a spirit lamp. Oxygen is released on heating of potassium permanganate.

Insert the agarbatti with the burning stub, into the test tube as shown in figure-4.

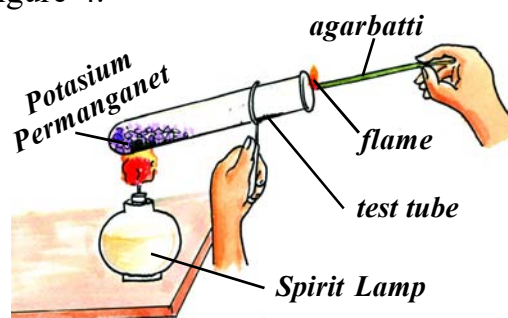

Fig-4

Observations:

- How does the scented stick start burning?
- Why does it not catch fire again when it is kept aside in air after putting its flame off?

You observe that the stick burns with a flame. Here the oxygen supports combustion by helping the agarbatti to burn with a bright flame.



Think and discuss

- How do you say that the gas released in the above experiment is oxygen?
- Can we replace potassium permanganate with any other substance to release oxygen?
- Is there any other procedure to prove that oxygen is needed for burning?

A few more examples of combustion are given below. Can you explain the reasons for the changes taking place?

- A slow fire bursts into a flame when air is blown on it, but a candle burning with flame goes off when air is blown on it. Why?
- If a large quantity of dry grass is set on fire in forests then it is very difficult to put off the fire. Why?
- When an object catches fire, the fire is put off by covering with sand or a blanket. Why?

The examples and activities discussed above shows that combustion takes place only in the presence of air.

We know that some materials catch fire as soon as they are brought near a flame, but some materials take a long time to start burning though they are kept near the flame.

- What could be the reason for the difference in burning among combustible materials?

Let us explore this in the following activities.

8.2 Ignition Temperature

In activity 1, a candle is used to burn a piece of paper. Can we burn paper without the help of flame?

Activity-3

Burning a paper with sun rays

On a sunny day, go out and focus the sun rays on a piece of paper using a magnifying lens as shown in figure-5. Touch the spot after some time. How do you feel?



Fig-5

You must have heard about people in ancient times rubbing pieces of stones together to produce sparks. Have you tried it? Rub two stones hard together and touch them. What do you feel?

Now recall some of your experiences:

- Does a matchstick burn by itself?
- Why do we rub the match stick on the side of the match box to burn it?
- Can you burn a piece of wood by bringing it close to a lighted matchstick?
- Why do we use paper or kerosene oil to start fire in wood or coal?

On the basis of above observations and previous experiences, we can conclude that a combustible substance has to be initially heated to catch fire or burn. The lowest temperature at which a substance catches fire is called its **ignition temperature**. When a substance starts burning heat is produced and it helps to burn the substance continuously. The ignition temperature is different for different substances.

The ignition temperature of a substance decides quickness of catching fire.

The substances which have very low ignition temperature and easily catch fire are called **Inflammable Substances**. Examples of inflammable substances are petrol, alcohol, liquified petroleum gas (LPG) etc.,

- Can you make a list of some more inflammable substances?

Activity - 4

Understanding ignition temperature

Take two small paper cups. Pour water in one of the cups. Put the two cups on different tripod stands and heat both of them using same size candle as shown in the figure-6.

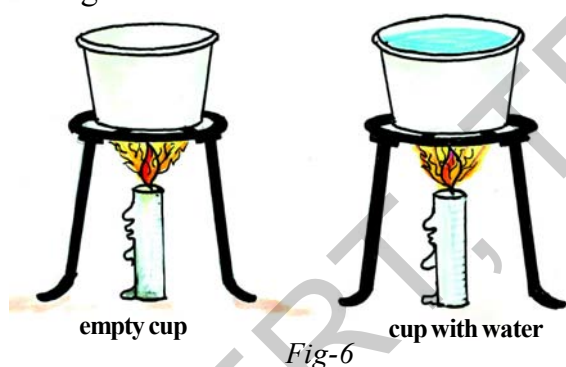

- Which cup burns quickly?
- Does the water in the cup become hot? Why?

Explain why one cup burns quickly but the other does not, on the basis of ignition temperature. When heat is supplied to cups, the heat received by second cup is transferred to water in it. The water in this cup prevents the paper to reach its ignition temperature and hence it does not burn.

- When does the second cup start burning? Make a guess and discuss with your teacher.

8.3 Types of Combustion

During summer time, dry grass catches fire on its own in the forests. It may spread to the trees and very soon the whole forest will be on fire. It is very difficult to control such forest fires.

If the head of a match stick is rubbed on the side of a match box, it starts burning.

- What makes match sticks to catch fire?

A mixture of antimony trisulphide, potassium chlorate and white phosphorus with some glue and starch was applied on the head of a match stick made of suitable wood. When it struck against a rough surface white phosphorus got ignited due to the heat of friction. This starts the combustion of the match stick. However, white phosphorus proved to be dangerous both for the workers involved in the manufacturing of match boxes and for the users.

These days the head of the safety match stick contains only antimony trisulphide and potassium chlorate. The rubbing surface has powdered glass and a little red phosphorus (which is much less dangerous). When the match stick is struck against the rubbing surface, some red phosphorus gets converted into white phosphorus. This immediately reacts with potassium chlorate in the matchstick head to produce enough heat to ignite antimony trisulphide and start the combustion.

The type of combustion in which material suddenly burns into flames without the application of any external agent is called **spontaneous combustion**.

Turn on the knob of the gas stove and bring a burning match stick or a gas lighter near it. The gas burns rapidly and produces heat and light. Such combustion is known as **rapid combustion**. Materials such as spirit, petrol and camphor burn even with a spark from a gas lighter.



Do you know?

1. You might have noticed words written as **highly inflammable** on petrol tankers. This is a warning to the public to keep flame away from the inflammable material.

2. We generally enjoy sound and light from fire works on festival days. When a cracker is ignited a sudden reaction takes place with the evolution of heat, light and sound. A large amount of gas is also liberated in this reaction. Such a reaction is called **explosion**. Explosions can also take place if pressure is applied on the crackers.



Think and discuss

- Why is phosphorus preserved in water? (Hint: think about the role of ignition temperature in combustion)
- Why Kerosene stoves and Bunsen burners have small holes in them? (Hint; Think about the role of air combustion)
- It is hard to ignite match stick in rainy days. Why?

8.4 Fuels

We know that combustion gives heat and light. The sources of heat for domestic, automobile and industrial purposes are mainly wood, charcoal, petrol, kerosene, LPG, CNG etc. These substances are fuels. In the previous chapter, we studied about the fossil fuels and their use in various ways. We not only use fossil fuels but also other kinds of fuels for different purposes at home, in automobiles and in industries. Tabulate different fuels that are used for !

Domestic purpose	Transportation purpose	Industrial purpose

Classify the above fuels into solid, liquid, gases and write them in table-2.

Table - 2

Solid	Liquid	Gas

Look at the fuels in the table-2.

- Can you decide the best fuel among them?
- What is the criteria to decide a best fuel? Discuss with your friends.

Deciding the best fuel depends upon the purpose of its use. A best fuel for cooking may not be a best fuel for running an automobile.

In general, there are several factors that have to be kept in mind while choosing a fuel, like purpose of use, fuel efficiency and availability, reasonable price, easy to handle and safe to store, easy to ignite and put off etc. The fuel should also burn at a moderate rate and cause less pollution. In addition, it should have a high calorific value.

- What is calorific value ?

Suppose 1 kg of coal and 1 kg of cow dung are burnt. Which one produces more heat? Different substances produce different amounts of heat on burning. Heat is measured in **kilo joules**. **Calorific value** of a fuel is the amount of heat energy produced on complete combustion of 1 kg of that fuel. It is measured in **kilo joules/kilogram** (kJ / kg).

 Do you know?	
Fuel	Calorific value (kJ/kg)
Cow dung	6000-8000
Wood	17000-22000
Coal	25000-33000
Petrol	45000
Kerosene	45000
Diesel	45000
CNG	50000
LPG	55000
Biogas	35000-40000
Hydrogen	150000

8.5 Fire control

You must have seen or heard about fire breaking out in houses, shops, factories, etc.

- How can we put off the fire if it breaks out ?



We use many methods to extinguish a fire. But they all follow one principle. That is the *principle of elimination of factors which support the combustion*.

Let us recall the factors which support the combustion:

- Presence of a combustible material or the fuel
- Supply of air or oxygen
- Temperature more than the ignition temperature.

So, elimination of any of the three factors will help in controlling the fire. Let us see some examples.

Example:

If a fire breaks out in a house or in any business establishment the fire brigade will immediately put off the electric mains and then start spraying water on the fire.

- Why the fire brigade start the work by putting off the electric mains?
- How water helps in eliminating the factors, which support the combustion?

Initially, the water spray cools the combustible material below its ignition temperature. This prevents the fire from spreading.

Then the heat turns the water into vapours which surround the burning material and prevent supply of oxygen to the burning materials. So, the fire is extinguished.

The most common fire extinguisher is water. But water works only when things like wood cloth and paper are on fire. If electrical equipment is on fire water may conduct electricity and harm those trying to douse the fire.

Water is also not suitable for fires involving oil and petrol, because water is heavier than the oil, it sinks below the oil and oil keeps burning on the top.

Since it is difficult to remove the combustible material from a fire, cutting of air supply and lowering the temperature are better methods.

In cases where water cannot be used, carbon dioxide gas is the best choice used which is heavier than oxygen. It can be stored as a liquid in cylinders under high pressure. When released from the cylinder, it expands and brings down the temperature. It also covers the fire like a blanket. Since the contact between the fuel and oxygen is cut off, the fire is controlled. That is why it is an excellent fire extinguisher. The added advantage of carbon dioxide is that in most cases it does not harm the electrical equipment. It is mandatory for offices, educational institutions and multistoried buildings to install fire extinguishers.

8.6 Flame

Activity - 5

Observing the behaviour of different solid fuels

Collect some fuels like candle, coal, domestic gas, charcoal, magnesium ribbon, wood, cakes of cow-dung, camphor, wick of the oil lamp, wick of kerosene stove, etc. Burn each of them one by one with the help of spirit lamp and note the time they take to catch fire. Also observe how do they burn?

- Do all of them burn in the same manner? What difference do you notice?
- Do all of them form a flame while they are burning?

Record your observation in the table-3.

Table - 3

Material	Time Taken to burn	Forms flame	Does not form flame
Candle			
Magnesium			
Cow dung cake			
Charcoal			
Domestic gas			
Camphor			
Wick of Kerosene stove			

You may observe that a candle burns with flame where as charcoal does not. Some materials burn with flame, some do not.

Kerosene oil and molten wax rise through the wick become gas and form flames. But charcoal cannot be vapourised. So it does not produce a flame. A fuel catches fire immediately if it is in the form of gas. Cooking gas catches fire immediately. Spirit and petrol turn into gas at room temperature. Hence, they catch fire quickly.



Think and discuss

A wax candle burns with a yellow flame. The domestic gas burns with a blue flame. Why?

8.6.1 Structure of a flame

Activity-6

Observing the structure of the flame



Light a wax candle and watch the flame. Carefully note the different coloured zones in the flame. How many colours are there in the flame?

Starting from the base of the flame, how many flame zones do you observe? What is the colour of the outer most zone of the flame?

Observe the innermost zone which is dark. What do you observe there? Is there combustion takes place? In this zone wax gets vapourized. This is a dark zone. See figure 7.

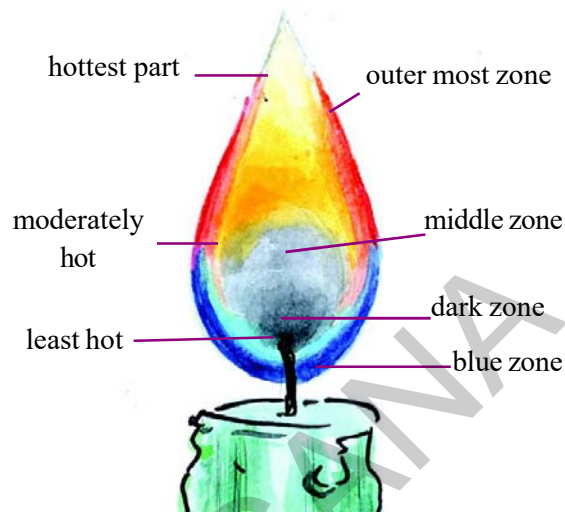

Fig-7

Observe near the base of the flame. Vapourized wax gets completely oxidized and burns with a blue flame. It is blue zone.



Do you know?

A candle is mainly a source of light but heat is also released. A candle is made of wax in which a thick thread is inserted. Wax in the candle melts when it is lighted by a match stick. A little of the wax forms vapour. This vapour combines with oxygen in the air to form flame. The heat of the flame melts more wax from the top of the candle. The liquid wax moves upward through the thread. It also changes to vapour when it reaches the top of the wick and burns with the flame.

Activity-7

Observing the different zones of candle flame

Light a candle. Hold a glass tube with a pair of tongs and introduce its one end in the dark zone of a non flickering candle flame. Keep lighted match stick near the other end of the glass tube as shown in figure-8. What do you observe? Do you see a flame? If so what is it that produces a flame? Notice that the wax near the heated wick melts quickly.

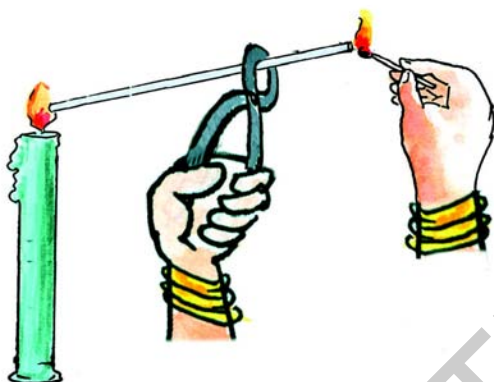

Fig-8

When the candle's flame is steady, introduce a clean glass slide into the luminous zone (yellow zone) of the flame and hold for 10 seconds as shown in figure-9. What do you observe?

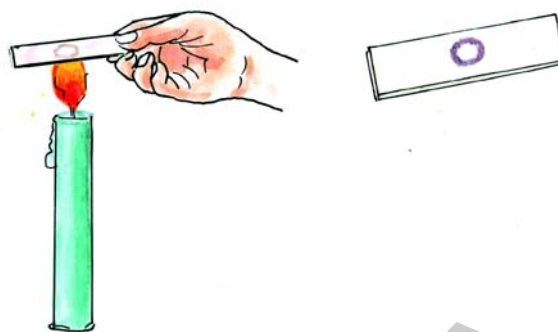

Fig-9

A blackish circular ring is formed on the glass slide. What is it? It indicates the deposition of un-burnt carbon particles present in the luminous zone of the flame. Incomplete combustion takes place in this zone.

Hold a thin long copper wire just inside the flame for about half a minute as shown in figure-10. What do you observe? The copper wire just outside the flame gets red hot. It indicates that the non-luminous zone of the flame has high temperature. It is the hottest part of the flame. It is blue in colour and complete combustion takes place due to good supply of oxygen.

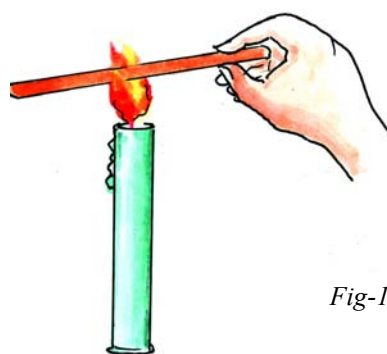

Fig-10



Key words

Combustion, combustible and non - combustible materials, ignition temperature, inflammable material, spontaneous combustion, rapid combustion, explosion, fuels, calorific value.

What we have learnt?

- Burning a material in the presence of air (oxygen) is called combustion.
- Oxygen or air is needed for combustion to take place.
- The lowest temperature at which a substance catches fire is called its ignition temperature.
- Without any external agent, a material burning suddenly is called spontaneous combustion.
- The type of combustion in which material burns rapidly and produces heat and light is called rapid combustion.
- The amount of heat energy produced on complete combustion of 1 kg of fuel is called the calorific value of that fuel.
- Combustion does not take place in the dark zone of the candle flame.
- In the blue zone of the candle flame, vaporized wax burns completely due to good supply of oxygen.



Improve your learning



I. Reflections on Concepts

1. Give four examples of combustible materials. (AS₁)
2. Why should not we store spirit or petrol near our living place? (AS₁)
3. The oil fires should not be sprayed with water. Why? (AS₂)
4. Water is not used to control fires involving electrical equipment. Why? (AS₁)

II. Application of concepts

1. What precautions are to be taken while pouring water on fire? (AS₁)
2. Give an example of a good fuel. How do you choose that fuel? Explain. (AS₁)
3. It is difficult to burn a heap of green leaves but not a heap of dry leaves. Explain why? (AS₁)
4. Where do you find spontaneous combustion, rapid combustion in your daily life? (AS₇)



Project works

1. List out the different fuels that are used in your daily life and classify them into solids, liquids and gases.
2. Collect information available on different fuels. Find out the cost per kg. Compare the cost with calorific value. Prepare report on that.
3. Collect the information about annual fuel consumption in different parts of the world. How many years more the fossil fuels last? Make a poster with this information and issue an appeal to save fuel.

Sometimes we read in newspapers about farmers getting electric shocks while starting water pumps of the wells, especially because of contacts made with switches or starters by wet hands. Do you know the reason behind getting electric shock while working with wet hands?

Our elders caution us about touching electric heater immersed in water. Why do they instruct us to stay away from it? How does the electric current flow through water?

In the earlier class you have learnt that electric current can pass easily through metals like copper, aluminium, etc. Do you recall some other materials which conduct electric current? Let us revise the activity and do it now.

Activity-1

Testing the material to know which allows electric current to pass through it

Take a torch bulb or LED (Light Emitting Diode), a dry cell, Wooden sheet, a key (safety pin), two drawing pins and pieces of copper wire to make a circuit.



Set up the electric circuit as shown in the figure-1.

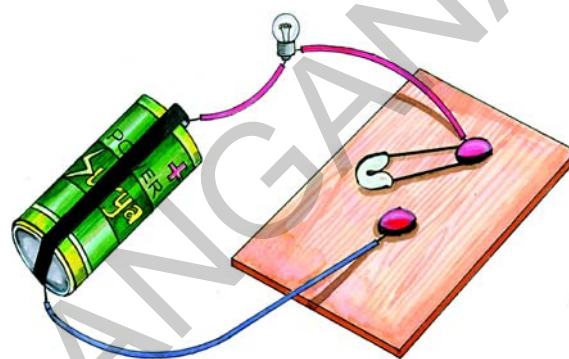

Fig-1 : Testing conductivity of material

Place the key between drawing pin (Such that key connects two pins). The bulb begins to glow as soon as the key touches the drawing pin. Now replace the key by a nail. Does the bulb glow?

Repeat the activity using different types of materials instead of the nail, say a strip of paper, a piece of chalk, a drinking straw, a piece of plastic, a paper clip, a rubber eraser, pencil graphite etc. Note in each case whether the bulb glows or not and enter your observations in Table-1.

Table 1

S.No.	Object	Material	Bulb glows Yes/No	Conductor Yes/ No
1	Nail	Iron	Yes	Yes
2	Eraser	Rubber	No	No

Whenever the bulb glows, remove the material. It avoids the early discharge of dry cell.

In the above activity, we observed that some materials allow electric current to pass through them. We call them as good conductors of electricity.

In general, all metals are good conductors of electricity. On the other hand, the materials that do not allow current to pass through them are called bad or poor conductors of electricity.



Think and discuss

Why some material allows electric current to pass through them and why some do not?

Electric conductivity is a property of any given material. We can say that a material has good electrical conductivity if it allows electric current to pass through it easily.

9.1 Electrical conductivity of liquids

In the activity-1, we have tested conductivity of objects like nail, paper strip, chalk, etc. All of these are solids. What about liquids? Do the liquids allow electric current to pass through them?

Let us do another activity to find out.

Activity-2

Testing the electric conductivity of liquids

Take a LED, dry cell, metal pins, rubber cap of injection bottle and copper wires for making connections. Set up an electric circuit as shown in the figure-2.

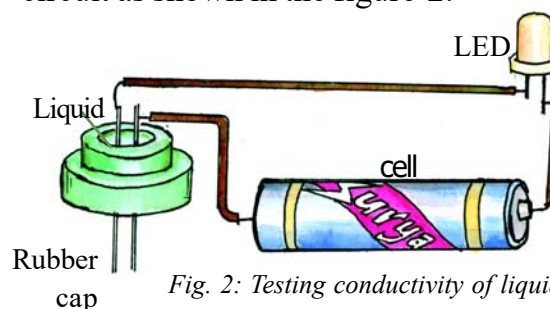

Fig. 2: Testing conductivity of liquids

See that the two metal pins, pass through the cap should have a very small gap (around 2 mm) between them so that the pins are fairly closer but not touching each other. The LED should not glow when pins are separated by the small distance.

Now, join the free ends of the pins together by pressing them for a moment and make sure that the LED glows. Release the pins, they get separated and LED should not glow. This becomes our tester. We will use this tester to check the conductivity of liquids.

Fill the rubber cap with different liquids, one after another and in each case, check whether the LED glows or not. Start with distilled water (you can get distilled

water from battery stores or from medical shop). Pour distilled water in the rubber cap till the two metal pins come in contact with it. Check whether the LED glows or not.

Then take water that you drink in school and repeat the procedure. Do this activity with liquids like coconut oil, kerosene, lemon juice, mustard oil, sugar solution, etc. After testing each of the liquids, carefully wipe and dry the cap and the pins before filling it with the next liquid. In each case, note your observations in Table-2.

From your observations, decide which liquids are good conductors of electricity and which are poor or bad conductors and note down in Table-2.

Table 2

S.No.	Liquid	LED glows Yes/No	Good conductors/ poor or bad conductors
1	Distilled Water	No	bad conductor
2	Drinking water	Yes	good conductor
3	Coconut oil		
4	Lemon juice		
5	Vinegar		
6	Kerosene		
7	Vegetable Oil		
8	Sugar solution		
9			
10			

Let us think about the above table-2.

- Why doesn't the LED glow in all the cases? Or why doesn't the LED remain off in all the cases?

In activity 1, we saw that when current flows through the object inserted in the gap, the bulb glows. Similarly, we can see that when the liquid between the two pins of the tester allows electric current to pass through, the circuit is completed (closed) and the LED glows. Then we say, the liquid is a good conductor.

On the other hand, when the liquid does not allow the current to pass through, the circuit is incomplete (Open) and the LED does not glow. Then we say the liquid is a bad conductor.

List out the good conductors from table-2.

In the above activity, you may have observed that in all those cases where the LED glows, its brightness (intensity) is not the same. Sometimes it may be brighter and sometimes it may be relatively dimmer. Why is that so?

The intensity of the glow of the LED depends on the flow of electric current through the circuit. Although a liquid may be a conductor, it may not allow current through it as easily as a metal does.

As a result, although the circuit is completed and the LED glows, due to weak current in cases of some of the liquids, the intensity of glow would be lower compared to other liquids.



Do you know?

Why do we use LED in the tester instead of a bulb?

LED glows even when a very weak current is passing through the circuit. Thus, it helps in testing flow of electricity in conductors when meager current is passing through the circuit.

Since LEDs glow even with a very little current passing through them, they are used as 'indicators' in electrical appliances like mobile phones, televisions, transformers, etc. to indicate whether the device is working or not.

There are two wires called leads attached to an LED. One lead is slightly longer than the other. See figure-3.



Fig. 3 (LED)

While connecting to the LED to the circuit, the longer lead is always connected to positive terminal of the battery and the short lead is connected to the negative terminal of the battery.

9.1.1 When do liquids conduct electricity?

In the activity-2 we observed that distilled water does not conduct electricity. Can we make poor conductors like distilled water to conduct electricity? Let us try it out.

Activity-3

Electric conductivity of electrolyte

Take same amount of distilled water in three different containers. Dissolve small

quantity of common salt in the water of first container. Dissolve the Copper Sulphate (Mylatuttam), lemon juice in 2nd and 3rd containers respectively.

Use the tester that we used in activit-2, and repeat the activity-2. Note your observations in Table-3. (Caution: Wash and wipe the pins of tester to dry after testing with each liquid.)

Table 3

S.No.	Material	Does the LED glow? Yes/No	Good conductor/ bad or poor conductor
1	Distilled water	No	Bad conductor
2	Dist. Water + salt		
3	Dist. Water + copper sulphate		
4	Dist. Water + lemon juice		
5	Dist. Water + detergent		

From the above observations, what can we infer? Distilled water does not allow the electric current to pass. Water in its pure (distilled) form is a bad conductor of electricity. But when water contains salts or acids, it allows passage of electric current and turns into a good conductor of electricity.

The water that we get from sources such as taps, hand pumps, wells and ponds is not pure like distilled water. It contains some salts and minerals dissolved in it. Some of these minerals are useful for our health. This water is a good conductor of electricity.

On the other hand distilled water is free of all salts, minerals, acids, etc. and is a poor conductor of electricity.

- Do you now understand why you are advised not to touch electric appliances with wet hands?

Water with salts is a good conductor of electricity and the current flowing through house hold electric appliances is very high. Therefore, we should never touch the electrical appliances with wet hands.

Like water in the above activity, most liquids that conduct electricity are

9.1.2 Chemical effect of electric current

If solutions of different salts and acids conduct electricity, what about vegetables and fruits? Are these electric conductors? Let us try to find that out.

Activity-4

Testing the effect of electric current on potato

Take a potato. Cut into two halves and take one half of it. Construct tester with LED bulb, insert two copper wires of the tester into the potato leaving some distance (around 1 cm) between them. as shown in figure-4.

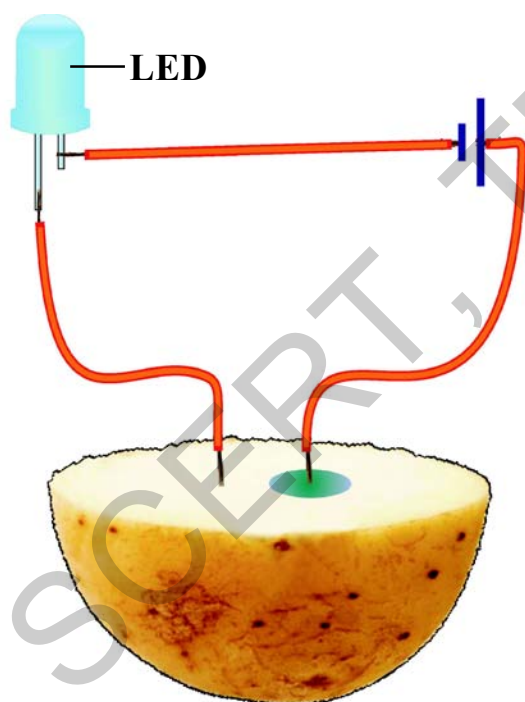

Fig. 4

- Does the LED glow?

Leave the inserted wires for 20-30 minutes.

- What do you observe on the surface of the potato?

A greenish blue spot is seen on the potato around the wire connected to the positive terminal of the battery. But no such spot is seen around the other wire connected to the negative terminal. This greenish spot is due to chemical change in the potato.

- What could be the cause behind this change?
- Will other vegetables also show such an effect?

Try it out with vegetables like carrot, beetroot, cucumber, raddish, brinjal, sweet-potato, etc.



Think and discuss

If a battery is packed in a box and if only two wires from two terminals are given out, how can we decide the positive and negative terminal of the battery?

9.2 Electrolytic cell

In all the above activities, the battery we have used is made up of dry cells. In lower classes you have studied about dry cell.

- Can you produce electric current in another way?
- Do you know, how was the first cell made?



Do you know?

How the first cell was made?

People in Europe began experimenting with electricity around 400 years ago. They generated electricity in different ways and conducted various experiments. However, they faced one major problem which prevented them from understanding electricity in depth. They did not have a stable and permanent source of electricity. This may sound like a minor problem today, but it took scientists nearly 200 years to find a solution.



That solution came in the year 1780. And it came almost by chance. A biologist named Luigi Galvani from Bologna, Italy, once saw a frog's leg hung from a copper hook twitching violently when it touched another metal. It seemed as if the frog's leg had suddenly come to life.

Galvani did many more experiments with the legs of dead frogs. He finally came to the conclusion that frog's legs twitched every time electricity flowed through them. Galvani thought he had discovered living or biological electricity. He presented his theory to the world, saying that all living beings contained electricity and it was this electricity that was their main source of life.

Galvani's experiments took the whole of Europe by storm. Many scientists began performing similar experiments with various species of animals. Among them was Alessandro Volta of Italy. He too performed experiments with frog's legs. However, he discovered that if a frog's leg hung from an iron hook is touched with another iron rod, it does not twitch. Volta was a bit puzzled.

If the reaction in a frog's leg is due to the electricity in its body, why are two different metals required to make it twitch, he wondered? After a lot of thinking he arrived at the conclusion that electricity does flow through the frog's leg when two different metals touch it. However, this electricity is not contained in the leg of the frog but is generated by some other process.

Volta repeated his experiment using different liquids instead of frog's legs. He found that it did not require an animal's body to generate electricity. It is possible to generate electricity if two different metals are placed in some liquids.

These experiments showed the way to a steady source of electricity. Volta made his first cell in 1800 using zinc and copper plates dipped in sulphuric acid. His discovery made him famous in the realm of science. The cell he made is called a Volta cell in his honour. The word voltage is also derived from his name.

Let us make a cell with the same metals and chemicals used by Volta.

Activity-5

Make your own cell

Collect two injection bottles. Cut two 5 cm-long bits of thick copper wire. Use sandpaper to scrape about 1 cm of the coating from both ends of the wires.

Break open an exhausted dry cell and remove its outer metal covering (made of zinc). Cut two 2 mm-wide and 5 cm-long strips from this zinc plate. Insert the copper wires and zinc strips into the rubber caps of the injection bottles as shown in figure 5. Ensure that the copper wire and zinc strips do not touch each other.

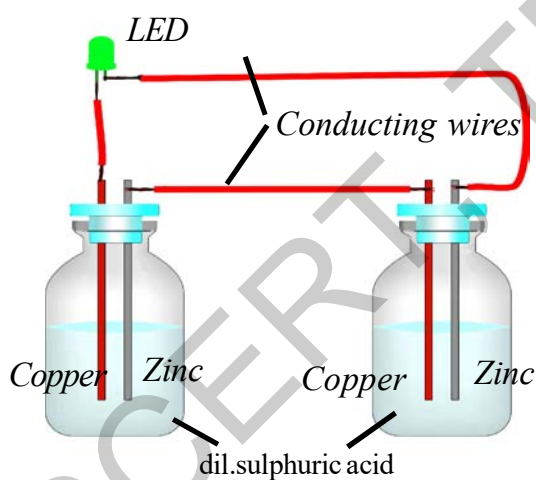

Fig. 5

Now take a wire and connect the copper wire of one bottle with the zinc plate of the other bottle. Fill both bottles with dilute Sulphuric acid carefully and fix the caps in which the copper wires and zinc strips are inserted. Your cell is ready.

How do you test it?

Take an LED. Attach two wires to its two terminals. Touch the wire from one terminal to the zinc plate and the wire from the other terminal to the copper wire. Did the LED light up? If not, change the connections vice-versa. Did the LED glow?

Repeat the above activity using lemon juice, tamarind juice and tomato juice one by one instead of sulphuric acid to make your cells.

- What other liquids can be used to make the cell?
- Will detergent solution be useful? Find it out yourself.
- How does the above cell function?

After a few seconds of immersion of zinc and copper wires into dilute sulphuric acid, zinc slowly begins to dissolve in the sulphuric acid. We can see bubbles forming on the copper rod.

The current is passed from copper rod to zinc rod. These rods are known as **electrodes** and dilute sulphuric acid is known as **electrolyte**.

Here the chemical energy is converted into electric energy by “electrolysis method”.

Can you compare this cell with dry Cell?

Which is good one? Why?



Think and discuss

What is electrolysis?

Discuss with your teacher or collect the information about electrolysis method from your school library books.

9.3 Electroplating

Can you list some objects around you that keep shining? For example, the clip of your writing pad or rim of a newly bought bicycle.



If these objects are scratched deliberately or accidentally, their shine diminishes. Scratching of such objects removes some coating from their surface and we can see a relatively dull surface below the coating. Safety pins, when they are new, shine brightly. However, with repeated use, they lose the brightness of shining. Repeated handling makes the coating of the pins wear off and the non-shiny metal beneath is exposed.

In the above examples, the material underneath contains a coating of another metal. How is this achieved? How is the shining metal coated on the dull object?

Let us try doing it ourselves.



Lab Activity

Aim: Coating an iron key with copper by electroplating method.

Required material: Copper plate of size 2 cm x 5 cm, crystals of copper sulphate (blue vitriol), a key made by iron, glass

beaker, water, sulphuric acid, Battery and some connecting copper wires. (You may take a thick copper wire and hammer it to flatten it instead of the above mentioned copper plate.)

Procedure:

Dissolve crystals of copper sulphate in pure water to prepare concentrated solution (deep blue in colour). Pour the solution in a beaker and add a few drops of dilute sulphuric acid to it. (Acid helps in increasing the conductivity of electrolyte.)

Tie one end of a copper wire to the iron object (key). Connect its other end to the negative terminal of a battery. Take another copper wire and tie its one end to the copper plate. Connect its other end to a switch and then to the positive terminal of the battery. Copper plate and key should be suspended in the solution as shown in the figure-6.

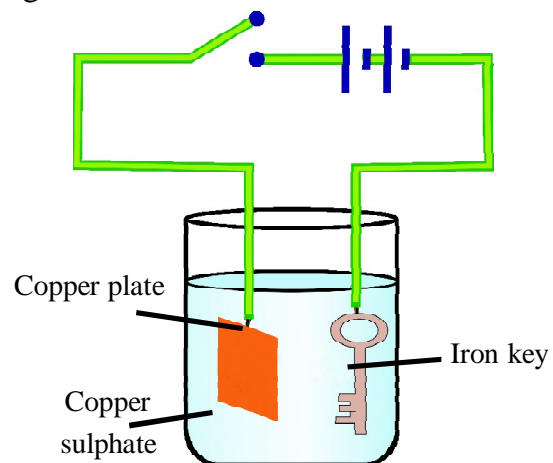

Fig. 6: Electro plating

Care should be taken that the key and plate do not touch each other and are a little away from one another. Put the switch on for about 10 minutes. After 10 minutes Switch off the circuit and take the iron key out.

Observations :

- Does the iron key get coated with a shiny, brown colour?
- What is the colour due to?
- What will happen if you interchange the battery terminals?
- Why does copper get deposited on the iron key?

When electric current is passed through the copper sulphate solution, in which the copper sulphate is present in the form of copper and sulphate ions, the free copper ions are drawn to the electrode (here iron key) connected to the negative terminal of the battery and deposited on iron key.

The process of coating one metal with another metal is known as electroplating.

If the key is to be coated with zinc or aluminium instead of copper, what changes do we need to make in the above experiment?

In electroplating, an inferior metal (metals which are effected by the atmospheric humidity, carbon dioxide, etc.) is coated with a superior metal (metals which are not effected by the humidity or oxygen).

The following are the requirements for fine coating.

- a) The object to be electroplated should be free from greasy matter.
- b) The surface of the article should be rough so that the metal deposited sticks permanently.
- c) The concentration of the electrolyte should be so adjusted as to get smooth coating.
- d) Current must be the same throughout.

9.3.1 Electroplating – uses

Electroplating is widely used in industry for coating metal objects with a thin layer of different metals.

For example, metals like iron which are easily corroded by atmospheric air, moisture and oxygen are coated with deposits of nickel or chromium which are most resistant to such corrosion by electroplating method. Machinery parts are often chromium plated to protect them from corrosion and at the same time to give them good polish. (see Figure 7)



Fig. 7

Sometimes, electroplating is done with a view to repairing worn out parts of machinery. In such cases the suitable metal is deposited on the affected parts of the machinery by electroplating method.

Electroplating is also used in ornamentation and decoration. For example several articles made of copper or its alloys, such as table wares, decoration pieces are coated with silver or gold. (see Figure 8)



Fig. 8

In general the processed food items are preserved in tin coated iron cans. Tin is less reactive to the food than iron. So the cans are made by electroplating tin on iron. (see Figure 9)

When iron is coated with zinc metal, iron becomes more resistive to corrosion and formation of rust. So, zinc coated iron is used for bridges and in automobiles.



Fig. 9



Key words

Good conductors, Poor conductors, Electrodes, Electrolyte, Electrolysis, Electroplating



What we have learnt?

- Some liquids also conduct electricity as some solids do.
- Some liquids are good conductors of electricity and some are poor conductors.
- Distilled water does not allow the current to pass through it.
- Most Liquids that conduct electricity are solutions of acids, bases and salts.
- Electrolyte is a solution of a substance through which electric current can pass.
- Electroplating is possible through electrolysis.



Improve your learning

I. Refelections on concepts

1. Give examples for good solid and liquid conductors of electricity. (AS₁)
2. Give examples for poor solid conductors and liquid conductors of electricity. (AS)



3. Give two examples for electrolyte. (AS₁)
4. Draw the diagram of Electrolytic cell and explain. (AS₃)

II. Application of concepts

1. Which energy is cause for glowing of bulb in electrolytic cell? (AS₁)
2. What do you add to distilled water for making it to conduct electricity? (AS₁)

III. Higher Order Thinking Questions

1. If the key is to be coated with aluminium instead of copper, what changes do we need to make in the experiment of coating on iron key with copper? (AS₃)
2. Can plastic be coated by the process of electroplating? Why? (AS₂)



Multiple Choice Questions

1. Which of the following method is also used in ornamentation and decoration? []

a) Electro typing	b) Electro plating
c) Electro printing	d) Galvanizing
2. Pure water is []

a) Electric conductor	b) Semi conductor
c) Poor conductor	d) Resistor
3. The material which do not allow electric current to pass through it is known as []

a) Electric conductor	b) Poor conductor
c) Electric resistance	d) Semi conductor
4. Electro plating is possible through []

a) Electrolysis	b) Chemical process
c) Dissolving	d) Filtration
5. One of the following is not an electrolyte []

a) Sulphuric acid	b) Lemon juice
c) Tamarind juice	d) Detergent solution



Experiments

1. Conduct an experiment for coating on iron key with copper by electroplating method and prepare a report.
2. Conduct an experiment for testing the electric conductivity of liquids and prepare a report.
3. Conduct an experiment for testing the electric conductivity of electrolytes and prepare a report.



Project works

1. Collect the information from various sources on the applications of electroplating in daily life and prepare a report on that.
2. In many of the activities in this chapter, we have used a tester made up of LED. Can we avoid LED and use something else as a tester? Collect the information and make a model.



In the earlier classes you have learnt about winds, storms and cyclones. You have learnt that cyclones can cause a lot of damage to life and property. You also learnt that we can protect ourselves from these destructive phenomena to some extent.

In the present chapter, we shall discuss two other natural phenomena that cause destruction. These are lightning and earthquake. We shall also discuss what steps we can take to reduce the destruction caused by these phenomena.

10.1 Lightning

You might have seen sparks on an electric pole when wires become loose or when wind blows and shakes the wires. You might also have seen sparks when a plug is loosely put in its socket and the switch is put on. (*Do not try this if you have never seen such a spark.*)

Lightning is also an electric spark, but on a huge scale. In ancient times people did not understand the cause of these sparks. They were, therefore, afraid of lightning and thought that the wrath of gods or evil spirits was striking them. Now, of course, to some extent we understand reasons for lightning.

We have to take some precautions to protect ourselves from the deadly sparks of lightning.

The Sparks that the Greeks Knew About!

The ancient Greeks knew, as early as in 600 B.C. that when amber (amber is a kind of resin) was rubbed with fur, it attracted light objects such as hair.

You might have seen that when you take off woollen or polyester clothes, especially in summer season the hair on your skin stands on end.

- Why does hair get attracted towards clothes?

In 1752, Benjamin Franklin, an American scientist, showed that lightning and the spark from your clothes are essentially the same phenomena.

People before Franklin knew about the phenomena of lightning and hair getting attracted to clothes but did not have an idea that these are related. However, to realise that these two are the same phenomena but at different scales, it took about 2000 years.

Scientific discoveries are a result of hard work by many people. It can sometimes take a long time.

We shall now study some properties of electric charges. We shall also see how they are related to the lightning in the sky.

Let us perform some activities to understand the nature of electric charges. Let us recall what you might have played as a game.

When you rub a plastic scale on your dry hair, the scale can attract very small pieces of paper.

- Why is the plastic scale not able to attract pieces of paper before it gets rubbed by dry hair?

10.2 Charging by rubbing

Activity-1

Effect of rubbing

Take a used ball-pen refill and bring it near small pieces of paper. The refill should be close enough but not touch the pieces of paper. Check what happens to the paper-pieces.

Now, rub the refill vigorously with a piece of polythene. Bring it close to small pieces of paper. Note your observation. Take care that the rubbed end is not touched by your hand or with a metallic object.

Now, take a comb and move it through dry hair a few times. Take the comb near small pieces of paper and check what happens.



Fig-1

Take an inflated balloon and rub it against your clothes. Bring the balloon close to small pieces of paper.

Take a drinking-straw and rub it against a smooth wall or against your clothes, then bring it near pieces of paper.

- What do you observe?
- Are they able to attract bits of paper after being rubbed?

Repeat the activity using mentioned objects like refill, comb, drinking straw, balloon with small pieces of dry leaf, husk, etc as testing materials. Record your observations in table-1.

- What can we infer from the above activity?
- Do the objects like refill or comb attract pieces of paper only after rubbing?
- Do all objects show this property?
- Can we rub a comb against our palm and make it attract the paper bits? Try it and see.

Table-1

Object	Material used for testing	Effect before rubbing	Effect after rubbing
Refill	Bits of Paper	Paper bits remain stationary	Paper bits get attracted to the refill
	Pieces of dry leaves		
	Husk		
Comb	Bits of Paper		
	Pieces of dry leaves		
	Husk		
Balloon	Bits of Paper		
	Pieces of dry leaves		
	Husk		
Drinking Straw	Bits of Paper		
	Pieces of dry leaves		
	Husk		

Let us try to find out whether all objects show this property. We will also try to find out whether attracting paper-pieces is only due to rubbing or rubbing with specific materials.

When a plastic refill is rubbed with polythene, it acquires a small electric charge. Similarly, when a plastic comb is rubbed with dry hair, it acquires a small charge.

These objects are called charged objects. In the presence of a charged refill or plastic comb, bits of paper and hair also get charged. Let's try to charge some other objects that are familiar to you.



Lab Activity

Aim: To find the effects of charged bodies which have been rubbed by different materials.

Material required: A ball pen refill, a balloon, a comb, an eraser, a steel spoon, polythene sheet, plain paper, woollen cloth, etc.

Procedure :

Rub the above objects against materials listed in table-2. In each case, bring the rubbed object near small pieces of paper and note whether they attract pieces of paper or not. Record your observations in table-2 by writing 'yes' or 'no'.

Table-2

Object	Material used for rubbing	Whether paper pieces are attracted?
Refill	Plain Paper	
	Polythene sheet	yes
	Woollen cloth	
Inflated Ballon	Dry hair	
	Polythene sheet	
	Woollen cloth	
Comb	Plain Paper	
	Polythene sheet	
	Woollen cloth	
Eraser	Dry hair	
	Polythene sheet	
	Woollen cloth	
Steel spoon	Plain Paper	
	Polythene sheet	
	Woollen cloth	

- What do you conclude from the above table?

Some objects like refill, comb, etc when rubbed with some specific materials are able to attract light objects like bits of paper. But some objects like steel spoon do not attract pieces of paper even after rubbing.

- Why do not some materials attract pieces of paper even after rubbing?

Let us try to explore this phenomenon further.

10.3 Types of charges and their interaction

Activity-2

Understanding types of charges

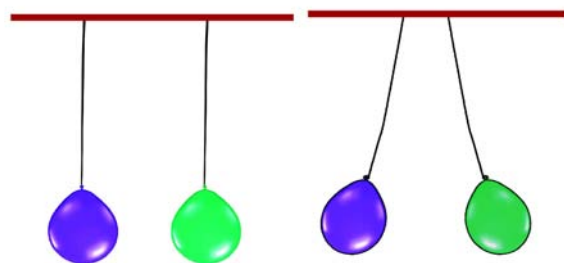

Fig-2(a)

Fig-2(b)

Take two balloons and hang them in such a way that they do not touch each other. Rub both the balloons with a woollen cloth and release them.

(Make sure that your hand doesn't touch the balloon while rubbing with woollen cloth).

- What do you observe?

Take a refill and rub it with a polythene sheet. Keep it gently in a plastic tumbler. Take another refill and also rub it with the same polythene sheet. Bring the second refill near the first one in the tumbler. Take care that you do not touch either of the rubbed portions of the refills with your hand.

- Is there any effect on the first refill in the tumbler?
- Do they attract each other or repel?

Bring two balloons rubbed with same silk cloth together. What happened?

Now, take a rubbed balloon near the rubbed refill in the tumbler (See fig-3). What happened?



Fig-3

- Do they attract each other or repel each other?

In the first two parts of the above activity, two objects that were made of the same material have brought near to each other after being rubbed with some appropriate material.

In the third part, objects made of different materials were brought near to each other after being rubbed with different material.

Let us summarise our observations carefully.

1. A balloon rubbed with woollen cloth repelled another balloon of the same type.
2. A refill rubbed with polythene repelled another refill rubbed with similar material.
3. A balloon rubbed with woollen cloth attracted by a refill rubbed with polythene sheet.

- What can we conclude from above observations?
- Does the repulsion between charged balloons indicate that they possess similar charge?
- Does the attraction between a charged balloon and a charged refill indicate that they possess different charges?
- Does this activity remind you some of experiments that you have done in 'Playing with Magnets' chapter of class 6?

We know that magnets attract objects made up of magnetic materials like Iron, Nickel, Cobalt, etc.

We also know that unlike poles of magnets (North-South or South-North) attract each other and like poles (North-North or South-South) repel each other.

- Can we say that something similar is happening in above activities?
- Does it indicate that the charge on the balloon is of a different kind from the charge on the refill!
- Can we say that there exists two kinds of charges?
- Can we also say that the charges of the same kind repel each other, while charges of different kinds attract each other?

It is a convention to call the charge acquired by a glass rod when it is rubbed with silk cloth positive and the charge acquired by the silk cloth is negative.

It is observed that when a charged glass rod is brought near to a charged plastic straw which is rubbed with polythene sheet, there is attraction between the two.

- What do you think about the kind of charge on the plastic straw?

You may guess that the plastic straw would carry a negative charge.

- Is your guess correct or wrong? Discuss with your teacher.

The electrical charges generated by rubbing are static. They do not move by themselves. When charges move, they constitute an electric current.

You studied about the current in a circuit which makes a bulb glow, or the current that makes a wire get heated in class 6 and 7.

The electric current in a circuit represents motion of charges.

Activity-3

To find the presence of charge on a body

Make a small ball of thermocol. Collect thin silver foil used to decorate sweets. Wrap this thin silver foil to cover the thermocol ball and suspend it from a stand with the help of a thread as shown in the figure-4.

Bring a glass rod which is rubbed with a silk cloth near the suspended ball. What happens? Does it get attracted towards the glass rod or move away from it?

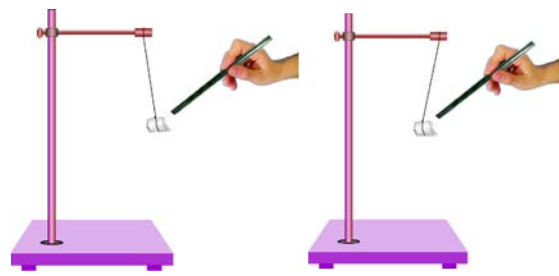

Fig-4: Testing the presence of charge

Now touch the silver foil on the thermocol ball with charged glass rod. Remove the glass rod from the ball and again rub it with silk cloth and bring it close to the suspended ball.

- What do you observe?
- Does it get attracted towards the glass rod or move away from it?

You may notice in the first instance that the thermocol ball is attracted towards the glass rod and in second instance it moves away from the glass rod.

- What could be the reason for this change in movement of the ball?

If a charged body is brought near an uncharged body it induces an opposite charge on it and it gets attracted by the body.

In the above activity when a charged body (glass rod rubbed with silk cloth) is brought near an uncharged body (thermocol) it induces an opposite charge in it and hence it gets attracted by the glass rod.

In second case (above activity) we have charged the thermocol ball by touching it with a charged glass rod. Hence when we brought the glass rod near the ball, as both of them have similar charge the ball gets repelled by the glass rod.

From the above activity we can conclude that attraction is not a sure test to know the presence of a charge on a body.

Activity-4

Transfer of charge

Take an empty jam bottle. Take a piece of cardboard slightly bigger in size than the mouth of the bottle.

Pierce a hole in it so that a metal paper clip could be inserted. Open out paper clip as shown in the fig-5

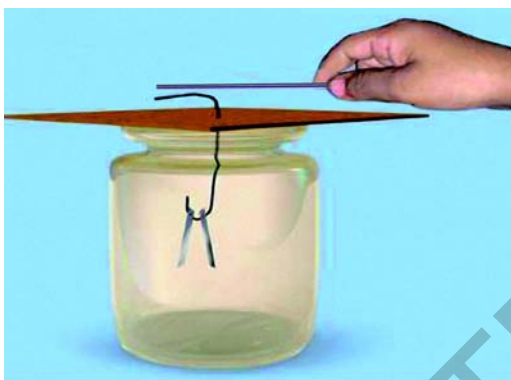

Fig-5

Cut two strips of aluminium foil about $4\text{ cm} \times 1\text{ cm}$ each and hang them on the paper clip. Insert the paper clip having the strips of aluminium foil in to the cardboard lid so that it is perpendicular to it as shown in the fig-5.

Charge a refill and make it touch the end of the paper clip. Observe what happens.

- Is there any effect on the strips of aluminium foil?
- Do they repel each other or attract each other?
- Now bring other charged bodies and make them touch the end of the paper clip.

- Do the foil strips behave in the same way in all cases?
- Can this apparatus be used to detect the presence of charge on a body or not?
- Can you explain why the strips repel each other?

The strips of aluminium foil receive the same charge from the charged refill through the paper clip. The strips carrying similar charges repel each other and hence they move apart.

This device can be used to test whether an object is carrying charge or not. This device is known as electroscope. (Earlier days gold foil used in electroscope). In the above activity you can observe that electrical charge can be transferred from a charged object to another through a metal conductor.

Touch the end of the paper clip gently with hand and you will find a change in the foil strips. They move closer and come back to their original state.

Repeat charging of foil strips and touching the paper clip. Every time you will find that the foil strips collapse as soon as you touch the paperclip with hand.

- Why does it happen?

The reason is that the foil strips lose charge to the earth through your body. We say that the foil strips are discharged.

The process of transferring of charge from a charged object to the earth is called '**earthing**'.

Earthing is provided in buildings to protect us from electrical shocks due to

10.4 The Story of Lightning



Fig-6

It is now possible to explain lightning in terms of the charges produced by rubbing. You have learnt in class 7 that during the development of a thunderstorm there will be fast movement of air currents.

The clouds moving in air acquire a charge on their surface due to the friction with particles of air. As the surface area of a cloud is very large, the amount of charge accumulated on its surface is very high.

When a charged cloud comes close to another cloud it induces an opposite charge on the latter and the accumulated charge tries to move from one cloud to another cloud. But the air present between them being a poor conductor of electricity resists the flow of charge between them. When the magnitude of the accumulated charge becomes very large, the air, which is normally a poor conductor of electricity, is no longer able to resist their flow.

Hence discharge takes place between negative and positive charges which produce streaks of bright light and sound. We see streaks as lightning. The process is called an electric discharge.

The process of electric discharge can occur between two or more clouds, or between clouds and the earth. Today we need not get frightened by lightning like the ancient people did. Now we understand the phenomenon.

Scientists are trying hard to improve our understanding. However, lightning strike could destroy life and property. It is, therefore, necessary to take measures to protect ourselves.

10.4.1 Lightning Safety

1. Which is the safe place during a thunder storm?

- A house or a building of low height
- If you are travelling in a bus or in a car you are safe inside provided that doors and windows are closed.
- If you are in a forest, taking shelter under shorter trees than a taller tree is a good idea during the thunder storm.

2. Which is not a safe place during a thunder storm?

- Travelling in an open place.
- Standing under tall trees in open fields or in a garden / park.
- Staying in multi storied building which do not have lightning conductors.
- Standing near electric poles or telephone poles.
- Speaking on landline telephones.
- Using electric appliances like T.V and computers.

Lightning Conductor

Lightning Conductor is a device used to protect buildings from the effect of lightning. A metallic rod, taller than the building, is installed in the walls of the

One end of the rod is kept out in the air as shown in fig-7. The other is buried deep in the ground. The rod provides an easy route for the transfer of electric charge to the ground.

The projected end of the metal rod is at a height more than the height of the building. Hence it receives the charge first during lightning because it is closer to the cloud than the building.

As it is a good conductor of electricity, it allows all the charge to flow through it thereby causing no damage to the building.



Fig-7

The metal columns used during construction and water pipes in the buildings also protect us to some extent. But do not touch them during a thunderstorm.

10.5 Earthquakes

Natural phenomena like lightning, floods, cyclones etc., can cause large scale destruction of human life and property.

Fortunately, these phenomena can be predicted to some extent.



The meteorological department can warn the possibility of thunderstorm developing at a particular area. If a thunderstorm occurs there is always a possibility of lightning and cyclones accompanying it. So, we get time to take measures to protect ourselves from the damage caused by these phenomena.

There is, one natural phenomenon which we are not yet able to predict is an earthquake. It can cause damage to human life and property on a huge scale.

A major earthquake occurred in India on 8th October 2005 in Uri and Tangdhar towns of North Kashmir. Before that a major earthquake occurred on 26th January 2001 in Bhuj District of Gujarat.

Activity-5

Collecting information about the damages caused by earthquakes

Ask your parents about the huge damages to life and property caused by these earthquakes. Collect a few pictures showing the damage caused by these earthquakes from newspapers and magazines of those days.

Prepare a short report on the suffering of the people during the earthquakes.

- What is an earthquake?
- What happens when it occurs?
- What can we do to minimise its effects?

Let us discuss answers these questions

10.5.1 What is an Earthquake?

An earthquake is a sudden shaking or trembling of the earth lasting for a very short period of time. It is caused by a

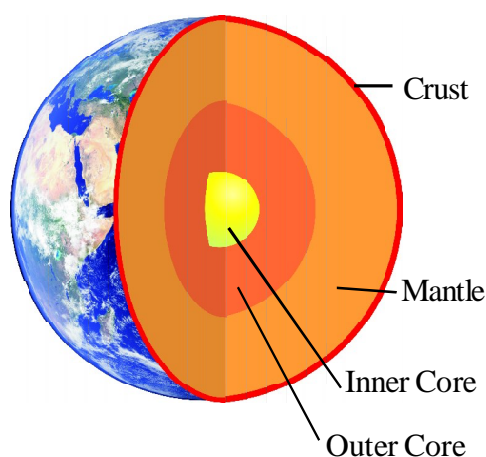

Fig-8

Some mythical/folk stories told that the earth is balanced on the horn of a bull and when the bull shifts it to the other horn, an earthquake takes place.

- How could it be true?

Earthquakes occur all the time, all over the earth. They are not even noticed. Major earthquakes are much less frequent. They can cause immense damage to buildings, bridges, dams and people.

There can be a great loss to life and property. The earthquakes can cause floods, landslides and tsunamis.

A major tsunami occurred in the Indian Ocean on 26th December 2004. All the coastal areas around the ocean suffered huge losses.

Activity-6

Locating the tsunami affected areas in the map

Take an outline map of the world. Locate the eastern coast and Andaman and Nicobar Islands in India. Mark other countries around the Indian Ocean which could have suffered damage.

Collect accounts of the devastation

caused by the tsunami in India from your parents, or other elders in the family or in the neighbourhood.

10.6 What Causes an Earthquake?

- What could cause a disturbance inside the earth?

In ancient times, people did not know the true cause of earthquakes. Their ideas were, therefore, expressed in mythical/folk stories. Similar myths were prevalent in other parts of the world.

Now we know that the tremors are caused due to the disturbance at deep down inside portion of uppermost layer of the earth crust.

The outer most layer of the earth is not in one piece. It is fragmented. Each fragment is called a plate. These plates are in continuous motion. [See fig-9(a), 9(b)]

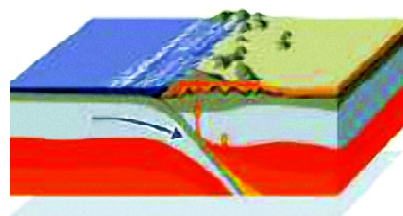

Fig-9(a)

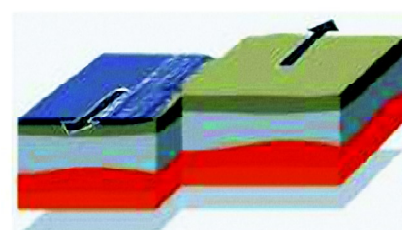

Fig-9(b)

When they brush past on one another, or a plate goes under another plate due to collision, they cause disturbance in the earth's crust.

It is this disturbance that shows up as an earthquake on the surface of the earth. However, most earthquakes are caused by the movement of earth's plates.

Since earthquakes are caused by the movement of plates, the places at boundaries of the plates are considered as weak zones where earthquakes are more likely to occur. The weak zones are also known as **seismic** or fault zones.

In India, the areas most threatened are Kashmir, Western and Central Himalayas, the whole of North-East, Rann of Kutch, Rajasthan and the Indo – Gangetic Plane. Some areas of South India also fall in the danger zone (see figure 10).

Fig-10

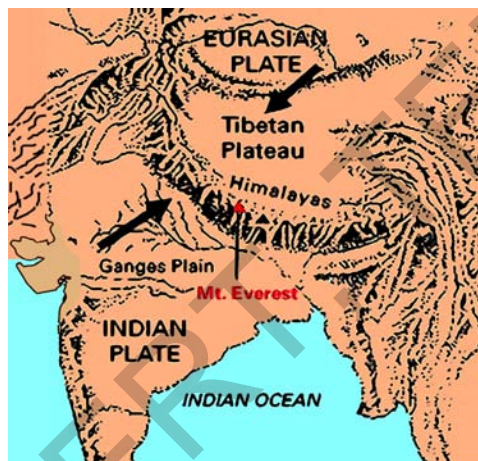

- Can we predict when and where the next earthquake takes place?
- How do we know the occurrence of an earthquake?

Seismologists use two main devices to measure an earthquake, a seismograph and a seismoscope. The seismograph is an instrument that measures seismic waves caused by an earthquake.

The seismoscope is an instrument that measures the occurrence or the time of occurrence of an earthquake. Unlike other measuring devices, the seismoscope is a simple device which can be used without any technological background.

- How do we measure the intensity of the earthquake?

The power of an earthquake is expressed in terms of a magnitude on Richter scale. The destructive earthquakes have magnitudes higher than 7.0 on the Richter scale.

Both Bhuj and Kashmir earthquakes had magnitudes greater than 7.5.

Although, we know for sure what causes an earthquake, it is not yet possible to predict when and where the next earthquake might occur. Tremors on the earth can also be caused when a volcano erupts, or a meteor hits the earth, or an underground nuclear explosion takes place.

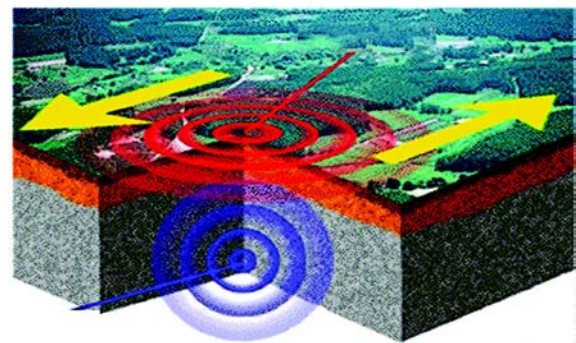

Fig-11

The tremors produce waves on the surface of the earth (see figure 11). These are called seismic waves. The waves are recorded by an instrument called the seismograph.

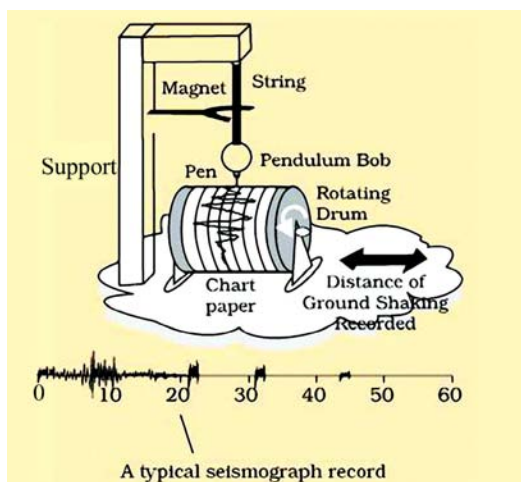

Fig-12: Seismograph

The instrument is simply a vibrating rod, or a pendulum, which starts vibrating when tremors occur. A pen (stylus) is attached to the vibrating system. The pen (stylus) records the seismic waves on a graph paper which moves under it. By studying these waves, scientists can construct a complete map of the earthquake. They can also estimate its power to cause destruction.

Like many other scales, Richter scale is not linear. This means that an earthquake of magnitude 6 does not have one and half times the destructive energy of an earthquake of magnitude 4. In fact, an increase of 2 in magnitude means 1000 times more destructive energy. For example, an earthquake of magnitude 6 has thousand times more destructive energy than an earthquake of magnitude 4.

There is another method of measuring the intensity of an earthquake using the moment magnitude scale which is based on the amount of displacement that occurred along a fault zone rather than the measurement of ground motion at a given point.

The moment magnitude measures energy released by the earthquake more accurately than the Richter scale. It is the only magnitude scale that adequately measures the size of large earthquakes.

Table - 3 : Richter scale reading - effects of earthquake

Richter magnitude	Earthquake effects
less than 3.5	Generally not felt, but recorded.
3.5-5.4	Often felt, but rarely causes damage.
5.5-6.0	Atmost slight damage to well-designed buildings. Can cause major damage to poorly constructed buildings over small regions.
6.1-6.9	Can be destructive in areas upto about 100 kilometres across where people live.
7.0-7.9	Major earthquake. Can cause serious damage over larger areas.
8 or greater	Great earthquake. Can cause serious damage in areas several hundred kilometres across.

10.6.1 Protection against earthquakes

We know from the earlier pages that earthquakes cannot be predicted. We have also seen that they can be highly destructive. It is, therefore, important that we take necessary precautions to protect ourselves all the time.



Fig-13

People living in seismic zones, where the earthquakes are more likely to occur, have to be specially prepared. First of all, the buildings in these zones should be designed so that they can withstand major tremors. Modern building technology can make it possible. It is advisable to make the structure simple so that it is 'Quake Safe'.

- Consult qualified architects and structural engineers.
- In highly seismic areas, the use of mud or timber is better than heavy construction material. Keep roofs as light as possible. In case the structure falls, the damage will not be heavy.
- It is better if the cupboards and shelves are fixed to the walls, so that they do not fall easily.

- Be careful where you hang wall clocks, photo-frames, water heaters etc. At the event of an earthquake, they do not fall on people.
- Since some buildings may catch fire due to an earthquake, it is necessary that all buildings, especially tall buildings, have fire fighting equipment in working condition.

The Central Building Research Institute, Roorkee, has developed to make quake proof houses.

Let us know what to do and how to protect at an event of an earthquake.

Inside the house:

- Take shelter under a table and stay there till shaking stops.
- Stay away from tall and heavy objects that may fall on you.

Outside the house:

- Find a clear spot, away from buildings, trees and over head power lines. Drop to the ground.

10.6.2 Earth quakes in Telangana

- Do you know the places in Telangana where earthquakes have occurred and its intensity?

According to seismic hazard map in Telangana, the city of Hyderabad lies in zone II.

Discuss about zones with your teacher.



Key words

Crust, discharge, earth's plates, earthquake, electroscope, lightning, lightning conductor, negative charge, positive charge, richter scale, seismograph, Seismoscope, thunder, thunderstorm, transfer of charge, tsunami, tremor



What we have learnt?

- Some objects can be charged by rubbing with other objects.
- There are two kinds of charges 1. positive charge, 2. negative charge
- Like charges repel and unlike charges attract each other.
- The electrical charges produced by rubbing are called static charges.
- When charges move, they constitute an electric current.
- An electroscope may be used to detect whether a body is charged or not.
- Attraction is not a sure test to know the presence of charge on a body.
- The process of transfer of charge from a charged object to the earth is called earthing.
- The process of electric discharge between clouds and the earth or between different clouds causes lightning.
- Lightning strike could destroy life and property.
- Lightning conductors can protect buildings from the effects of lightning.
- An earthquake is a sudden shaking or trembling of the earth.
- Earthquake is caused due to the disturbance deep inside the earth's crust.
- It is not possible to predict the occurrence of an earthquake.
- Earthquakes tend to occur at the boundaries of earth's plates. These boundaries are known as fault zones.
- Destructive energy of an earthquake is measured on the Richter scale. The earthquake measuring 7 or more on Richter scale can cause severe damage to life and property.
- We should take necessary precautions to protect ourselves from earthquakes.



Improve your learning



I. Reflections on concepts

1. Which instrument is used to detect a charged body? Explain with a diagram. (AS₅)
2. Which places are not safe during a thunderstorm? (AS₁)
3. List three states in India where earthquakes are more likely to occur. (AS₁)

II. Application of concepts

1. Sometimes, a crackling sound is heard while taking off sweater during winter. Why? (AS₁)
2. Give two examples of your daily life about effects which are caused by transfer of charges. (AS₁)
3. Inflate two balloons and rub both of them with a cloth first and then with different material. Will they attract each other in both cases? (AS₃)
4. Why do a charged balloon is repelled by another charged balloon whereas an uncharged balloon is attracted by a charged balloon? Explain. (AS₇)

III. Higher Order Thinking Questions

1. The weather department has predicted that a thunderstorm is likely to occur on a certain day. Suppose you have to go out on that day. Would you carry an umbrella? Explain. (AS₇)
2. Are there any alternative methods to find the intensity of earthquake? (AS₂)
3. Clouds have charges! Can we produce current through these charges? (AS₂)



Multiple Choice Questions

1. Which of the following cannot be charged easily by friction? ()
 - a) a plastic scale
 - b) a copper rod
 - c) a wollen cloth
 - d) piece of wood

2. What happens when a glass rod is rubbed with a piece of silk cloth? ()
- a) Both rod and the cloth acquire positive charge
 - b) Rod becomes positively charged while the cloth has a negative charge
 - c) Both rod and the cloth both acquire negative charge
 - d) Rod becomes negatively charged while the cloth has a positive charge
3. The magnitude of destructive earthquakes on the Richter scale is greater than: ()
- a) 3.0
 - b) 4.0
 - c) 7.0
 - d) 2.0
4. The instrument is used to estimate the intensity of earth quake is ()
- a) Seismograph
 - b) Seismoscope
 - c) Gold leaf electroscope
 - d) Lightning conductors
5. The instrument that can protect buildings from the effects of lightning ()
- a) Seismoscope
 - b) Seismograph
 - c) Electroscope
 - d) Lightning conductors



Experiments

1. Conduct an experiment to find the effects of charged bodies which have been rubbed by different materials and write report.
2. Conduct an experiment to find out the presence of charge on a body and write report.



Project Works

1. Collect the information, photos and pictures of the earthquakes occurred in Japan recently and write the report.
2. Find out if there is an organisation in your area which provides relief to those suffering from natural disaster. Enquire about the type of help they render to the victims of earthquakes. Prepare a brief report on the problems of the earthquake victims.
3. Collect accounts of the devastation caused by tsunami in India from your parents, friends and neighbourhood and write a report.



Observing the night sky is a fascinating experience for everyone. You might have watched the clear blue sky some times and also have observed sunrise and sunset several times. What have you observed in the sky? What do you know about celestial objects and their movement?

Elderly people seem to know a lot of things. Some of them can tell the time of the day simply by looking at the shadows of some objects. How do they make such guesses?

Read the following questions and check what you know about the sky and our earth.

- What are the celestial objects that we can see in the sky?
- Are the stars moving?
- Do you see the same stars at night and early in the morning?
- Do you see the same stars during summer and winter nights?
- What is the shape of the moon? Why does it change? Why doesn't the sun change its shape daily like the moon?
- Where exactly is the sun situated in the sky at noon?
- Why does the shadow of a tree change from morning to evening?

It is definitely interesting to know answers to the above questions, but it will be more interesting to understand how our ancestors came to an understanding about all these in the olden days and what they observed and how they observed the sky and celestial bodies without using instruments like telescopes.

One thing we have to remember that people made these observations from the earth and not from any other point in the sky. We shall now perform some activities which will help us understand the above questions with some insights.

11.1 Observing the changes in the length of shadow

Activity-1

This experiment should be performed on a day when the sky is clear, preferably between nine in the morning and four in the evening.

Pick a spot in the open ground where you can be sure to have sunlight throughout the day. Also there should not be any trees or buildings nearby which can cast a shadow on this spot during the period of the experiment. The spot should be as flat as possible.

Take a stick which is a little over a meter long and fix it vertically in the ground. Ensure that exactly one meter of the stick remains above the surface of ground. You could even build a fence around your stick as shown in figure-1 to keep people away from it.



Fig-1: Changes in lengths of shadow

Make your first observation at nine in the morning. Make a mark with a nail or peg at the point where the tip of the shadow falls on ground. Measure the length of the shadow. Then, make similar observations for every half an hour throughout the day till four in the evening. Use a clock to fix the time for making your observations. Enter the measurements of the length of the shadow and the time of measurement in a table making two columns, one for time and another for length of shadow.

(Since you will be making observations over the next two weeks at least, you should ensure that the pegs and stick are not disturbed.)

- Look at your table and figure out the time of the day of shortest shadow.
- When did you observe the longest shadow in your activity?
- How does the length of the shadow change with time?

Draw the diagrams of the stick and its shadow for 5 different times, that is, at 9am, 11 am, 12noon, 2pm, and 4pm.

- If you continue your activity from sunrise to sunset, at what times do you think the shadow would be the longest?
- Where is the sun situated in the sky at noon? Where does the shadow of stick fall at that time? Think about how your own shadow will be at that time.
- Do you think that your shadow will be the same on all the days at noon?
- In which direction does the shortest shadow of the stick fall in your activity?

The shortest shadow cast by a vertical object on the ground (shadow formed on midday) always falls in the north–south direction. You can use this fact to locate directions. The time when the shortest shadow occurs is called the local noon time at that place.



Think and Discuss

Look at the nails or pegs you have fixed on the ground to keep track of the shadow of the stick throughout the day. From their positions, can you tell how the position of the sun changes in the sky from sunrise to sunset?

Continue your observations

Observe on the next day whether the shadow of the stick falls at the same spots

Can you use your stick as a clock (sun dial) to tell the time? If your answer is 'yes', explain how this is possible.

Two weeks later, once again check to see whether the stick's shadow falls at the same spots at the same times during the day.

- If the shadow does not fall on the same spot, what could be the possible reason?

You observed in activity 1 that the position of the sun in the sky changes during the day. If you continue your experiment for a full year, you will find that the position of the sun changes from day to day as well.

That is, the position of the sun at 10am today will be different from its position two weeks later at the same time. If you choose a particular time every week and mark the position of the sun with a peg at that time, you can build a calendar for the full year. You could use this calendar for the following year to figure out dates.

In the olden days, people used to calculate the time by observing the shadows of different objects.

- During a period of two weeks you had made an observation that the length of the shadow at a particular time is changing day by day. Did it become longer or shorter?
- By observing the direction of shadows, can you guess the arrival of summer or winter?

Does the sun rise at the same spot throughout the year? Let us do an activity to understand this.

11.1.1 Understanding the North – South movement of the sun.

Activity-2

Fix a spot near your home from where you can observe the sunrise. You may have to go to the terrace of a RCC building or go to an open field for the purpose. Choose a tree, electric pole or some other stationary object as a reference point. Over the next 10 to 15 days, note the spot at which the sun rises daily, keeping in mind your reference point. Make a daily sketch of the rising sun as shown in figure-2. (Daily sit and observe from same place)



Fig-2 : Observing the position of sun

- Does the spot of sunrise change? If it does, in which direction does it seem to move?

When the sun looks like travelling towards south of the sky, it is called the **dakshinayanam**. When it looks like travelling towards north of the sky it is called the **uttarayanam**. (Ask your parents about Uttarayanam and Dakshinayanam)

- You have observed the sun for 2 weeks! Was the sun appear travelling towards south or north during the time you made your observations?
- Do you think that is the reason for the change in the length of the shadow of the stick day by day in activity 1?
- If we do not have any calendar and knowledge of months and seasons, can you use movement of the sun to predict the arrival of winter or summer?



Think and Discuss

Why does the sun appears to travel towards north or south? Try to find the answer by reading your social studies chapter “**Earth movements and seasons**” along with this lesson.

Collect the information : Are the timings of rising and setting of the sun same every day? Collect the information from news papers for at least a period of a fortnight. Think why the lengths of day and night are different every day. Try to get answers through internet or from other books or from teachers.

Activity 1 can be used to make a **sundial** (a clock based on shadows of an object due to sunlight). But the length of the shadow of our stick is changing day to day because of the north – south movement of the sun which is a problem in making a sundial.

People in olden days overcame this problem and made sundials also.



Do you know?

The Jantar Mantar monument in Jaipur, Rajasthan state is built by the Rajput king sawai Jai Singh-II. It features the world’s largest stone sundial and is a UNESCO’s world heritage site.

How can we make our own sundial?

11.1.2 Make your own sun-dial

Activity -3

First of all, cut a right-angled triangle ABC from a sheet of cardboard. Angle C of the triangle should equal to the latitude of your city or town and angle A should be 90 degrees, as shown in figure 3. (Latitudes of different districts are given in table-1.)

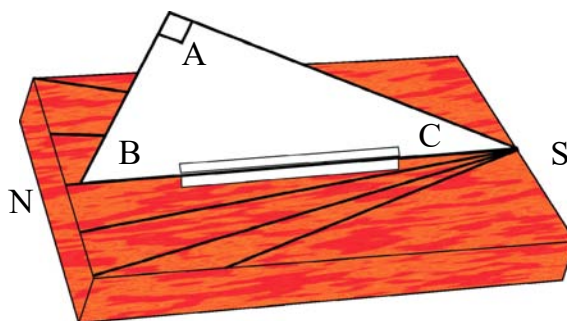

Fig-3 Sun dial

Fix your cardboard ABC triangle vertically in the middle of a rectangular wooden board. Glue strips of paper along both edges of BC and the wooden board to make the triangle stand erect as shown in the figure.

Place your board with the triangle on level ground in an open space which gets sunlight throughout the day.

Base BC of the triangle should be placed in the north-south direction, with B pointing to the north.

At 9 in the morning, draw a line along the shadow of side AC on the wooden board. Write the time alongside the line. Draw lines of the shadow of side AC at one-hour intervals (use a clock to check the time) through the day till sunset and mark the time for each line. Your sun-dial is ready.

You can tell the time by looking at the shadow on the sun-dial. But remember that base BC of the triangle in the sun-dial must always be in the north-south direction if you wish to read the time correctly.

(You can find out the north-south direction at a place by using a stick like in Activity 1, but don't use magnetic compass.)

A list of latitudes of districts of Telangana is given below in table-1.

Table -1

Sl.No.	Districts	Latitude in Degree North (rounded to whole number)
1.	Mahabubnagar	16
2.	Ranga Reddy, Hyderabad, Khammam, Nalgonda	17
3.	Medak, Nizamabad, Karimnagar, Warangal	18
4.	Adilabad	19

Now we will try to know a few things about the moon.

- Have you ever observed the movement of moon in the sky?
- Does the moon appear at same point at a particular time every day?
- Is the shape of the moon same on every day?

To understand these issues, let us do some activities. (You can do these activities on your own at home.)

Activity-4

11.1.3 Observing phases of the moon



1. Note the date of the day after new moon day (Amavasya), when the moon first appears in the sky.

Also note the time at night when the moon sets (goes down in the western sky). In the same way every day locate the moon in the sky at the time of sunset or immediately after sunset.

Record the date and time of the moon set and draw a picture of the moon as you see it on that day in your note book as shown



Fig-4: Drawing the phases of the Moon

Continue making observations for as many nights as possible.

2. Observe the moon a few days before full moon day (Pournami) to a few days after it. Locate the position of moon in the sky at the time of sunset before Pournami and note the time and position of moon in the sky at that time.

After Pournami, note the time at which the moon rises (comes in the eastern sky) and also note the date. Draw pictures of the shape of the moon on each of these days.

What do you understand from these observations?

- Can you calculate the number of hours between one moon rise and the next moon rise or the number of hours between one moon setting and the next moon setting, with help of these observations?
- How many hours lapse between one sunrise to the next, or one sunset to the next?
- Is the time period same for sun and moon to appear at selected position after completing a cycle in the sky every day?
- Does the moon appear at the same point every day during the time of the sunset?
- What is the shape of the moon? Is it same every day?

You might have observed that the shape of the moon changes night after night. These changes in its appearance are called the phases of the moon. Can you guess why the shape of the moon changes?

You may have noticed that the time period taken by sun to complete a cycle in the sky and come to selected position is almost same every day and it is about 24 hours i.e. 1 day. Whereas moon takes about 50 minutes more than a day to complete the cycle and which results in the phases of the moon.

Let us perform two activities to understand why the phases of moon occur.

Activity-5

11.1.4 A Moon-shaped lemon

Choose a day one week after the new moon day when the moon is visible in the sky before the sunset.

Take a yellow lemon or a whitewashed clay ball and pivot it on a long needle or on a spoke of bicycle and hold it up as shown in figure-5 and stand in evening sun.

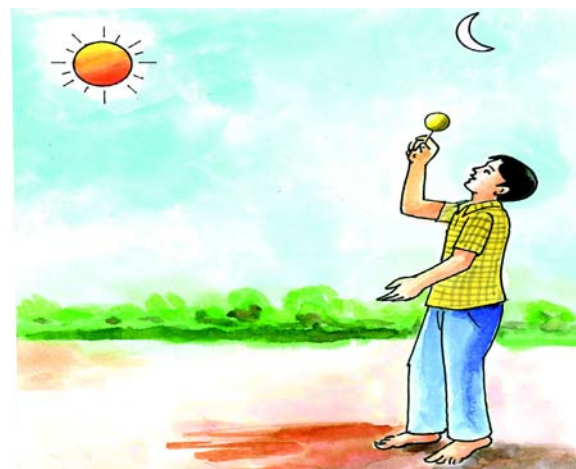

Fig-5 : Observing the shape formed by sun light on a lemon

Observe the shape formed by the sunlight on the surface of the lemon by keeping lemon towards the moon.

- Is there some similarity between the shape formed and the shape of the moon?

Activity-6

Why does the shape of the moon change?

(Do this activity around 4p.m.)

Wrap a ball tightly with a white handkerchief or with a piece of white cloth. Assume this is the moon. Hold this ball in front of your eyes in bright sunshine as shown in figure 6 and turn around yourself slowly. Observe how the shape of the illuminated part of the ball changes.



Fig-6

- Does sunlight fall on half the ball at all times while you turn around?
- Is the shape of the illuminated part on the ball viewed by you same in all positions during your rotation?
- Why does this happen?

To understand the reason better, look at figure-7 carefully.

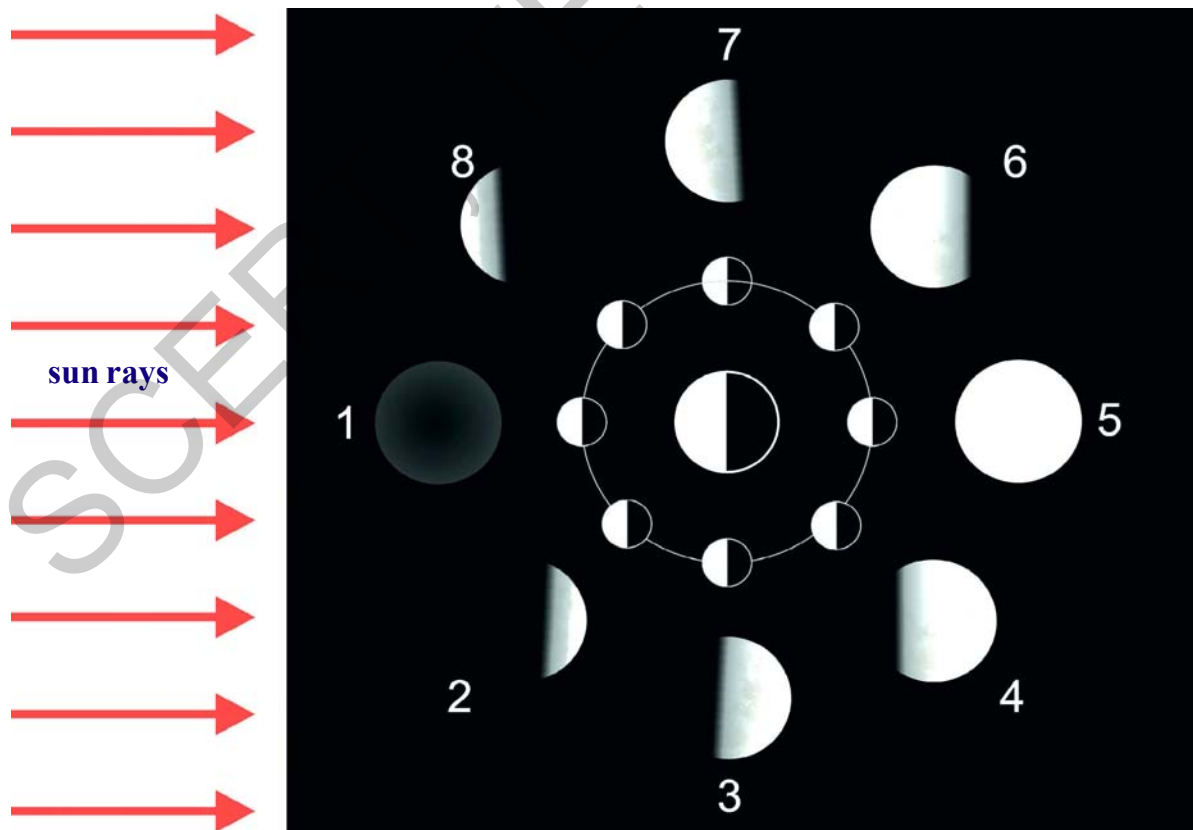

Fig-7 : Phases of moon

The large circle in the middle of figure 7 is the earth and the smaller circles around it represent the moon in different positions. You can also see the phases of the moon on different days in the figure. The sunrays falling on the moon illuminate half its surface in all the positions. However, we cannot see the entire illuminated surface from the earth in all the positions. In some cases we see the entire illuminated surface while in others we see only part of it. In one particular position, we cannot see the illuminated surface at all.

The shape of the moon we see is the shape of the illuminated portion visible to us. In figure 7, the day of the new moon is called day 0 or day 28 (position 1). In this position, the illuminated surface is not visible from earth, so the moon cannot be seen from earth.

Four days later, when the moon is in position 2, a small part of its illuminated surface is visible from earth. On day-7, the moon is in position 3, so more of its illuminated part is visible from earth.

After fourteen days (at position 5) the entire illuminated surface of the moon is visible from earth. This is the day of the full moon.

Subsequently, the moon appears smaller with each day as it passes through positions 6 (day-18), 7 (day-21) and 8 (day-25). After 28 days, the moon is once again in position 1.

Try to duplicate position 1 with the ball. For this, you will have to hold the ball towards the sun (between your eyesight and the sun).

- In this position, which half of the ball is illuminated?

Although half the surface of the moon is illuminated everyday, we cannot see the moon on new moon day since the illuminated surface is on the side opposite to the point of observation on the earth. On a full moon day, the situation is reversed. The illuminated half of the moon faces the point of observation, so we see a full moon.

From the above explanation, you may have understood that the sun and moon must be on the same side of the earth on a new moon day and they are on opposite sides of the earth on a full moon day.

During the phases in between, we see different shapes of the moon.

Hold the ball in different positions and draw pictures of the shapes of the visible illuminated portion in each case.

The different shapes of the moon in its different phases, as seen from the earth, are shown in figure 7. Compare the drawings you have made with those in figure 7.

- Can you now state as to in which direction the moon will rise on a full moon day?

While we observe moon in clear sky on a full moon day, we think about the spots those are visible on the moon. In olden days also people were curious about those spots on the moon. They did not know the nature of the surface of moon as we know it today. This led to creation of a lot of stories and myths about the spots on the moon.

- Do you know any such stories?

Today we have many satellites that observe the surface of the moon. Human beings landed on the moon way back in 1969. We have better information about moon's surface than our ancestors.

11.2 The surface of the moon

When astronauts landed on the moon, they found that the moon's surface is dusty and barren. There are many craters of different sizes. It also has a large number of steep and high mountains. Some of these are as high as the highest mountains on the earth. But the moon has no atmosphere like that on the earth.

- Will we be able to hear any sound if we were on the moon? Why?
- Can any life exist on the moon? Why?



Think and Discuss

Scientists are planning to build settlements on moon and are trying to make arrangements to live there. You know that there is no air on moon. How will it be possible to live on the moon then?



Do you know?

Our country launched Chandrayan-1 (Satellite to Moon) on 22nd October 2008 to know about the moon.

The objectives of Chandrayan-1 are:

1. To check the possibility of finding water on the moon
2. Finding out the elements of matter on moon
3. To search for Helium-3
4. To make 3-dimensional atlas of the moon
5. To study about the evolution of the solar system

Now India is one of the six countries which have sent satellites to the moon. Search the findings of Chandrayan-1 on internet or in news papers.



We feel pleasant during the night of full moon. But sometimes on full moon day the moon loses its brightness for some time, it appears covered – partially or fully. This is called **Lunar eclipse**. Why does the moon get covered? Like the moon, the sun also gets covered partially or fully on some of the new moon days. This is called **Solar eclipse**. Let us try to understand these phenomena.

11.3 Solar Eclipse

A solar eclipse occurs when the shadow of the moon falls on the earth. It occurs only on new moon day.

Types of solar eclipse

1. **Total Solar eclipse:** It occurs when the moon completely covers the Sun, as seen from earth.
2. **Partial Solar eclipse:** It can be observed when only the partially shaded outer region of the shadow cast by moon (Lunar penumbra) touches the earth.
3. **Annular eclipse:** It occurs when the moon appears smaller than the sun as it passes centrally across the solar disk and a bright ring or annulus of sunlight remains visible during eclipse.
4. **Hybrid eclipses:** These are a rare form of Solar eclipse, which changes from an annular to a total solar eclipse along its path.

11.4 Lunar eclipse

A lunar eclipse occurs when the shadow of the earth falls on the moon. It occurs only on full moon day.

Types of lunar eclipse

- 1. Total Lunar eclipse:** It occurs when the earth's shadow(Umbra) obscures all of the moon's visible surface.
 - 2. Partial Lunar eclipse:** It can be observed only when part of the moon's visible surface is obscured by the earth's shadow.
 - 3. Penumbral Lunar eclipse:** It happens when the moon travels through the partially shaded outer region of the shadow cast by the earth(earth's penumbra).
- Why does a lunar eclipse occur only on a full moon day?

- According to figure-7, in which position can the shadow of the earth fall on the moon?
- Can this position occur only on one particular day?
- Can you now explain why a solar eclipse occurs only on a new moon day?

However, why is it that a solar eclipse does not occur on every new moon day and a lunar eclipse does not occur on every full moon day? Let us try and understand the reason.

A total solar eclipse occurred on the afternoon of **February 16, 1980** (it was seen in Mahaboobnagar, Nalgonda and Khammam districts in Telangana.) Because the total sun was covered during the eclipse, it looked like night during the day time.

Figure 8 contains a sketch of the time exposure photograph of this eclipse. That means the exposures of the different stages of the eclipse were made at 10-minute intervals on the same frame.

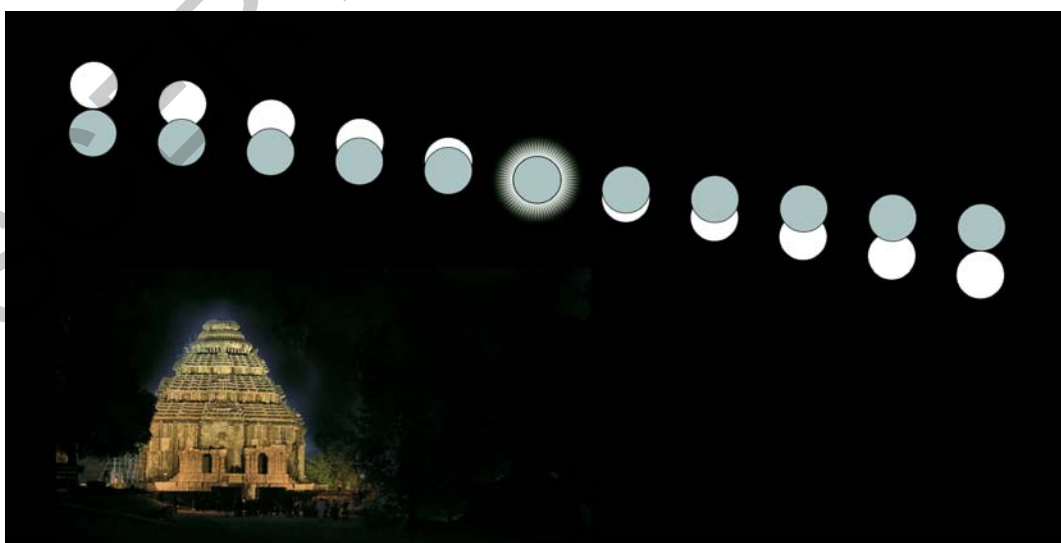

Fig-8

The sketch from left to right shows the moon slowly covering the sun and then moving away. The uncovered portion of the sun appears white and the black circles represent the moon in the sketch. You can easily guess the position of the moon at each stage of the eclipse. Can you draw lines tracing the paths of the sun and moon in the sketch?

The white portions of the discs in figure-8 represents the sun and the black portions represents the moon. Each of these discs depict the position of the sun and moon at various stages of the eclipse.

Make discs, one white and the other black, as the size of sun and moon as in figure-8.

We shall now find the centers of the sun and moon at each stage. To do this, take the white disc you have made and place it exactly on the white portion of any of the stages in the diagram.

Pierce a hole through the center of your disc with a pin to mark the spot at the center of the sun's position at that stage in the diagram. Remove the white disc and mark the spot with a pencil.

In this way, mark the sun's center at every stage of the eclipse in your diagram. Join these spots with a line. This line depicts the path of the sun.

To find the moon's path, repeat the exercise, but this time use the black disc and mark the centers of the black portions at each stage of the eclipse. Join these spots with a line and you will get the path of the moon during the eclipse.

Do the sun and moon follow parallel paths or do their paths cross each other during the course of the eclipse?

There is another aspect to note in figure-8. The sun and moon reached the point of intersection of their paths at exactly the same time during the eclipse on February 16, 1980.

- If this had not happened, would a total solar eclipse still have occurred?
- Can you now tell why a solar eclipse does not occur on every new moon day?

What would be the difference in the position of the sun and moon on new moon days when no eclipse takes place and when there is an eclipse? Use the sketch to try and figure out your answer.

Some other fascinating celestial objects in the sky are stars. They usually appear in groups and members of these groups when viewed together form different shapes. People used to assign some shapes of animals and human being to those small groups. Those groups are called constellations. A group of stars which contains millions of stars are called galaxy. Millions of galaxies together make our universe.

11.5 Let us know something about stars

When you look at the night sky, do the stars appear to be moving? If you wish to study the movement of stars across the sky and to trace their paths you must observe the pole star, the seven stars of the Saptarishi (Great Bear) constellation and the six stars of the Sharmistha (Cassiopeia) constellation.

You can easily recognize the great bear with its rectangular head in the northern sky shown in figure 9a.

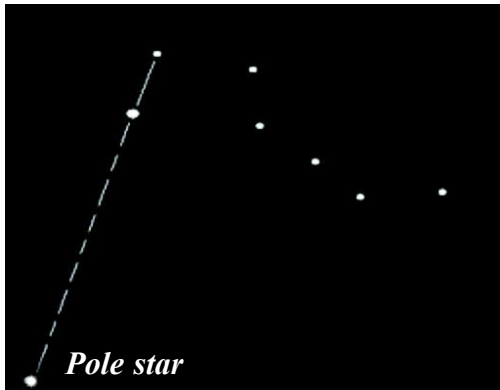

Fig-9(a): Great bear constellation (saptarishi) - position of pole star

In winter, this constellation rise a few hours before sunrise (we can see this from anywhere in Telangana). In this season, you can also see Cassiopeia in the same part of the sky, its six stars forming the letter 'M'. (see fig. 9(b))

You can locate the pole star (Polaris) with the help of these two constellations. If you are able to spot only the great bear, look at the two stars that form the outer side of its rectangular head. Extend an imaginary line from these two stars (as shown in figure 9a). The pole star will be located on that extended line with a distance of about 5 times the distance between these two stars.

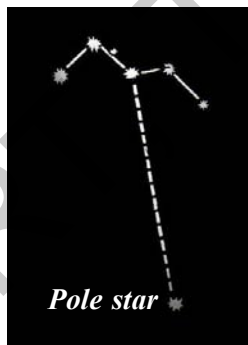

Fig-9(b): Cassiopeia constellation (Sharmistha) - position of pole star

Extend an imaginary line from these two stars (as shown in figure 9a). The pole star will be located on that extended line with a distance of about 5 times the distance between these two stars.

If only Cassiopeia is visible, the pole star will be located on a line extended from the middle star of the 'M' (see figure 9b).

Once you have located the Great Bear, Cassiopeia and pole star in the night sky, do the following activity.

Activity -7

Observing the movement of constellations (stars)

Take a 20cm x 20cm square sheet of paper and make a 1cm diameter hole in its center. Mark a cross (X) on one side of the sheet of paper as shown in figure 10.

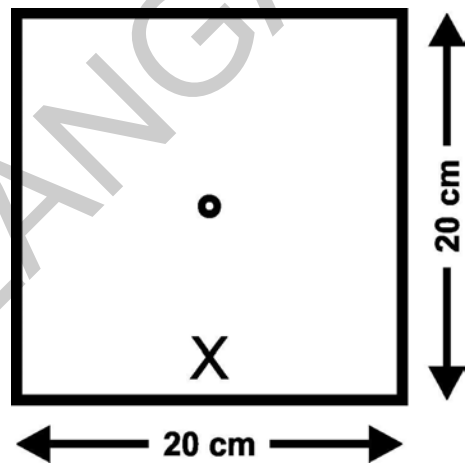

Fig-10

Hold the sheet in front of your eyes with the 'x' mark at the bottom and look for the pole star through the hole. Once you have located the pole star, check in which direction the Great Bear or Cassiopeia lie.

Write 'G' for Great Bear and 'C' for Cassiopeia on the paper in the directions in which you see each of the constellations. Mark the timing at which you made your observation in both cases.

Choose a nearby tree or house as a reference point. Draw a picture of your reference point on the paper sheet taken, clearly indicating its location.

Repeat your observations at one-hour intervals. Ensure that you are standing on the same spot each time you look at the stars.

Write G, C in the direction of the position of the great bear and Cassiopeia during each observation and note the time of the observation next to the letters G and C. Using the tree or house you have chosen as your reference point, check whether the position of the pole star has changed or not. If it has changed, note the changed position.

Repeat this activity as many times as possible, the minimum being four times. But ensure that the 'X' mark on your sheet of paper remains at the bottom during all your observations.

You could also use other known stars or constellations close to the pole star to perform this activity.

Study the picture you have drawn and answer the following questions.

- Do the positions of the stars change with time?
- Does the position of the pole star also change with time?
- Does the shape of the great bear and Cassiopeia change with time or does the position of the entire constellations in the sky change?
- What kind of path do these constellations trace in the sky?

From your observations, you would have realized that the stars do not remain in the same spot in the sky but revolve around the pole star. The pole star, however, remains fixed at one place. It takes the stars 24 hours to complete a revolution around the pole star. We can observe only half this revolution during the course of a night.

If all stars move, why doesn't the pole star move? Let us try to understand it by doing the following activity.

Activity -8

The pole star appears fixed at one point.

Why?

Take an umbrella and open it. Make about 10 – 15 stars out of white paper having 5 cm length, 2.5 cm breadth. Paste one star at the position of the central rod of the umbrella and others at different places on the cloth near the end of each spoke as shown in figure-11.



Fig-11

Now rotate the umbrella by holding its central rod in your hand. Observe the stars on the umbrella. Is there any star which does not appear moving? Where is this star located? Is it located where the rod of the umbrella holds the cloth of the umbrella?

On similar lines, if there were a star located where the axis of rotation of the earth meets the sky, could this star also be stationary?

As shown in figure-12 the pole star is situated in the direction of the earth's axis and that is why it does not appear to move even though all stars appear that they are moving because of the rotation of the earth.

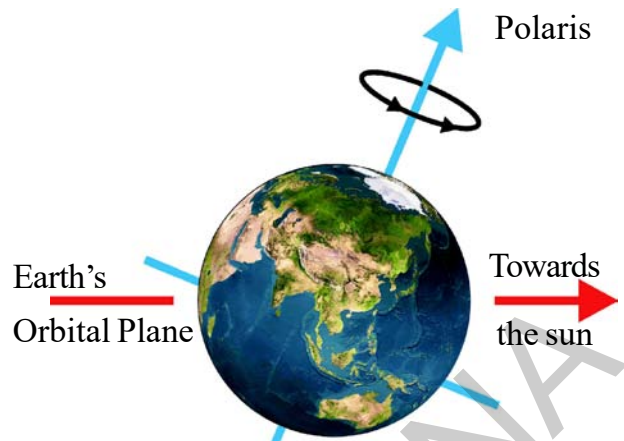

Fig-12: Direction of Pole Star

Some of the constellations visible from Telangana



Fig-13: Saptha rashi

Sharmista

Orion

Leo (Simha Rashi)

Some of the Galaxies in our Universe

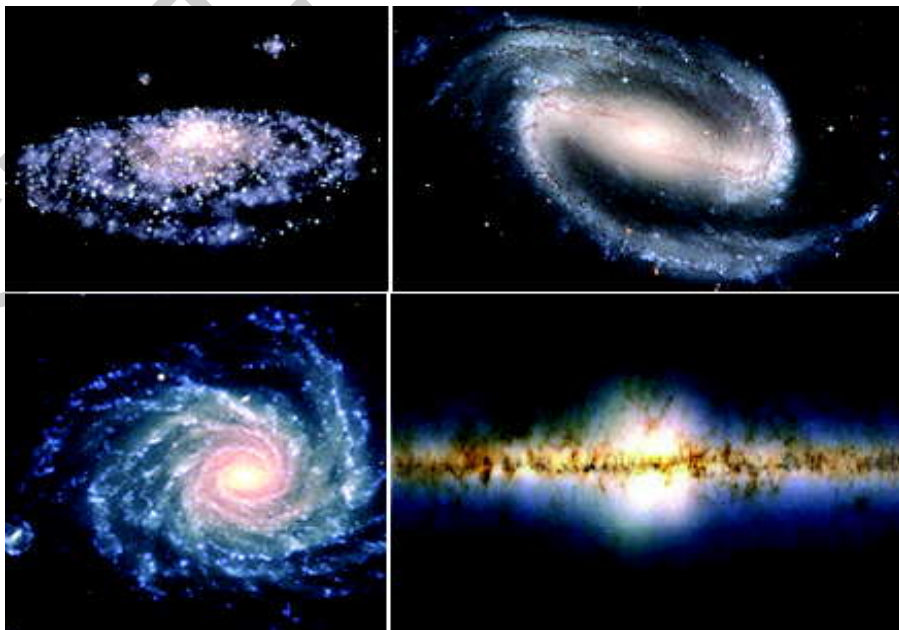

Fig-14

Among millions of galaxies, our sun is a star in Milky Way galaxy. Our earth is revolving around the sun. And moon is revolving around the earth. Do you know that not only the earth but also some other celestial bodies are revolving around the sun? Let us know something about those celestial bodies.

11.5.1 The solar system

The sun and the celestial bodies which revolve around it form the solar system. It consists of large number of bodies



such as planets, comets, asteroids and meteors. The gravitational attraction between the sun and these objects keeps them revolving around it.

The earth revolves around the sun. It is a member of the solar system. It is a planet. There are seven other planets that revolve around the sun. The eight planets in their order of distance from the sun are: Mercury, Venus, Earth, Mars, Jupiter, Saturn, Uranus and Neptune.

Figure-15 shows a schematic view of the solar system. Not to the Scale.

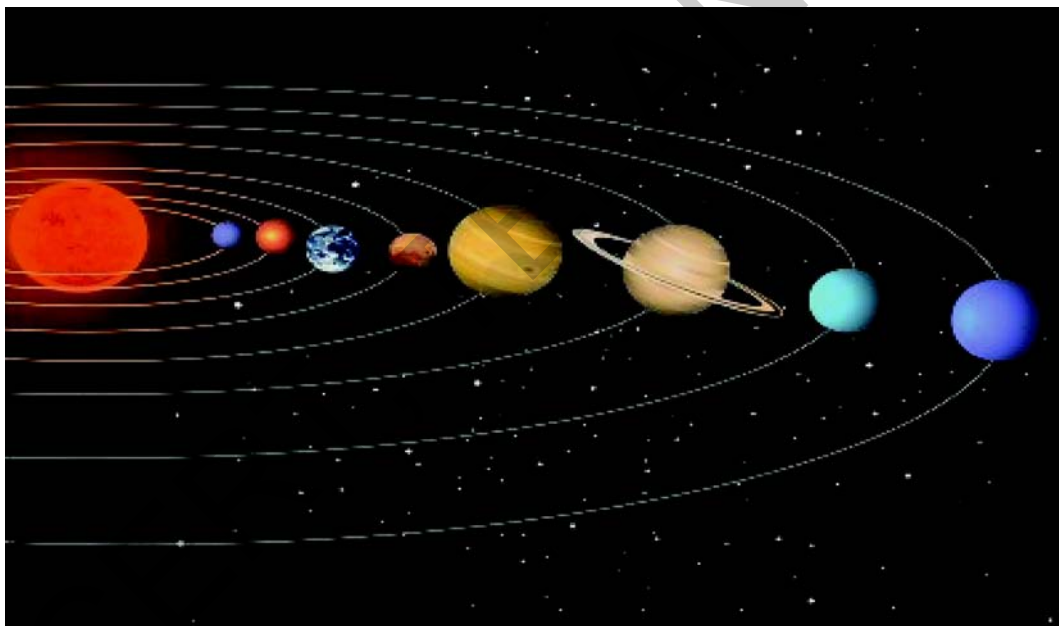

Fig-15

Let us learn about some members of the solar system.

The Sun

The Sun is the nearest star to us. It is continuously emitting huge amounts of heat and light.



The sun is the source of almost all energy on the earth. In fact, the sun is the main source of heat and light for all planets of our solar system.

The planets

The planets look like stars, but they do not have light of their own. They merely reflect the sunlight that falls on them.

A planet has a definite path in which it revolves around the sun. This path is called an **orbit**. The time taken by a planet to complete one revolution is called its **period of revolution**. The period of revolution increases as the distance of the planet from the sun increases.

Besides revolving around the sun, a planet also rotates on its own axis like a top. The time taken by a planet to complete one rotation is called its **period of rotation**.

Some planets are known to have moons/satellites revolving round them. Any celestial body revolving around another celestial body is called its **satellite**.

The earth revolves around the sun. Does it make earth a satellite of the sun?

The earth and other seven celestial bodies can be said to be as satellite of the sun, though generally we call them as planets of the sun. We use the term satellite for the bodies revolving around planets. Moon is a satellite of the earth. There are many man-made satellites revolving round the earth. These are called **artificial satellites**

Mercury (Budhudu)

The planet mercury is nearest to the sun. It is the **smallest planet** of our solar system.



Because mercury is very close to the sun, it is very difficult to observe it, as most of the time it is hidden in the glare of the sun. However, it can be observed just before sunrise or just after sunset, near the horizon.

So it is visible only at places where trees or buildings do not obstruct the view of the horizon. Mercury has no satellite of its own.

Venus (Sukrudu)

Venus is earth's nearest planetary neighbour. It is the **brightest planet** in the night sky.



Sometimes, Venus appears in the eastern sky before sunrise. Sometimes, it appears in the western sky just after sunset. Therefore, it is often called **a morning or an evening star**, although it is not a star. Try to locate Venus in the night sky during early winter.

Venus has no satellite of its own. Rotation of Venus on its axis is somewhat unusual. It rotates from east to west while the earth rotates from west to east.

- Does the sun rise in the east on Venus?

If you get a chance, try to observe Venus through a telescope. You will observe that Venus shows phases just like the moon.

The Earth (Bhoomi)

The earth is the only planet in the solar system on which life is known to exist.

Some special environmental conditions are responsible for the existence and continuation of life on the earth. These include just the right distance from the sun so that it has the right temperature range, the presence of water and suitable atmosphere and a blanket of ozone. We must take special care to protect our environment so that life on earth is not disturbed.

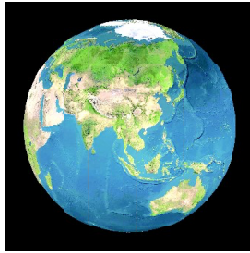

From space, the earth appears blue-green due to the reflection of light from water and landmass on its surface. The earth has only one moon revolving around it.

Mars (Kujudu / Angarakudu)

The first planet outside the orbit of the earth is mars. It appears slightly reddish and therefore, it is also called the **red planet**. Mars has two small natural satellites (moons).

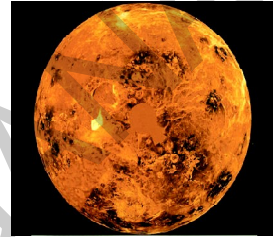

Mars science laboratory: National Aeronautic and Space Administration (NASA) in America started a mission called 'Mars Science Laboratory' on 26th November 2011, to know more about Mars. A rover named 'Curiosity' landed on Mars on 6th August 2012. It is analyzing the elements in the rocks of the surface of the Mars. It found few indications of water on Mars. It is searching whether the favorable conditions for life exist on Mars.



Jupiter (Brihaspati)

Jupiter is the **largest planet** of the solar system. It is so large that about 1300 earths can be placed inside this giant planet. However, the mass of Jupiter is about 318 times that of our earth. It rotates very rapidly on its axis. Jupiter has a large number of satellites.



It also has faint rings around, appears quite bright in the sky. If you observe it with the help of a telescope, you can also see four of its large moons.

Saturn (Shani)

Beyond Jupiter is Saturn. It appears **yellowish** in colour.

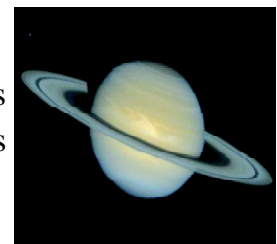

These rings are not visible to the naked eye. You can observe them with a small telescope. What makes it unique in the solar system is that it has rings. Saturn also has a large number of satellites.

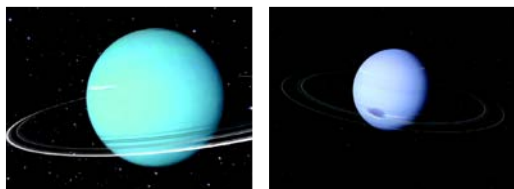

Uranus

Neptune

Uranus and Neptune

These are the outermost planets of the solar system. They can be seen only with the help of large telescopes. Like Venus, Uranus also rotates from east to west. The most remarkable feature of Uranus is that it has highly tilted rotational axis (figure 16). As a result, in its orbital motion it appears to roll on its side.

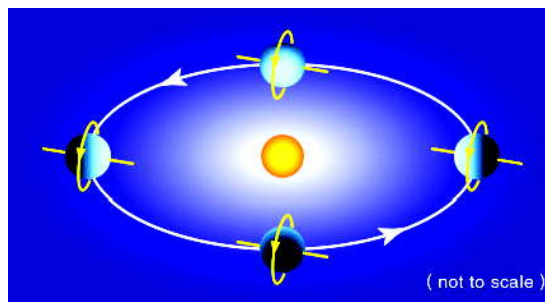

Fig. 16

The first four planets, mercury, venus, earth and mars are much nearer the sun than the other four planets. They are called the **inner planets**. The inner planets have very few moons.

The planets outside the orbit of Mars, namely Jupiter, Saturn, Uranus and Neptune are much farther away from the sun than the inner planets. They are called **outer planets**. They have a ring system around them. The outer planets have a large number of moons.

Table-2 : Comparison between planets

Name of the Planet	Comparative Diameter with Diameter of Earth (Approximately)	Distance from the Sun in Crore km. (Approximately)	Period of revolution (Approximately)	No. of satellites (detected so far)
Mercury	0.38	5.79	88 days	0
Venus	0.95	10.8	225 days	0
Earth	1	15	365 days	1
Mars	0.53	22.8	687 days	2
Jupiter	11.20	77.8	12 years	71
Saturn	9.45	142.7	29.5 years	62
Uranus	4.00	286.9	84 years	27
Neptune	3.88	449.7	165 years	14

We took Earth's diameter (12756 Km) as 1 unit. With this information find the diameters of other planets using the comparison given in table-2.



Think and Discuss

The diameter of the sun is 13,92,000 Km.

The diameter of the earth is 12,756 Km.

The diameter of the moon is 3,474 Km.

The distance from the sun to earth is 15,00,00,000 Km.

The distance from the earth to moon is 3,84,399 Km.

Take the scale as 1 lakh km = 1 cm, and imagine how the arrangement of sun, earth and moon is in our universe. Can you make this arrangement on your school ground?



Do you know?

Till 25th August 2006 we used to say there are nine planets in our solar system. The ninth planet at that time was 'Pluto'. In the 26th general assembly of International Astronomical Union it was decided that 'Pluto' is no more a planet. The decision was taken since it was observed that Pluto does not follow the rule of "cleared the neighborhood." That means, sometimes it is entering into the orbit of Neptune.

11.6 Some other members of the solar system

There are some other bodies which revolve around the sun. They are also members of the solar system. Let us know about some of them.

Asteroids

There is a large gap in between the orbits of mars and Jupiter as in figure-17.

This gap is occupied by a large number of small objects that revolve around the sun. These are called asteroids. Asteroids can only be seen through large telescopes.

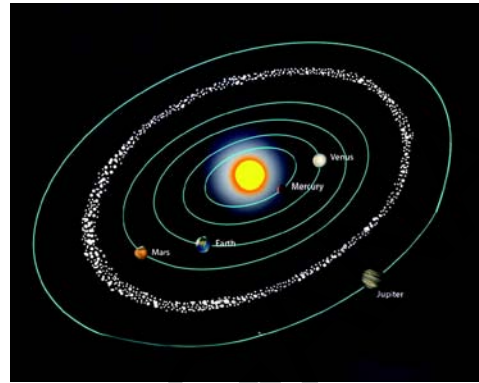

Fig. 17

Comets

Comets are also members of our solar system. They revolve around the sun in highly elliptical orbits. However, their period of revolution round the sun is usually very long. A comet appears generally as a bright head with a long tail. The length of the tail grows in size as it approaches the sun. The tail of a comet is always directed away from the sun (fig.-18).

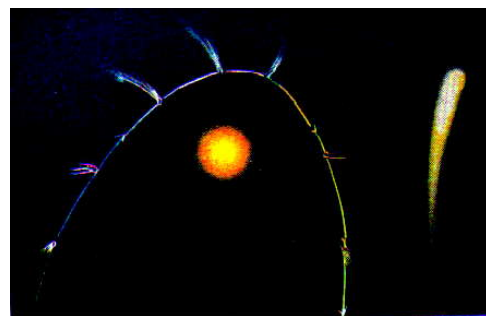

Fig. 18

Many comets are known to appear periodically. One such comet is Halley's comet, which appears after every 76 years. It was last seen in 1986. Can you tell when Halley's comet will be visible again?

Meteors and Meteorites

At night, when the sky is clear and the moon is not visible, you may sometimes see bright streaks of light in the sky (fig.19).



Fig. 19

These are commonly known as shooting stars, although they are not stars. They are called meteors. A meteor is usually a small object that occasionally enters the earth's atmosphere. It has a very high speed. The friction due to the atmosphere heats it up. It glows and evaporates quickly. That is why the bright streak lasts for a very short time. Some meteors are large and so they can reach the earth before they evaporate completely. The body that reaches the earth is called a meteorite (figure-20).

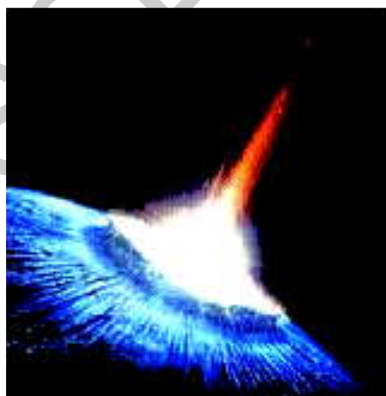

Fig. 20

Meteorites help scientists in investigating the nature of the material from which solar system was formed.

Artificial satellites

You must have heard that there are a number of artificial satellites which are orbiting the earth. Artificial satellites are man-made. They are launched from the earth. They revolve around the earth much closer than earth's natural satellite, the moon.

India has built and launched several artificial satellites. Aryabhata was the first Indian artificial satellite (figure-21).

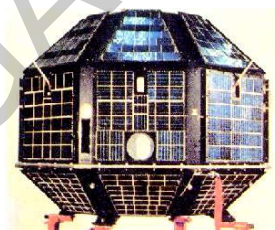

Fig. 21

Some other Indian satellites are INSAT, IRS, Kalpana-I, EDUSAT, etc.

Artificial satellites have many practical applications. They are used for forecasting weather, transmitting television and radio signals. They are also used for telecommunication, remote sensing (collecting information from a distance) in aviation and military use.

This information about solar system is known to us for the past 2 to 3 hundred years, after the telescopes were made. But how did the people of olden days know so much about the celestial bodies and also about earth?

Let us know about some of the interesting constructions of their knowledge.

11.7 How did people come to an understanding that earth is spherical?

In olden days people felt that earth is flat because it looks flat. However they had a doubt, if it is flat how does the water in oceans remain there, why does it not spill out of the earth? To get clarity they assumed a fencing around the flat earth. After that

1. They assumed the shape of earth as round by observing the shadow of earth in lunar eclipse. In every eclipse they found the shape of earth is in round even though there is a chance of getting linear, elliptical shadows by a circular object.
2. Some sailors, who started their journey in ocean, reached the same place after travelling large distance in one direction only.
3. Observing ships approaching the port also helped to change their opinion about the shape of the earth, that is, usually they see smoke of the ship first and then the top of the ship after that the whole ship.
4. Observations about the movement of stars and different stars visible from different places on the earth also helped to think about the shape of the earth.

Through all such observations made by so many people at so many places on the earth they came to an understanding that earth is spherical. And then it is get clarified in 1969 when man landed on the moon and

observed the earth's shape from the moon.

11.8 How did people come to an understanding that earth rotates on its own axis?

People from olden days thought that earth is located in the center of the universe with sun, moon and stars moving around it. They also thought that sun, moon and stars are located on transparent concentric spheres surrounding the earth, because they are not falling down. The three spheres are rotating on their axis from east to west that is why sun, moon and stars appear to revolve from east to west around the earth. They also assumed that the sphere on which sun is located rotates east to west and oscillates from south to north that is why uttarayanam and dakshinayanam are happening.

Because of the uneven movement of some stars (actually they are planets) which they observed, it became very difficult to explain the model of universe which required so many transparent spheres around the earth. Nicholas Copernicus suggested that the sun is at the center of the universe and all other celestial objects are revolving around the sun. Then how do day and nights occur.

It was assumed that earth rotates on its axis. This model could explain the occurrence of day and night.



Key words

Celestial bodies, Local noon, Sundial, Uttarayanam, Dakshinayanam, Phases of the moon, Constellation, Galaxy, Pole star, Solar system, Planets, Satellites, Artificial satellites, Asteroids, Comets, Meteors, Meteorite.



What we have learnt?

- The shortest shadow cast by a vertical object on the ground always falls in North, South direction.
- The shortest shadow of an object occurs at local noon.
- The time duration for appearance of sun and moon after completion of a cycle is different.
- Changes in appearance of moon are called phases of the moon.
- On the new moon day, sun and moon are on the same side of the earth.
- On the full moon day, sun and moon are on either sides of the earth.
- Moon has no atmosphere like we have on the earth.
- The polestar is situated in the direction of the earth's axis and hence it appears as not moving.
- There are eight planets in our solar system.
- Among eight planets of solar system earth is the only planet which supports life.
- Large number of objects that revolve around the sun between the orbits of Mars and Jupiter are asteroids.
- The length of the tail of the comet grows in size as it approaches the sun.
- A meteor is a small object that occasionally enters the earth's atmosphere.
- A body that reaches the earth is called a meteorite.
- Aryabhatta was the first Indian artificial satellite.
- Forecasting weather, transmitting Television and Radio signals, Telecommunication, remote sensing are the practical applications of artificial satellites.



Improve your learning



I. Reflections on concepts

1. Why does pole star seem to be stationary? (AS₁)
2. Among all 8 planets what is the special thing about earth? (AS₁)

3. How do people come to an understanding that earth is spherical? (AS₁)
4. How do people come to an understanding that earth rotates on its own axis? (AS₁)

II. Application of concepts

1. What factors to be taken into consideration to view the pole star at your place? (AS₁)
2. How can you find north – south direction at your place? (AS₃)
3. Is it possible to see the pole star for the people who live in the southern hemisphere of the earth? Why? (AS₁)
4. Draw the different phases of moon. Arrange them in a order from pournami to amavasya. (AS₅)
5. What are the planets you have seen in the sky? When do you observe those planets? (AS₁)
6. What are the uses of artificial satellites in our daily life? (AS₇)
7. How do day and night occur? (AS₁)

III. Higher Order Thinking Questions

1. Even though we do not have clock, we can know the time by observing some shadows in day time. Think and discuss with your friends how can we know the time at night. (AS₂)
2. We launched many artificial satellites around our earth for different purposes. What do you think about the impact of artificial satellites and their radiation on bio diversity? (AS₇)



Multiple Choice Questions

1. When the moon completely covers the sun as seen from the earth is known as...

a) Partial solar eclipse	b) Total solar eclipse	()
c) Annular eclipse	d) Hybrid eclipse	
2. The planet which is near to earth is ()

a) Mercury	b) Venus	c) Jupiter	d) Saturn
------------	----------	------------	-----------
3. The brightest planet among all the planets ()

a) Mercury	b) Venus	c) Jupiter	d) Saturn
------------	----------	------------	-----------

4. Moon is ()
a) the natural satellite to earth b) an artificial satellite to earth
c) a comet d) an asteroid
5. The first Indian artificial satellite ()
a) INSAT b) Kalpana-I c) Aryabhata d) EDUSAT

Experiments

1. Conduct an experiment to find out the “local noon time” of your village/Town.
2. Conduct an experiment to make a sundial and write a report.



Project Works

1. Collect the information what the Chandrayaan-1 brought the information from the Moon from news papers, magazines etc.
2. Collect information about cosmic dust (wastage) from news papers, internet. Make a poster about the consequences of cosmic dust.
3. What is the duration of a day and night today? Collect the information about duration of day and night for the past 7 days from the news papers, analyze it and say whether summer or winter is going to come.
4. Collect the information about Chandrayaan-2 and write a report.



In class 7, We studied about motion, types of motion and relation between speed, distance and time.

- Can we describe motion by using graphs?

Let us try with some situations.

Have you travelled in a bus or train or bullock cart or auto? Try to recall a trip you made and answer the following questions.

- Where did you begin your journey from and where did you go?
- What was the distance between these two places?
- How long did it take for you to make the trip?
- What was the average distance your vehicle (bus or train or bullock cart or auto) travelled in one hour?

The distance travelled by an object in a unit of time (hour, minute, second etc.) is called the **average speed** of the object. The equation to calculate the average speed is

$$\text{Average Speed} = \frac{\text{Total distance travelled}}{\text{Total time taken to cover the distance}}$$

If we measure the distance in kilometers and the time in hours, the unit of speed will be kilometer per hour or KMPH. We can use other units of distance and time to measure the speed.

- Can we guess the unit of speed if the distance covered is measured in centimeters and the time in seconds?
- What will the unit of speed be if the distance covered is measured in meters and the time in minutes?
- Raja travelled 15 kilometers in 3 hours. Calculate his average speed and write the correct unit of speed.

Note: It is important to mention the unit when we denote any quantity like distance, time, speed, weight etc. Otherwise it becomes meaningless. So always remember to write the unit after the quantity that you denote.

There are many different ways in which you can describe a journey. In this chapter we shall learn how to use graphs to describe and represent motion. We shall also see in what other ways graphs of motion can be useful to us.

Activity-1

Swathi walked from her home to her school. The details of her journey are given in table - 1.

Table - 1

TIME (in minutes)	Distance Travelled (in meters)
0-2 (first two minutes)	120
2-4 (second two minutes)	120
4-6 (third two minutes)	120
6-8 (fourth two minutes)	120
8-10 (fifth two minutes)	120
10-12 (sixth two minutes)	120

This data tells us the distance Swathi walked in consecutive two - minute segments of her journey but it doesn't tell us how far she walked at any given time of her journey, for example say after 10-minutes. So, we can not find the distance from her home to her school just by looking at a table. To get this information, we must present the data in the table in a different way. We must show the total elapsed time and the total distance covered (table-2).

Table - 2

Total elapsed time (in minutes)	Total distance covered (in meters)
2	120
4	240
6	360
8	480
10	600
12	720

Let us now use this data to make a graph of Swathi's journey, showing the time taken and the distance covered.

You have learnt how to make graphs in mathematics. For this graph we shall show the time on X-axis, and distance covered on Y-axis. Draw the X and Y axes on your graph paper and choose a scale for each axis. Record the scale in the upper right hand corner of your graph paper.

To represent the data given in table - 2 as a graph, mark the first point on the graph which corresponds to a time of two minutes on the X-axis and a distance of 120 meters on the Y-axis. In the same way, plot the remaining five points on graph paper. Connect these points with the help of a ruler to get a straight line.

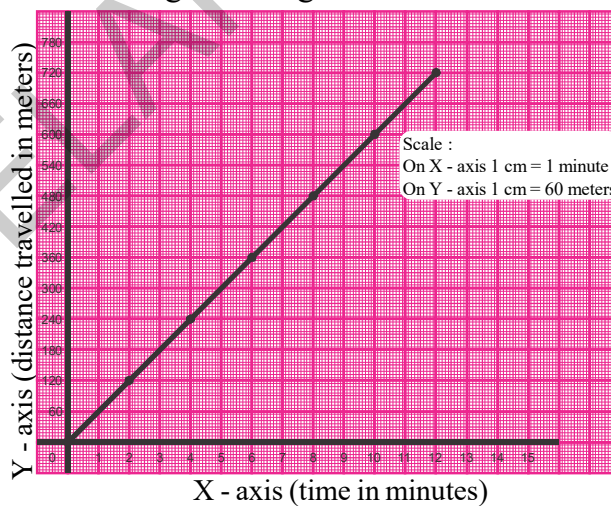

GRAPH - 1

This graph shows swathi's journey from her home to school.



Think and Discuss

- Why should we take time on X-axis and distance covered on Y-axis

A graph is not a map

You must remember that the graph you have drawn and the other graphs you will draw in this chapter are graphs that are

plotted time elapsed against the distance covered. They are not maps showing the route of journey. Never make a mistake of thinking that a graph shows route of the journey.

Figure -1 is a map showing the road from Swathi's house to school. Swathi walks to school along this road. Compare the graph that shows Swathi's journey (graph -1) and the map. (Figure - 1)

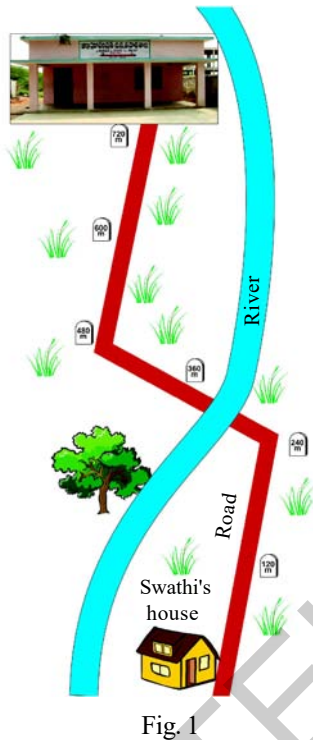

- Can you estimate how long Swathi takes to reach her school by looking at the map?
- Can we guess how many turns are there along the road from Swathi's home to her school, or where the road crosses the river, by looking at the graph?

It is evident that the information you get from a route map can not be obtained from a graph. Similarly, information about the speed at which Swathi walked can be obtained only from the graph, not from the map.

- Did Swathi cover an equal distance in every two minutes interval of her journey?

If an object covers an equal distance in equal time intervals it is said to be in "*uniform motion*".

- How would the graph of time and distance look for an object travelling with uniform motion?

If an object is travelling with uniform motion, the distance it covers in a unit of time is its speed.

- What was Swathi's speed for each two minute segment of her journey.
- Calculate the average speed of Swathi's complete journey and write in your notebook.
- Is the speed for each two minutes segment the same as her average speed for the entire journey?

The speed of an object which is in uniform motion does not change. in such cases the speed and average speed are the same.

Activity-2

Graphs of objects moving at different uniform speeds

Anish and Hitesh raced from their home to school. Hitesh ran at uniform speed, so did Anish. But their uniform speeds were different. Graph - 2 shows their motions.

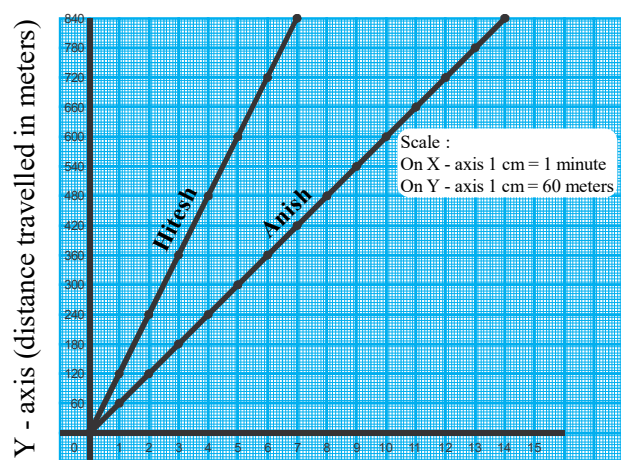

X - axis (time in minutes)

GRAPH-2

- Can you tell who ran faster just by looking at the graph?
- How much time did Hitesh take to run from home to school?
- Calculate his average speed.
- What was the average speed of Anish?

Relation between speed and the slope of a graph

If we have two graphs of uniform speed, we just by looking at the two lines can tell which speed is greater. We should look at the angle that the two graph lines make with the X-axis. We can estimate the slope of the graph lines from these angles. The greater the angle, the greater the slope for graph line.

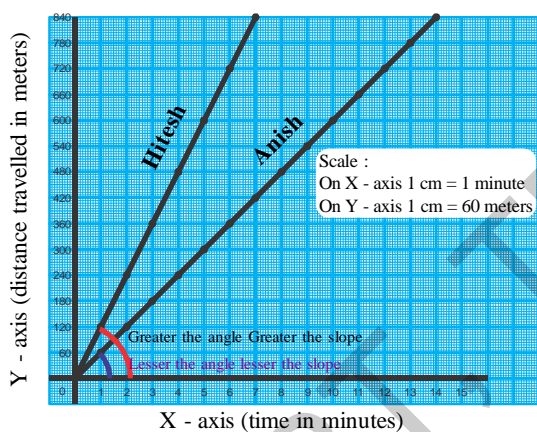

GRAPH - 3

- Take another look on graph - 3. Which graph line has the greater slope - Hitesh's or Anish's?
- Is his speed faster too?

Any graph of uniform motion will be a straight line. The faster the speed of uniform motion the greater will be the slope of the graph line (graph-3). That is, the angle that graph line makes with the X-axis will be larger. But remember you can make such visual comparisons only between graphs which have the same scale. You can not compare graphs with different scales just by looking at them.

Activity-3

Graphs of stationary objects.

Bhoomika went to a journey and the data of her trip is given in table - 3.

Table - 3

Time (in minutes)	Distance Travelled (in meters)
0-2	60
2-4	60
4-6	60
6-8	0
8-10	0
10-12	0
12-14	60
14-16	60

- Can you say by looking at the table whether Bhoomika rested some where during her journey?
- After walking how many minutes did Bhoomika take rest? For how many minutes did she take rest?
- How would you show the duration of her rest in a graph?

To understand how this is to be done, let us draw a graph of Bhoomika's journey. But before we do this we must rearrange the figures in table - 3 and write them in table 4 as shown below.

Table - 4

Time (in minutes)	Distance Travelled (in meters)
2	60
4	120
6	-
8	-
10	-
12	-
14	-
16	-

Activity-4

The graph of Sana's journey is given in graph 4.

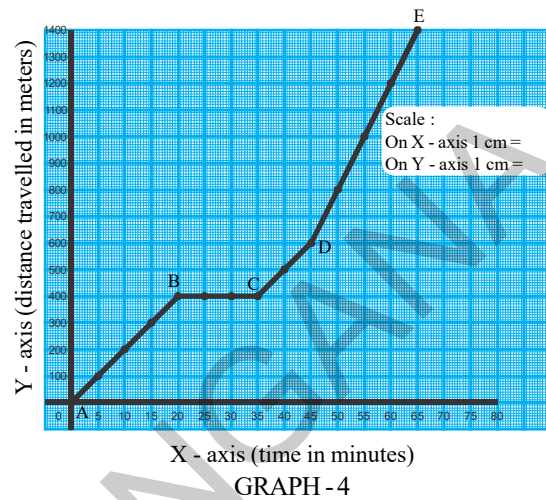

Look at the graph and answer the following questions.

- Copy table -4 in your exercise book and fill the blanks.
 - Use the data from table-4 to draw a graph of Bhoomika's journey.
 - Look at the graph and estimate the distance covered by Bhoomika after 8 minutes.
 - How far did she travel after 12 minutes?
- From the 8th to 12th minutes of her journey, the time increased but the total distance covered remained same.
- When any object stops at a place, the time continues to increase but the distance covered does not change during its journey. Then the graph line remains parallel to the X-axis. This shows that the object is at rest.
- What is the scale for X-axis?
 - What is the scale for Y-axis?
 - What was Sana's average speed for section AB of her journey?
 - What was her average speed for section CD of her journey?
 - Calculate Sana's average speed for her entire journey.
 - After covering what distance did Sana take rest and for how long did she take rest?
 - Which section of the graph has a greater slope AB or CD?

Activity-5

Graphs of non uniform motion

We have learnt about graphs of uniform motion in the activities that we have done so far. We shall now look at graphs of motions which are not uniform.

For example, observe the motion of a train leaving or arriving at a station.

- Is the motion of the train uniform when it leaves the station?
- What changes took place in the motion of the train when it comes to a halt at a station.

The motion in which there is an increase or a decrease in speed is called a non-uniform motion.

Abhilash travelled by a train from Khammam to Secunderabad. He estimated the distance covered for each 30 minutes interval by counting the telephone poles along the railway track. He noted this estimated distances in the form of a graph. Graph-5 shows the motion of the train starting from when it left Khammam station till it stopped at Secunderabad station.

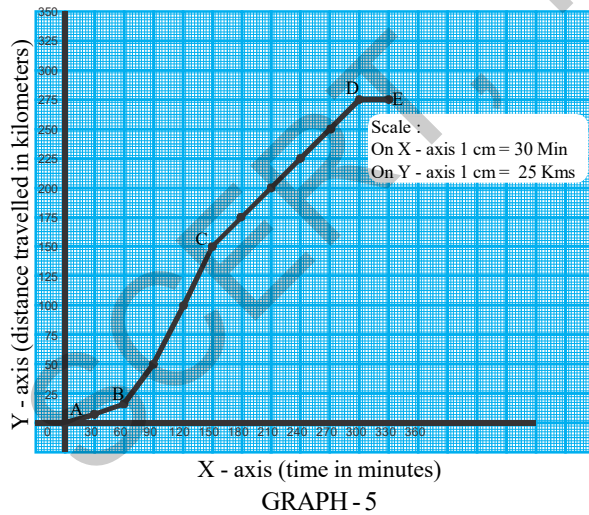

- Find the distance covered by the train for every 30 minutes interval of time by observing the graph and note the values in table-5.

Table - 5

Time (in minutes)	Distance covered (in kilometers)
0-30	10
30-60	20
60-90	30
.....
.....
.....
.....
.....
.....
.....
300-330	250

- Did the train cover equal distances in equal intervals of time?
- Which section of the graph shows non uniform motion of the train?
- Which section of the graph shows uniform motion of the train?
- In which section of the graph was the train at rest?
- Observe at the sections of non uniform and uniform motion of the train in the graph. What prime difference do you notice between these two sections?

A curved line in the graph of motion represents that the speed is changing continuously. Observe section AB of the graph. It shows the gradual increase in train's speed when it leaves Khammam station.

Activity-6

Graph showing the motion of a turtle in turtle-swan story

You might have heard about the story of the flight of the turtle. In this story two swans carry their friend turtle by holding the two ends of a stick firmly in their beaks and with the turtle gripped on the middle of the stick with its teeth. The swans flew at about high 180 meters and carry the

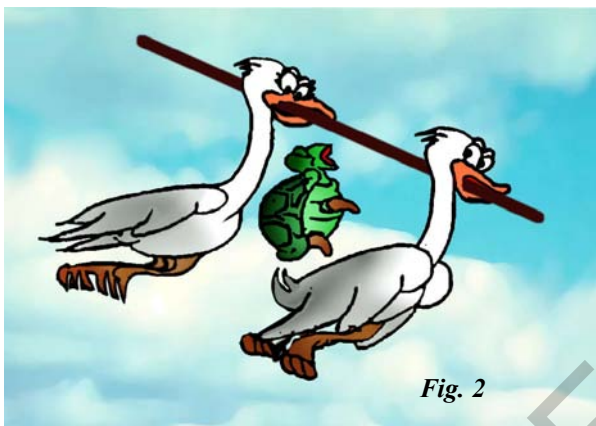

Fig. 2

As they were flying above a lake the turtle was overwhelmed by the beautiful scene below. He could not hold his excitement and exclaimed "Wow!". The remaining part of the story of the turtle's flight of falling down is given in table-6.

Table - 6

Time (in seconds)	Distance Turtle fell (in meters)
1	5
2	20
3	45
4	80
5	125
6	180

- Draw a graph of motion of the turtle's fall.

- What does the graph look like? What is the shape of the graph?
- Can you guess whether the motion of the turtle is uniform or non-uniform based on the graph?
- How much time did the turtle take to fall in to the lake from a height of 180 meters?
- What was the average speed of the turtle during its fall?

Activity-7

Anitha riding a bicycle

Let us assume you are riding a bicycle. You don't have any problem in pedalling on the plane road with uniform motion. But when you are pedalling on a slant road against uphill, it gets difficult and your speed decreases. On other hand, when you go along the slope, your speed increases and the bicycle moves really fast.



Fig. 3

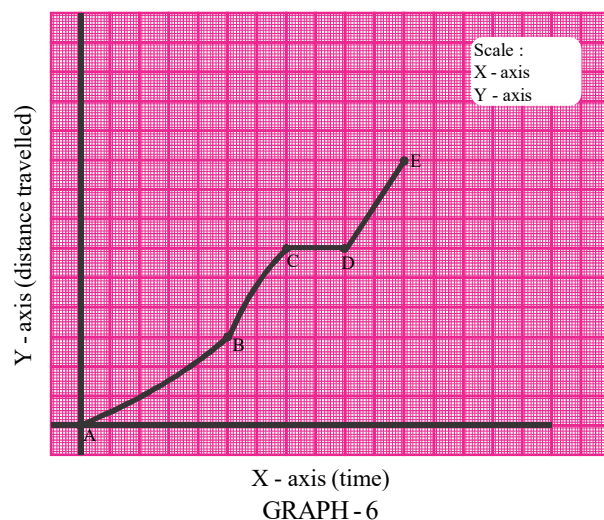

Graph-6 shows the motion of bicycle due to the pedalling made by Anitha. Look at the graph and state which of the following statements are true.

- Anitha cycled down the slope for some time and then cycled against the slope then took rest for a while and then cycled on a plane road.
- Anitha is pedalling the bicycle on uphill road continuously.
- Anitha first went downhill, then on a plane road, then uphill and finally rested.
- Anitha first cycled up hill, then stoped and rested for some time because she was tired, then cycled on a level road and finally rode downhill.

Activity-8

Ajay set out from his village walking at a speed of 4 kmph. After walking for two hours he rested under the shade of a tree. An hour later he again began walking at a speed of 3 kmph. After walking for 2 hours he met his friend Rajesh. They sat under a tree talking for one-and-a-half hours. Then Rajesh took Ajay on his bicycle at a speed of 10 kmph. They cycled for one-and-a-half hours before reaching the city.

Let us proceed step by step to draw a graph of Ajay's journey.

First we shall make a table of the distance he travelled in different time intervals. For example in the first two hours he walked at a speed of 4 kmph that means he cover a distance of $2 \times 4 = 8$ km. In the same way the distances he travelled in the remaining time intervals are as follows.

- Ajay rested under a tree for an hour. So the distance travelled in this time was _____ km.
- In the next two hours he walked at a speed of 3 kmph. So the distance he travelled in these two hours was _____ km.
- In the next one-and-a-half hours he sat and talked with his friend. So the distance he travelled was _____ km.
- Finally in the next one-and-a-half hours he travelled on his friend's bicycle at a speed of 10 kmph and reached the city. in this one-and-a-half hours he covered a distance of _____ km.

Enter this data in table 7.

Table - 7

Time (in hours)	Distance covered (in kilometers)
2	8
1	_____
2	_____
1.5 (1 hour 30 min)	_____
1.5 (1 hour 30 min)	_____

Make a table (table-8) on the basis of table-7. It should contain the total elapsed time and the total distance covered.

Table - 8

Time Elapsed (in hours)	Distance covered (in kilometers)
0	_____
2	_____
3	_____
5	_____
6.5 (6 hours 30 min)	_____
8	_____

Draw a graph for Ajay's journey with the data given in the table. Answer the following questions on the basis of this graph.

- After walking how many kilometers did Ajay meet Rajesh?
- How many hours did Ajay take to reach the city from his village?
- What was average speed of Ajay's for the first five hours?
- What is the distance between the village of Ajay and the city?
- Which section of the graph has the maximum slope?

Activity-9

Raizee and Jessika decided to visit a sweet shop after school. When they were about to leave the school, the teacher called Jessika. So Raizee left alone. After a short while Jessika came running and joined with Raizee. Then they went together to the sweet shop and ate sweets there. The entire episode is shown below in the form of a graph (graph-7). Their journeys are shown by separate graph lines marked with different colours.

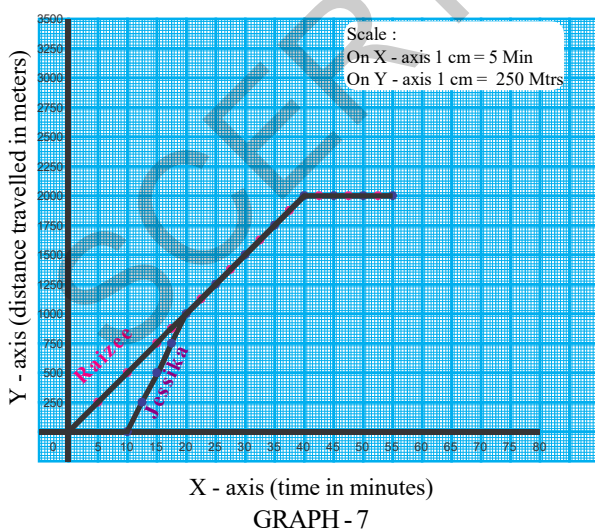

Now look at the graph and answer the following questions.

- What was Raizee's speed per minute?
- For how long was Jessika detained by her teacher?
- For how long did Jessika run before she joined with Raizee?
- What was Jessika's Average speed per minute while she ran?
- At what distance from the school did Jessika joined with Raizee?
- What distance did the two cover together?
- For how much duration did they walk together?

Activity-10

A brain teaser

When school was over, Mounika and Divya left for their homes. Mounika's house lay to the east of the school while Divya's house lay to the west. The graph of their journey to their homes is shown in graph - 8. Look at the graph and answer the following questions.

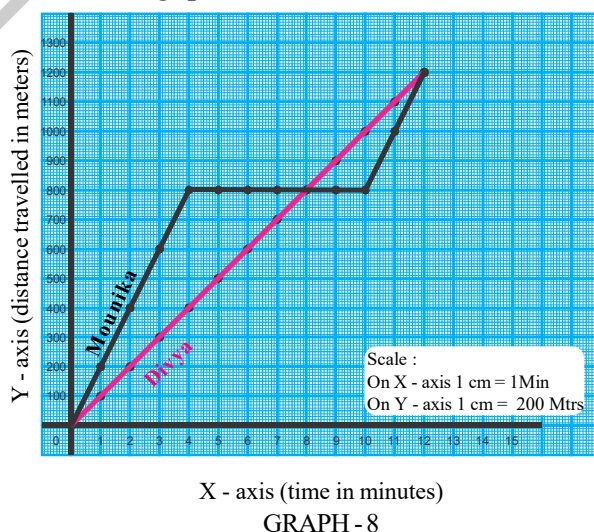

- Did Mounika walk with uniform motion throughout her journey?
- How far is Mounika's home from the school?
- How far is Divya's home from the school?
- How much time did Mounika take to reach her home?

- How much time did Divya take to reach her home?
- Did Divya stop on the way? For how much time did she stop?
- Calculate Divya's average speed during her journey.
- Did Mounika halt anywhere? How much time did she stop?
- Calculate Mounika's average speed during her journey.

Activity-11

The graph of a story

This is a very old story. You may have heard it many times before. It is the story of a race between the rabbit and the tortoise. The two take a bet on who will win the race. The rabbit takes off swiftly while the tortoise begins at a slow and steady pace. The rabbit runs far ahead, then halts to rest under a tree for a while. He falls asleep.

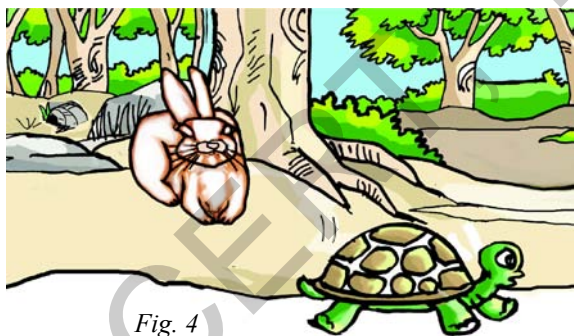

Fig. 4

The tortoise, meanwhile, continues to forge ahead steadily. When the rabbit awakes, he runs swiftly to the finishing post. But alas! when he reaches the finishing line he finds that the tortoise has already won the race.

Illustrate the race between the rabbit and the tortoise in the form of a graph.



Key words

Motion, Speed, Uniform motion, Non-uniform motion, Average speed, Slope.



What we have learnt?

- Average speed = $\frac{\text{Total distance travelled}}{\text{Total time to cover the distance}}$
- If an object covers equal distances in equal intervals of time then the motion is said to be uniform motion.
- Different types of motions can be represented by time-distance graphs.
- Time-Distance graph of uniform motion is a straight line.
- As the angle made by the graph with X-axis increases, slope increases.
- Motion in which the speed increases or decreases is called non uniform motion.
- Time-Distance graph of a non-uniform motion is not a straight line rather it is a curve.
- Slope of the time-distance graph line shows the speed of the object at that time.
- If an object is at rest then the time distance graph is a line parallel to X-axis.



Improve your learning

I. Reflections on concepts

1. Look at Graph-9.



Which section of graph 9 has the greatest slope? What can you say about the speed in this section? What can you say about the speed in section CD of the graph. (AS₄)

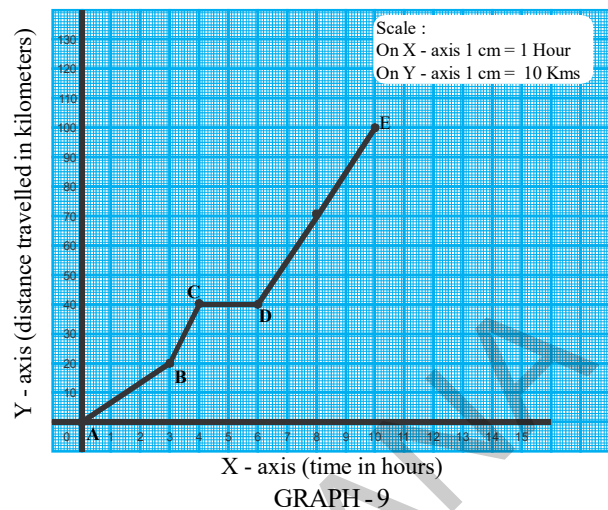

II. Application of concepts

1. A river is 32 kms away from Nikitha's house. There is a hillock on the way. Nikitha left for the river one morning on her bicycle. She reached the hillock after 2 hours, pedalling at a speed of 5 kmph. Since she could not cycle up the slope, she continued on foot, walking for an hour at a speed of 3 kmph, and reached the top of the hillock. From there the road was all downhill. She rode her bicycle at a speed of 18 kmph and reached the bottom of the hillock in half-an-hour. She then rested under a tree for half an hour. Refreshed after a rest, she cycled at a speed of 5 kmph and reached the river in 2 hours.

Draw a graph of Nikitha's journey from her home to the river. (AS₄)

2. Sunitha and her brother Bharat studying in the same school. Sunitha walks to the school while Bharath cycles to the school. So, Sunitha has to leave an hour before Bharath to reach the school on time. Graph 10 shows the graph lines of their journey from their home to the school. Look at the graph and answer the following questions. (AS₄)

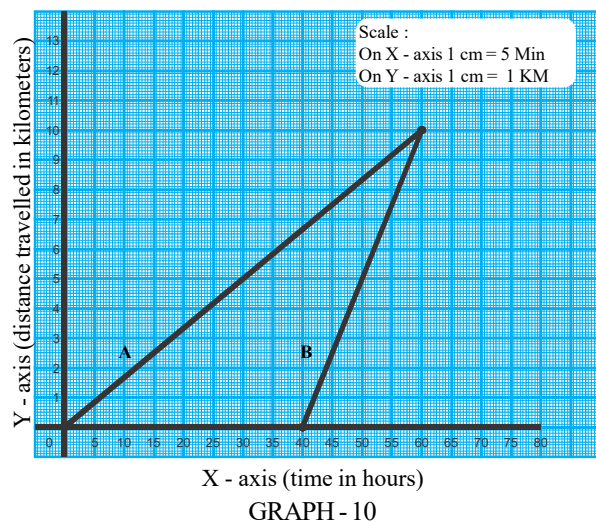

- A) Which graph line shows Sunitha's journey?
- B) Whose graph line has a greater slope?
- C) Whose speed is greater?
- D) If Sunitha wants to reach school in 3 hours at what speed should she walk?

III. Higher order thinking questions

1. Graph-11 shows the journey of Rakesh and Share Khan. Write a story about their journey on the basis of the graph? (AS₄)

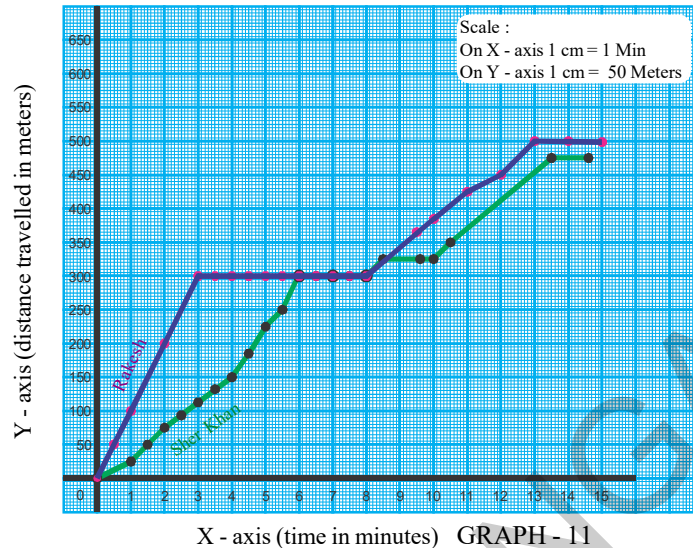

Multiple Choice Questions

1. What does the slope on a distance versus time graph represent? ()

a) Displacement b) Speed c) Velocity d) Acceleration

2. Which of the following graph represents constant speed (or) uniform motion ()

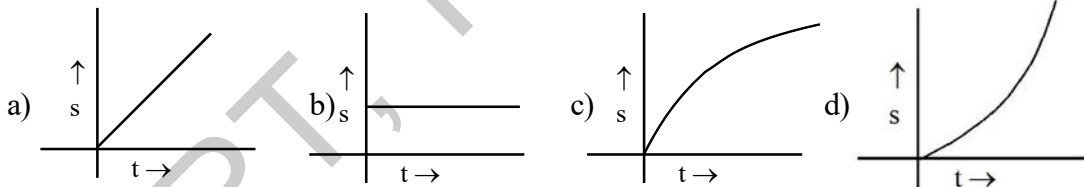

3. The distance - time graphs of four vehicles 1, 2, 3 and 4 are given in the adjacent figure. Which of them has greater speed? ()

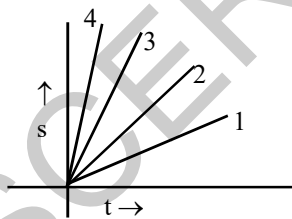

a) 2 b) 3 c) 1 d) 4

4. The given below distance - time graph represents the motion of a cart. During in which interval the cart is at rest? ()

a) AB b) DE c) BC d) CD

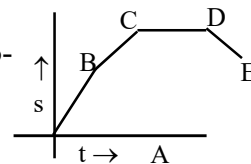

5. According to graph, as time increases, the speed of the object ()

a) Increases b) decreases
c) remains same d) we cannot say

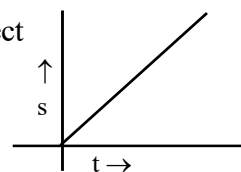

Dear students...

Learning science does not mean scoring good marks in the subject. Competencies like thinking logically and working systematically, learned through it, have to be practiced in daily life. To achieve this, instead of memorizing the scientific theories by rote, one must be able to study them analytically. That means, in order to understand the concepts of science, you need to proceed by discussing, describing, conducting experiments to verify, making observations, confirming with your own ideas and drawing conclusions. This text helps you to learn in that way.

What you need to do to achieve such things:

- Thoroughly go through each lesson before the teacher actually deals with it.
- Note down the points you came across so that you can grasp the lesson better.
- Think of the principles in the lesson. Identify the concepts you need to know further, to understand the lesson in depth.
- Do not hesitate to discuss analytically about the questions given under the sub-heading 'Think and Discuss' with your friends or teachers.
- You may get some doubts while conducting an experiment or discussing about a lesson. Express them freely and clearly.
- Plan to implement experiment/lab periods together with teachers, to understand the concepts clearly. While learning through the experiments you may come to know many more things.
- Find out alternatives based on your own thoughts.
- Relate each lesson to daily life situations.

- Observe how each lesson is helpful to conserve nature. Try to do so.
- Work as a group during interviews and field trips. Preparing reports and displaying them is a must.
- List out the observations regarding each lesson to be carried through internet, school library and laboratory.
- Whether in note book or exams, write analytically, expressing your own opinions.
- Read books related to your text book, as many as you can.
- You participate in the Science Club programs in your school.
- Observe problems faced by the people in your locality and find out what solutions you can suggest through your science classroom.
- Discuss the things you learned in your science class with farmers, artisans *etc.*

Dear teachers...

New Science Text Books are prepared in such a way that they develop children's observation power and research enthusiasm. It is a primary duty of teachers to devise teaching- learning processes which arouse children's natural interest of learning things. The official documents of National & State Curriculum Frameworks and Right to Education Act are aspiring to bring grass root changes in science teaching. These textbooks are adopted in accordance with such an aspiration. Hence, science teachers need to adapt to the new approach in their teaching. In view of this, let us observe certain **Dos** and **Don'ts**:

- Read the whole text book and analyze each and every concept in it in depth.
- Develop activities for children which help them to understand concepts presented in text.
- Textual concepts are presented in two ways: one as the classroom teaching and the other as the laboratory performance.
- Lab activities are part and parcel of a lesson. Teachers must make the children conduct all such activities during the lesson itself, but not separately.
- Children have to be instructed to follow scientific steps while performing lab activities and relevant reports can be prepared and displayed.
- In the text some special activities as boxed items- 'think and discuss, let us do, conduct interview, prepare report, display in wall magazine, participate in Theatre Day, do field observation, organize special days' are presented. To perform all of them is compulsory.
- 'Ask your teacher, collect information from library or internet'- such items must also be considered as compulsory.

- If any concept from any other subject got into this text, the concerned subject teacher has to be invited into the classroom to elucidate it.
- Collect info of relevant website addresses and pass on to students so that they can utilize internet services for learning science.
- Let there be science magazines and science books in the school library.
- Motivate every student to go through each lesson before it is being actually taught and encourage everyone to understand and learn independently, with the help of activities such as Mind Mapping and exciting discussions.
- Plan and execute activities like science club, elocution, drawing, writing poetry on science, making models *etc.* to develop positive attitude among children environment, biodiversity, ecological balance *etc.*
- As a part of continuous comprehensive evaluation, observe and record children's learning abilities during various activities conducted in classroom, laboratory and field.

We believe, you must have realized that the learning of science and scientific thinking are not mere drilling of the lessons but, in fact, a valuable exercise in motivating the children to explore solutions to problems all around by themselves systematically and preparing them to meet life challenges properly.

INSPIRE AWARDS

Inspire is a National level programme to strengthen the roots of our traditional and technological development.



The major aims of Innovations in Science Pursuit for Inspired Research (INSPIRE) programme are...

- Attract intelligent students towards sciences
- Identifying intelligent students and encourage them to study science from early age
- Develop complex human resources to promote scientific, technological development and research

Inspire is a competitive examination. It is an innovative programme to make younger generation learn science interestingly. In 11th five year plan nearly Ten Lakhs of students were selected during 12th five year plan (2012-17) Twenty Lakhs of students will be selected under this programme.

Two students from each high school (One student from 6 - 8 classes and one from 9 - 10 classes) and one student from each upper primary school are selected for this award.

Each selected student is awarded with Rs. 5000/-. One should utilize 50% of amount for making project or model remaining for display at district level Inspire programme. Selected students will be sent to State level as well as National level.

Participate in Inspire programme - Develop our country.

LEARNING OUTCOMES

PHYSICAL SCIENCES

CLASS 8

The learner....

- Differentiates materials such as
(i) Natural and human made fibres (ii) Contact and Non-contact forces
(iii) Liquids as electrical conductors and insulators.
- Classifies materials based on properties and characteristics.
(i) Metals and non-metals (ii) Celestial objects (iii) Exhaustible and Inexhaustible natural resources.
- Conducts simple investigation to seek answers to queries
Ex (i) What are the conditions required for combustion?
- Relates processes and phenomenon with causes
Ex (i) Reflection of light.
(ii) Petroleum products- Separation.
- Explains processes and phenomenon
Ex (i) Production and propagation of sound
(ii) Chemical effects of electrical current
(iii) Structure of flame
- Writes word equations for chemical reactions
(i) Reactions of metals and non-metals with air, water and acids etc.
- Measures angles of incident and reflection
- Draws labeled diagram, flow charts (i) Ray Diagram (ii) Experimental setups.
- Constructs models using materials from surroundings and explains their working.
Eg (i) Jaltarang (ii) Sitar (iii) Electroscope (iv) Fire extinguisher
- Applies learning of scientific concepts in day-to-day life
Ex (i) Purifying water (ii) Segregating biodegradable and non biodegradable waste
(iii) Increasing / reducing friction
- Discuss and appreciates stories of scientific discoveries.
- Makes efforts to protect environment
Ex: (i) Using resources (like plastic) judiciously
(ii) Suggesting ways to cope with environmental hazards etc.
- Exhibits creativity in designing planning, making use of available resources etc.
- Exhibits values of honesty, objectivity, cooperation freedom from fear and prejudices.



विद्यया ऽ मृतमश्नुते
विद्यया ऽ मृतमश्नुते
विद्यया ऽ मृतमश्नुते

विद्यया ऽ मृतमश्नुते



एन सी ई आर टी
NCERT



ACADEMIC STANDARDS

S.No.	Academic Standard	Explanation
1.	Conceptual understanding	Children are able to explain, cite examples, give reasons, and give comparison and differences, explain the process of given concepts in the textbook. Children are able to develop their own brain mappings.
2.	Asking questions and making hypothesis	Children are able to ask questions to understand concepts, to clarify doubts about the concepts and to participate in discussions. They are able to guess the results of an issue with proper reasoning, able to predict the results of experiments.
3.	Experimentation and field investigation.	Children are able to do the experiments given in the text book and developed on their own. Able to arrange the apparatus, record the observational findings, suggest alternative apparatus, takes necessary precautions while doing the experiments, able to do to alternate experiments by changing variables. They are able to participate in field investigation and prepare reports.
4.	Information skills and Projects	Children are able to collect information related to the concepts given in the text book by using various methods (interviews, checklist questionnaire) analyse the information and interpret it. Able to conduct project works.
5.	Communication through drawing, model making	Children are able to communicate their conceptual understanding by the way of drawing pictures labelling the parts of the diagram by drawing graphs, flow charts and making models.
6.	Appreciation and aesthetic sense, values	Children are able to appreciate the nature and efforts of scientists and human beings in the development of science and have aesthetic sense towards nature. They are also able to follow constitutional values.
7.	Application to daily life, concern to bio diversity.	Children are able to apply the knowledge of scientific concept they learned, to solve the problem faced in daily life situations. Recognise the importance of biodiversity and takes measures to protect the biodiversity.

Text Book Development Committee

Sri A. Satyanarayana Reddy, Director,
S.C.E.R.T., Hyderabad

Sri B. Sudhakar, Director,
Govt. Textbook printing press,
Hyderabad.

Dr.N. Upendar Reddy,
Professor & Head C&T Dept.,
S.C.E.R.T., Hyderabad.

Writers

Dr. P. Shankar, Asst. Professor,
IASE, O.U., Hyderabad.

Sri M. Ramabrahmam, Lecturer,
Govt. IASE, Masabtank, Hyderabad.

Dr. K. Suresh, SA,
ZPHS Pasaragonda, Warangal.

Sri R. Ananda Kumar, SA,
ZPHS Laxmipuram, Visakhapatnam.

Sri Dr. S. Anjaneyulu, SA,
ZPHS Veeraballi, YSR Kadapa.

Sri K.V.K. Srikanth, SA,
GTWAHS S.L.Puram, Srikakulam.

Sri A. Nagaraja Sekhar, SA,
ZPHS, Chatakonda, Bhadradi Kothagudam.

Sri M. Eswara Rao, SA,
GHS Sompeta, Srikakulam.

Sri D. Madhusudhana Reddy, SA,
ZPHS Munagala, Nalgonda.

Sri Y. Guru Prasad, SA,
ZPHS Chinnacherukuru, Nellore.

Sri C.V. Harikrishna, SA,
ZPHS, Cheru Annaram, Nalgonda.

Sri K.L. Ganesh, SA,
ZPHS M.D.Mangalam, Chittoor.

Sri Y. Venkat Reddy, SA,
ZPHS Kudakuda, Nalgonda.

Graphics & Designing

Sri K. Sudhakara Chary, SGT,
UPS Neelukurthy, Warangal.

Sri Kishan Thatoju, Computer Operator,
C&T Dept., SCERT, Hyderabad.

Sri Kurra Suresh Babu, B.Tech., MA., MPhil
Mana Media Graphics, Hyderabad.

Sri Md. Ayyub Ahmed, S.A.,
Z.P. H.S U/M, Atmakur, Mahbubnagar.

Editors

Prof. Kamal Mahendroo,
Vidya Bhawan Education Resource Centre,
Udaipur, Rajasthan.

Dr.B. Krishna rajulu Naidu,
Retd., Professor of Physics
Osmania University, Hyderabad.

Dr.M. Adinarayana,
Retd., Professor of Chemistry
Osmania University, Hyderabad.

Dr. Nannuru Upendar Reddy,
Professor & Head C&T Dept.,
SCERT., Hyderabad.

Academic Support

Prof. V. Sudhakar
Dept of Education, EFLU, Hyderabad.

Miss. Preeti Misra,
Vidya Bhawan Education Resource Centre,
Udaipur, Rajasthan.

Mr Kishore Darak,
Vidya Bhawan Education Resource Centre,
Udaipur, Rajasthan.

Co-ordinators

Sri M. Ramabrahmam, Lecturer,
Govt. IASE, Masabtank, Hyderabad.

Dr. P. Shankar, Asst. Professor,
IASE, O.U., Hyderabad.

Dr. TVS Ramesh,
Co-ordinator, C&T Dept.,
SCERT, Hyderabad.

QR CODE TEAM

