



The laws of nature are but the mathematical thoughts of God.

EUCLID

10

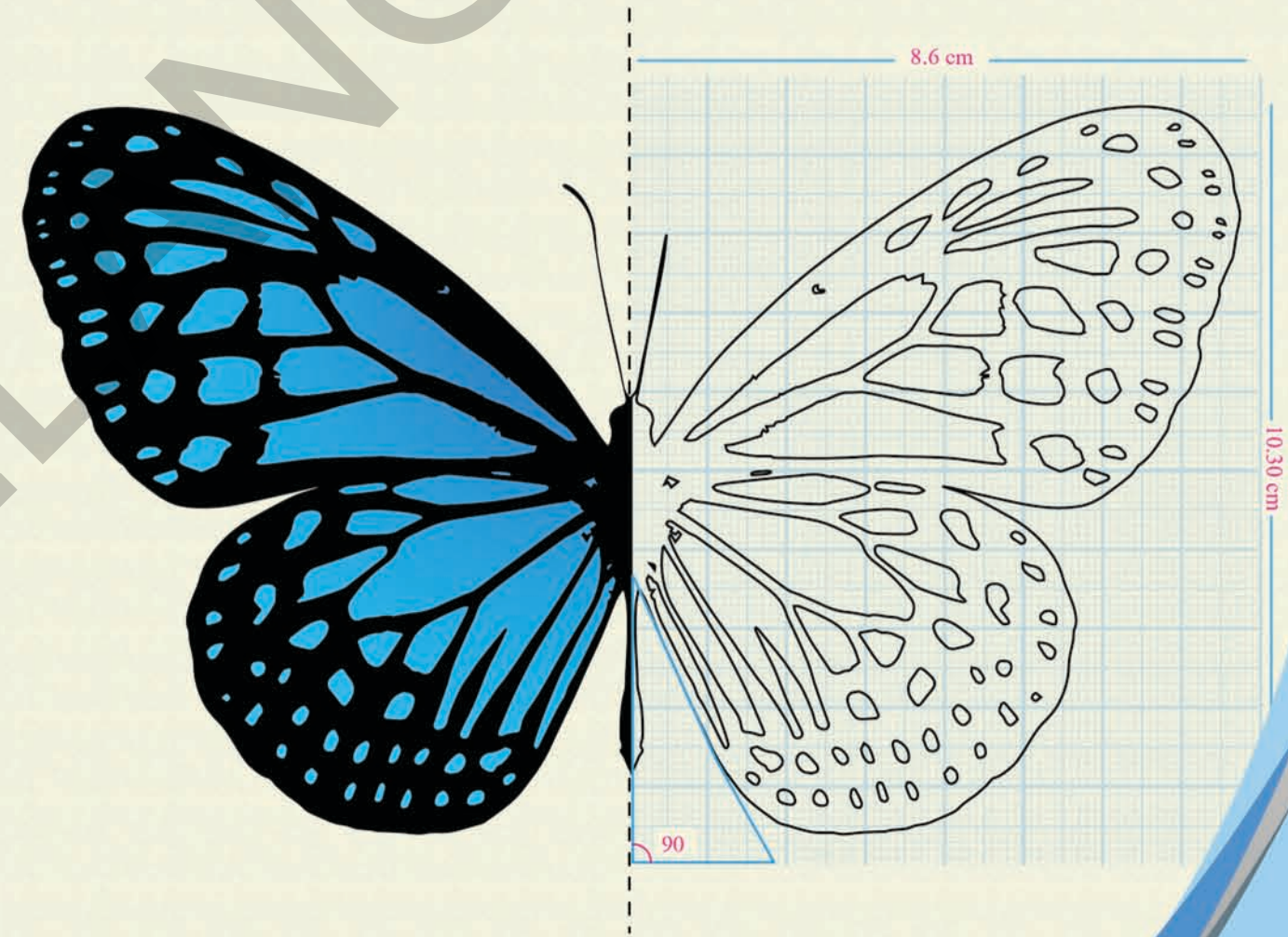


MATHEMATICS

CLASS X

MATHEMATICS

10 CLASS



State Council of Educational Research and Training
Telangana, Hyderabad



Published by
The Government of Telangana
Government's Gift for Students' Progress



MATHEMATICS

Class - X

SCERT, TELANGANA



Published by:
The Government of Telangana, Hyderabad

**Respect the Law
Get the Rights**

**Grow by Education
Behave Humbly**





© Government of Telangana, Hyderabad.

First Published 2014

New Impressions 2015, 2016, 2017, 2018, 2019, 2020, 2021, 2022, 2023, 2024

All rights reserved.

No part of this publication may be reproduced, stored in a retrieval system, or transmitted, in any form or by any means without the prior permission in writing of the publisher, nor be otherwise circulated in any form of binding or cover other than that in which it is published and without a similar condition including this condition being imposed on the subsequent purchaser.

The copy right holder of this book is the Director of School Education, Hyderabad, Telangana.

This Book has been printed on 90 G.S.M. Maplitho
Title Page 250 G.S.M. White Art Card

Government's Gift for Students' Progress 2024-25

Printed in India
at the Telangana Govt. Text Book Press,
Mint Compound, Hyderabad,
Telangana.



Foreword

Education is a process of human enlightenment and empowerment. Recognizing the enormous potential of education, all progressive societies have committed themselves to the Universalization of Elementary Education with a strong determination to provide quality education to all. As a part of its continuation, universalization of Secondary Education has gained momentum.

In the secondary stage, the beginning of the transition from functional mathematics studied upto the primary stage to the study of mathematics as a discipline takes place. The logical proofs of propositions, theorems etc. are introduced at this stage. Apart from being a specific subject, it is connected to other subjects involving analysis and through concomitant methods. It is important that children finish the secondary level with the sense of confidence to use mathematics in organising experience and motivation to continue learning in High level and become good citizens of India.

I am confident that the children in our state Telangana learn to enjoy mathematics, make mathematics a part of their life experience, pose and solve meaningful problems, understand the basic structure of mathematics by reading this text book.

For teachers, to understand and absorb critical issues on curricular and pedagogic perspectives duly focusing on learning in place of marks, is the need of the hour. Also coping with a mixed class room environment is essentially required for effective transaction of curriculum in teaching learning process. Nurturing class room culture to inculcate positive interest among children with difference in opinions and presumptions of life style, to infuse life in to knowledge is a thrust in the teaching job.

The afore said vision of mathematics teaching presented in State Curriculum Frame work (SCF -2011) has been elaborated in its mathematics position paper which also clearly lays down the academic standards of mathematics teaching in the state. The text books make an attempt to concretize all the sentiments.

With an intention to help the students to improve their understanding skills in both the languages i.e. English and Telugu, the Government of Telangana has redesigned this book as bilingual textbook in two parts. Part-1 comprises 1, 2, 3, 4, 8, 11, 12, 14 lessons and Part-2 comprises 5, 6, 7, 9, 10, 13 lessons.

The State Council for Education Research and Training Telangana appreciates the hard work of the text book development committee and several teachers from all over the state who have contributed to the development of this text book. I am thankful to the District Educational Officers, Mandal Educational Officers and head teachers for making this possible. I also thank the institutions and organizations which have given their time in the development of this text book. I am grateful to the office of the Commissioner and Director of School Education for extending co-operation in developing this text book.

Our special thanks to Faculty of School of Education Tata Institute of Social Sciences (TISS), Hyderabad and Sri Ramesh Khade, Communication Officer, CETE, TISS-Mumbai and Designers identified by SCERT for their technical support in redesigning of the textbooks.

Place : Hyderabad

Date : 07 December, 2022

Director

SCERT, Hyderabad



National Anthem

Jana-gana-mana-adhinayaka, jaya he
Bharata-bhagya-vidhata.
Punjab-Sindh-Gujarat-Maratha
Dravida-Utkala-Banga
Vindhya-Himachala-Yamuna-Ganga
Uchchhala-jaladhi-taranga.
Tava shubha name jage,
Tava shubha asisa mage,
Gahe tava jaya gatha,
Jana-gana-mangala-dayaka jaya he
Bharata-bhagya-vidhata.
Jaya he! jaya he! jaya he!
Jaya jaya jaya, jaya he!!

- Rabindranath Tagore

Pledge

“India is my country. All Indians are my brothers and sisters.
I love my country, and I am proud of its rich and varied heritage.
I shall always strive to be worthy of it.
I shall give my parents, teachers and all elders respect,
and treat everyone with courtesy. I shall be kind to animals
To my country and my people, I pledge my devotion.
In their well-being and prosperity alone lies my happiness.”

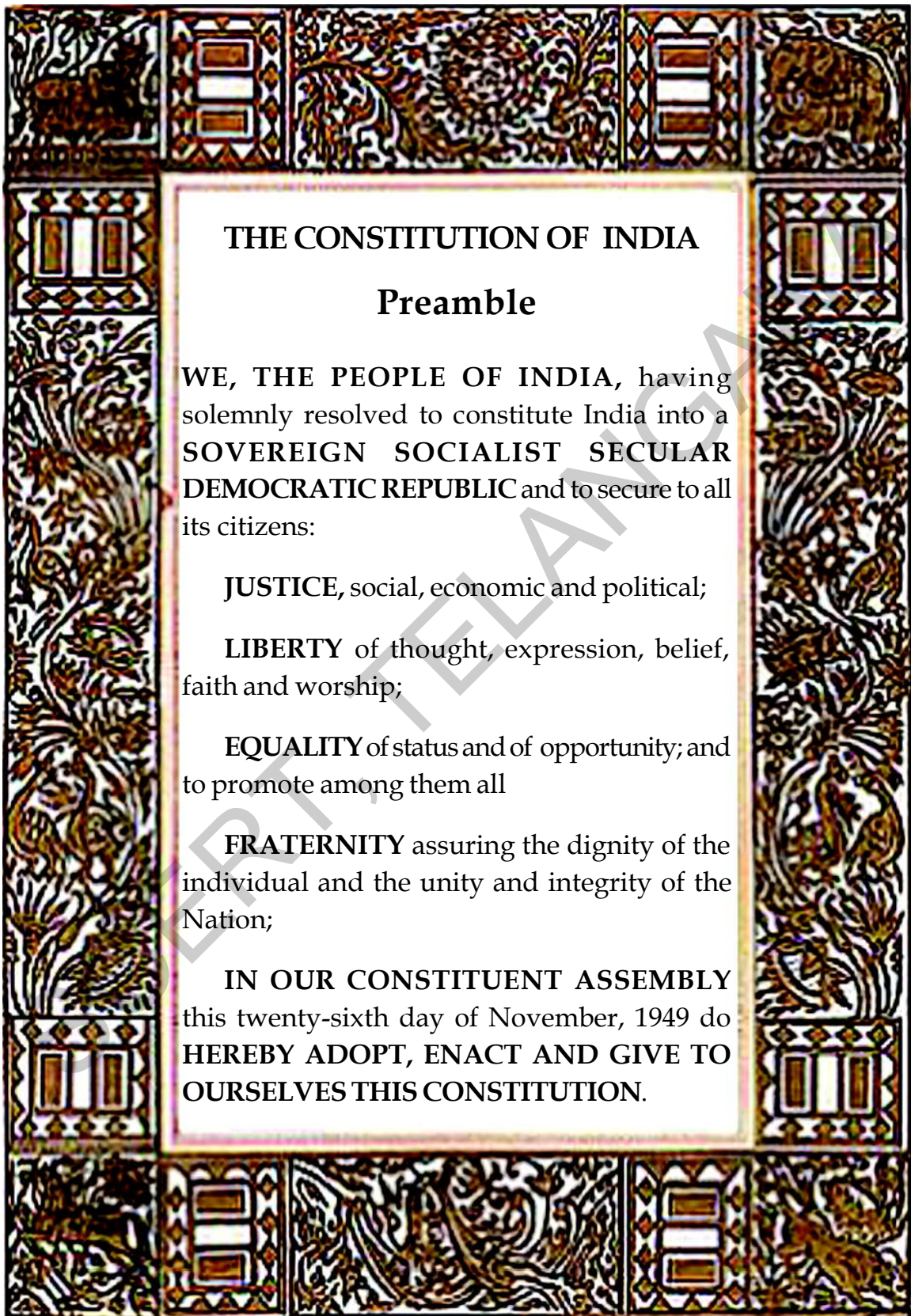
- Pydimarri Venkata Subba Rao



Index

CHAPTER NUMBER	CONTENTS	NO. OF PERIODS	SYLLABUS TO BE COVERED DURING	PAGE NUMBER
01	Real Numbers	15	June	1 - 27
02	Sets	08	June	28 - 50
03	Polynomials	08	July	51 - 76
04	Pair of Linear Equations in Two Variables	15	September	77 - 104
05	Quadratic Equations	12	October	105 - 128
06	Progressions	11	January	129 - 162
07	Coordinate Geometry	12	November	163- 194
08	Similar Triangles	18	July, August	195 - 228
09	Tangents and Secants to a Circle	15	November	229 - 248
10	Mensuration	10	December	249 - 272
11	Trigonometry	15	August	273 - 297
12	Applications of Trigonometry	08	September	298 - 308
13	Probability	10	January	309 - 326
14	Statistics	15	July	327 - 356
Appendix	Mathematical Modelling	08	January	357 - 369
	Answers			370 - 388
	Revision		February	





THE CONSTITUTION OF INDIA

Preamble

WE, THE PEOPLE OF INDIA, having solemnly resolved to constitute India into a **SOVEREIGN SOCIALIST SECULAR DEMOCRATIC REPUBLIC** and to secure to all its citizens:

JUSTICE, social, economic and political;

LIBERTY of thought, expression, belief, faith and worship;

EQUALITY of status and of opportunity; and to promote among them all

FRATERNITY assuring the dignity of the individual and the unity and integrity of the Nation;

IN OUR CONSTITUENT ASSEMBLY this twenty-sixth day of November, 1949 do **HEREBY ADOPT, ENACT AND GIVE TO OURSELVES THIS CONSTITUTION.**





1.1 Introduction

"God made the integers. All else is the work of man"– Leopold Kronecker.

Life is full of numbers. Imagine the moment you were born. Your parents probably noted the time you were born, your weight, your length and the most important thing: counted your fingers and toes. After that, numbers accompany you throughout life.

What are the other contexts where you deal with numbers? We use the numbers to tell our age to keep track of our income and to find the savings after spending certain amount of money. Similarly, we measure our wealth also.

In this chapter, we are going to explore the notion of the numbers. Numbers play a fundamental role within the realm of mathematics. We will come to see the richness of numbers and delve into their surprising traits. Some collection of numbers fit so well together that they actually lead to notions of aesthetics and beauty.

For that, let us look in to a puzzle.

In a garden, a swarm of bees are settling in equal number on same flowers. When they settle on two flowers, one bee will be left out. When they settle on three flowers, two bees will be left out. When they settle on four flowers, three bees will be left out. Similarly, when they settle on five flowers, no bee will be left out. If there are at most fifty bees, how many bees are there in the swarm?

Let us analyse and solve this puzzle.

Let the number of bees be ' x '.

Then working backwards we see that $x \leq 50$.

If the swarm of bees is divided into 5 equal groups no bee will be left, which translates to $x = 5a + 0$ for some natural number ' a '.



If the swarm is divided into 4 equal groups 3 bees will be left out and it translates to $x = 4b + 3$ for some natural number b .

If the swarm is divided into 3 equal groups 2 bees will be left out and it translates to $x = 3c + 2$ for some natural number c .

If the swarm is divided into 2 equal groups 1 bee will be left out and it translates to $x = 2d + 1$ for some natural number d .

That is, in each case we have a positive integer y (in this example y takes values 5, 4, 3 and 2 respectively) which divides x and leaves remainder ' r ' (in our case r is 0, 3, 2 and 1 respectively), that is **smaller than** y . In the process of writing above equations, we have used division algorithm unknowingly.

Getting back to our puzzle. We must look for the multiples of 5 that satisfy all the conditions. Hence $x = 5a + 0$.

If a number leaves remainder 1 when it is divided by 2, we must consider odd multiples only. In this case, we have 5, 15, 25, 35 and 45. Similarly, if we check for the remaining two conditions on these numbers we will get 35 as the only possible number.

Therefore, the swarm of bees contains 35 bees.

Let us verify the answer.

When 35 is divided by 2, the remainder is 1. That can be written as

$$35 = 2 \times 17 + 1$$

When 35 is divided by 3, the remainder is 2. That can be written as

$$35 = 3 \times 11 + 2$$

When 35 is divided by 4, the remainder is 3. That can be written as

$$35 = 4 \times 8 + 3$$

and when 35 is divided by 5, the remainder is '0'. That can be written as

$$35 = 5 \times 7 + 0$$

Let us generalise this. For each pair of positive integers a and b (dividend and divisor respectively), we can find the whole numbers q and r (quotient and remainder respectively) satisfying the relation $a = bq + r$, $0 \leq r < b$





Do This

Find q and r for the following pairs of positive integers a and b , satisfying $a = bq + r$.

(i) $a = 13, b = 3$

(ii) $a = 80, b = 8$

(iii) $a = 125, b = 5$

(iv) $a = 132, b = 11$



Think & Discuss

In questions of above "DO THIS", what is the nature of q and r ?

Theorem-1.1 : (Division Algorithm) : Given positive integers a and b , there exist unique pair of whole numbers q and r satisfying $a = bq + r, 0 \leq r < b$.

This result was first recorded in Book VII of Euclid's Elements. Euclid's algorithm is based on this division algorithm.

Further, Euclid's algorithm is a technique to compute the Highest Common Factor (HCF) of two given integers. Recall that the HCF of two positive integers a and b is the greatest positive integer d that divides both a and b .

For example, let us find the HCF of 60 and 100, through the following activity.



Activity

Take two paper strips of equal width and having lengths 60 cm, and 100 cm. Our task is to find the maximum length of a strip which can measure both the strips completely

Take 60 cm strip and measure the 100 cm strip with it. Cut off the left over 40 cm. Now, take this 40 cm strip and measure the 60 cm strip with it. Cut off the left over 20 cm. Now, take this 20 cm strip and measure the 40 cm with it.

Since nothing is left over, we may conclude that 20 cm strip is the longest strip which can measure both 60 cm and 100 cm strips without leaving any part.



Let us link the process we followed in the "Activity" to Euclid's algorithm to find HCF of 60 and 100.

When 100 is divided by 60, the remainder is 40

$$100 = (60 \times 1) + 40$$

Now consider the division of 60 with the remainder 40 in the above equation and apply the division algorithm.

$$60 = (40 \times 1) + 20$$

Now consider the division of 40 with the remainder 20, and apply the division lemma

$$40 = (20 \times 2) + 0$$

Notice that the remainder has become zero and we cannot proceed any further. We claim that the HCF of 60 and 100 is the divisor at this stage, i.e. 20. (You can easily verify this by listing all the factors of 60 and 100.) We observe that it is a series of well defined steps to find HCF of 60 and 100. So, let us state **Euclid's algorithm** clearly.

To obtain the HCF of two positive integers, say c and d with $c > d$, follow the steps below:

Step 1 : Apply Euclid's Division Lemma, to c and d . So, we find unique pair of whole numbers, q and r such that $c = dq + r$, $0 \leq r < d$.

Step 2 : If $r = 0$, d is the HCF of c and d . If $r \neq 0$, apply the division lemma to d and r .

Step 3 : Continue the process till the remainder is zero. The divisor at this stage will be the required HCF.

This algorithm works because $\text{HCF}(c, d) = \text{HCF}(d, r)$ where the symbol $\text{HCF}(m, n)$ denotes the HCF of any two positive integers m and n .



Do This

Find the HCF of the following by using Euclid algorithm.

- (i) 50 and 70 (ii) 96 and 72 (iii) 300 and 550
(iv) 1860 and 2015





Think & Discuss

Can you find the HCF of 1.2 and 0.12 by using Euclid division algorithm? Justify your answer.

Euclid's algorithm is useful for calculating the HCF of very large numbers, and it was one of the earliest examples of an algorithm that a computer had been programmed to carry out.

Remarks :

1. Euclid's algorithm and division algorithm are so closely interlinked that people often call former as the division algorithm also.
2. Although division algorithm is stated for only positive integers, it can be extended for all integers a and b where $b \neq 0$. However, we shall not discuss this aspect here.

Division algorithm has several applications related to finding properties of numbers. We give some examples of these applications below:

Example 1 : Show that every positive even integer is of the form $2q$, and that every positive odd integer is of the form $2q + 1$, where q is some integer.

Solution : Let a be any positive integer and $b = 2$. Then, by division algorithm, $a = 2q + r$, for some integer $q \geq 0$, and $r = 0$ or $r = 1$, because $0 \leq r < 2$. So, $a = 2q$ or $2q + 1$.

If a is of the form $2q$, then a is an even integer. Also, a positive integer can be either even or odd. Therefore, any positive odd integer is of the form $2q + 1$.

Example 2 : Show that every positive odd integer is of the form $4q + 1$ or $4q + 3$, where q is some integer.

Solution : Let a be a positive odd integer, and $b = 4$. We apply the division algorithm for a and $b = 4$. We get $a = 4q + r$, for $q \geq 0$ and $0 \leq r < 4$. The possible remainders are 0, 1, 2 and 3.

That is, a can be $4q$, $4q + 1$, $4q + 2$, or $4q + 3$, where q is the quotient. However, since a is odd, a cannot be $4q$ which equals $2(2q)$ or $4q + 2$ which equals $2(2q + 1)$ (since they are both divisible by 2). Therefore, any odd integer is of the form $4q + 1$ or $4q + 3$.





Exercise - 1.1

- Use Euclid's algorithm to find the HCF of
(i) 900 and 270 (ii) 196 and 38220 (iii) 1651 and 2032
- Use division algorithm to show that any positive odd integer is of the form $6q + 1$, or $6q + 3$ or $6q + 5$, where q is some integer.
- Use division algorithm to show that the square of any positive integer is of the form $3p$ or $3p + 1$.
- Use division algorithm to show that the cube of any positive integer is of the form $9m$, $9m + 1$ or $9m + 8$.
- Show that one and only one out of n , $n + 2$ or $n + 4$ is divisible by 3, where n is any positive integer.

1.2 The Fundamental theorem of Arithmetic

We know from division algorithm that for given positive integers a and b there exist unique pair of whole numbers q and r satisfying $a = bq + r$, $0 \leq r < b$



Think & Discuss

If $r = 0$, then what is the relationship between a , b and q in $a = bq + r$?

From the above discussion you might have concluded that if $a = bq$, ' a ' is divisible by ' b ' then we can say that ' b ' is a **factor** of ' a '.

For example we know that $24 = 2 \times 12$

$$\begin{aligned} 24 &= 8 \times 3 \\ &= 2 \times 2 \times 2 \times 3 \end{aligned}$$

We know that, if $24 = 2 \times 12$ then we can say that 2 and 12 are factors of 24. We can also write $24 = 2 \times 2 \times 2 \times 3$ and you know that this is the prime factorisation of 24.



Let us take any collection of prime numbers, say 2, 3, 7, 11 and 23. If we multiply some or all of these numbers, allowing them to repeat as many times as we wish, we can produce infinitely many large positive integers. Let us observe a few :

$$2 \times 3 \times 11 = 66$$

$$7 \times 11 = 77$$

$$7 \times 11 \times 23 = 1771$$

$$3 \times 7 \times 11 \times 23 = 5313$$

$$2 \times 3 \times 7 \times 11 \times 23 = 10626$$

$$2^3 \times 3 \times 7^3 = 8232$$

$$2^2 \times 3 \times 7 \times 11 \times 23 = 21252$$

Now, let us suppose collection of all prime numbers. When we take two or more primes from this collection and multiply them, do we get prime number again? or do we get composite number? So, if we multiply all these primes in all possible ways, we will get an infinite collection of composite numbers. Now, let us consider the converse of this statement i.e. if we take a composite number can it be written as a product of prime numbers? The following theorem answers the question.

Theorem-1.2 : (Fundamental Theorem of Arithmetic) : Every composite number can be expressed (factorised) as a product of primes and this factorization is unique, apart from the order in which the prime factors occur.

This gives us the Fundamental Theorem of Arithmetic which says that every composite number can be factorized as a product of primes. To say it more clearly, any given composite number can be factorized as a product of prime numbers in a ‘**unique**’ way, except for the order in which the primes occur. For example, when we factorize 210, we regard $2 \times 3 \times 5 \times 7$ as same as $3 \times 5 \times 7 \times 2$, or any other possible order in which these primes are written. That is, given any composite number there is one and only one way to write it as a product of primes, as long as we are not particular about the order in which the primes occur.

In general, given a composite number x , we factorize it as $x = p_1 \cdot p_2 \cdot p_3 \dots p_n$, where $p_1, p_2, p_3, \dots, p_n$ are primes and written in ascending order, i.e., $p_1 \leq p_2 \leq \dots \leq p_n$. If we express all these equal primes in simplified form, we will get powers of primes. Once we have decided that the order will be ascending, then the way the number is factorised, is unique.

$$\text{For example, } 27300 = 2 \times 2 \times 3 \times 5 \times 5 \times 7 \times 13 = 2^2 \times 3 \times 5^2 \times 7 \times 13$$



Do This

Express 2310 as a product of prime factors. Also see how your friends have factorized the number. Have they done it in the same way? Verify your final product with your friend's result. Try this for 3 or 4 more numbers. What do you conclude?



Let us apply Fundamental Theorem of Arithmetic

Example 3. Consider the numbers of the form 4^n where n is a natural number. Check whether there is any value of n for which 4^n ends with zero?

Solution : If 4^n is to end with zero for a natural number n , it should be divisible by 2 and 5. This means that the prime factorisation of 4^n should contain the prime number 5 and 2. But it is not possible because $4^n = (2)^{2n}$. So 2 is the only prime in the factorisation of 4^n . Since 5 is not present in the prime factorization, there is no natural number n for which 4^n ends with the digit zero.

We have already learnt how to find the HCF (Highest Common Factor) and LCM (Lowest Common Multiple) of two positive integers using the *prime factorization method*. Let us recall this method through the following example.

Example-4. Find the HCF and LCM of 12 and 18 by the prime factorization method.

Solution : We have $12 = 2 \times 2 \times 3 = 2^2 \times 3^1$

$$18 = 2 \times 3 \times 3 = 2^1 \times 3^2$$

Note that $\text{HCF}(12, 18) = 2^1 \times 3^1 = 6 =$ **Product of the smallest power of each common prime factor of the numbers.**

$\text{LCM}(12, 18) = 2^2 \times 3^2 = 36 =$ **Product of the greatest power of each prime factor of the numbers.**

From the example above, you might have noticed that $\text{HCF}(12, 18) \times \text{LCM}[12, 18] = 12 \times 18$. In fact, we can verify that for any two positive integers a and b , $\text{HCF}(a, b) \times \text{LCM}[a, b] = a \times b$. We can use this result to find the LCM of two positive integers, if we have already found the HCF of the two positive integers.



Do This

Find the HCF and LCM of the following given pairs of numbers by prime factorisation method.

- (i) 120, 90 (ii) 50, 60 (iii) 37, 49



Try This

$3^n \times 4^m$ cannot end with the digit 0 or 5 for any natural numbers ' n ' and ' m '. Is it true? Justify your answer.





Exercise - 1.2

- Express each of the following numbers as a product of its prime factors.
(i) 140 (ii) 156 (iii) 3825 (iv) 5005 (v) 7429
- Find the LCM and HCF of the following integers by the prime factorization method.
(i) 12, 15 and 21 (ii) 17, 23, and 29 (iii) 8, 9 and 25
(iv) 72 and 108 (v) 306 and 657
- Check whether 6^n can end with the digit 0 for any natural number n .
- Explain why $7 \times 11 \times 13 + 13$ and $7 \times 6 \times 5 \times 4 \times 3 \times 2 \times 1 + 5$ are composite numbers.
- How will you show that $(17 \times 11 \times 2) + (17 \times 11 \times 5)$ is a composite number? Explain.
- Which digit would occupy the units place of resulting number of 6^{100} .

Now, let us use the Fundamental Theorem of Arithmetic to explore real numbers further. First, we apply this theorem to find out when the decimal form of a rational number is terminating and when it is non-terminating and repeating. Second, we use it to prove the irrationality of numbers such as $\sqrt{2}$, $\sqrt{3}$ and $\sqrt{5}$.

1.2.1 Rational numbers and their decimal expansions

In the previous classes, we have discussed some properties of integers. How can you find the preceding or the succeeding integers for a given integer? You might have recalled that the difference between an integer and its preceding or succeeding integer is 1. You might have found successor or predecessor by adding or subtracting 1 from the given numbers.

In class IX, you learnt that the rational numbers would either be in a terminating decimal form or a non-terminating repeating decimal form. In this section, we are going to consider a rational number, say $\frac{p}{q}$ ($q \neq 0$) and explore exactly when the number $\frac{p}{q}$ is a terminating decimal form and when it is a non-terminating repeating (or recurring) decimal form. We do so by considering certain examples



Let us consider the following terminating decimal numbers.

(i) 0.375 (ii) 1.04 (iii) 0.0875 (iv) 12.5

Now, let us express them in $\frac{p}{q}$ form.

$$(i) \quad 0.375 = \frac{375}{1000} = \frac{375}{10^3} \qquad (ii) \quad 1.04 = \frac{104}{100} = \frac{104}{10^2}$$

$$(iii) \quad 0.0875 = \frac{875}{10000} = \frac{875}{10^4} \qquad (iv) \quad 12.5 = \frac{125}{10} = \frac{125}{10^1}$$

We see that all terminating decimal numbers taken by us can be expressed in $\frac{p}{q}$ form whose denominators are powers of 10. Let us now factorize the numerator and denominator and then express them in the simplest form :

$$\begin{aligned} \text{Now (i)} \quad 0.375 &= \frac{375}{10^3} = \frac{3 \times 5^3}{2^3 \times 5^3} = \frac{3}{2^3} = \frac{3}{8} \\ \text{(ii)} \quad 1.04 &= \frac{104}{10^2} = \frac{2^3 \times 13}{2^2 \times 5^2} = \frac{26}{5^2} = \frac{26}{25} \\ \text{(iii)} \quad 0.0875 &= \frac{875}{10^4} = \frac{5^3 \times 7}{2^4 \times 5^4} = \frac{7}{2^4 \times 5} = \frac{7}{80} \\ \text{(iv)} \quad 12.5 &= \frac{125}{10} = \frac{5^3}{2 \times 5} = \frac{25}{2} \end{aligned}$$

Have you observed any pattern in the denominators of the above numbers? It appears that when the decimal number is expressed in its simplest rational form, (p and q are coprimes) and the denominator (i.e., q) has only powers of 2, or powers of 5, or both. This is because 2 and 5 are the only prime factors of powers of 10.

From the above examples, you have seen that any rational number that terminates in its decimal form can be expressed in a rational form whose denominator is a power of 2 or 5 or both. So, when we write such a rational number in $\frac{p}{q}$ form, the prime factorization of q will be in $2^n 5^m$, where n, m are some non-negative integers.

We can state our result formally as below:



Theorem-1.3 : Let x be a rational number whose decimal form terminates. Then x can be expressed in the form of $\frac{p}{q}$, where p and q are coprimes, and the prime factorization of q is of the form $2^n 5^m$, where n, m are non-negative integers.



Do This

Write the following terminating decimals in the form of $\frac{p}{q}$, $q \neq 0$ and p, q are co-primes

- (i) 15.265 (ii) 0.1255 (iii) 0.4 (iv) 23.34 (v) 1215.8

And also write the denominators in $2^n 5^m$ form.

Now, if we have a rational number in the form of $\frac{p}{q}$ and the prime factorization of q is of the form $2^n 5^m$, where n, m are non-negative integers, then does $\frac{p}{q}$ have a terminating decimal expansion?

So, it seems to make sense to convert a rational number of the form $\frac{p}{q}$, where q is of the form $2^n 5^m$, to an equivalent rational number of the form $\frac{a}{b}$, where b is a power of 10.

Let us go back to our examples above and work backwards.

$$(i) \quad \frac{3}{8} = \frac{3}{2^3} = \frac{3 \times 5^3}{2^3 \times 5^3} = \frac{375}{10^3} = 0.375 \qquad (ii) \quad \frac{26}{25} = \frac{26}{5^2} = \frac{13 \times 2^3}{2^2 \times 5^2} = \frac{104}{10^2} = 1.04$$

$$(iii) \quad \frac{7}{80} = \frac{7}{2^4 \times 5} = \frac{7 \times 5^3}{2^4 \times 5^4} = \frac{875}{10^4} = 0.0875 \qquad (iv) \quad \frac{25}{2} = \frac{5^3}{2 \times 5} = \frac{125}{10} = 12.5$$

So, these examples show us how we can convert a rational number of the form $\frac{p}{q}$, where q is of the form $2^n 5^m$, to an equivalent rational number of the form $\frac{a}{b}$, where b is a power of 10. Therefore, the decimal forms of such a rational number terminate. We find that a rational number of the form $\frac{p}{q}$, where q is a power of 10, is a terminating decimal number.

So, we conclude that the converse of Theorem 1.3 is also true which can be formally stated as :



Theorem 1.4 : Let $x = \frac{p}{q}$ be a rational number, such that the prime factorization of q is of the form $2^n 5^m$, where n and m are non-negative integers. Then x has a decimal expansion which terminates.



Do This

Write the denominator of the following rational numbers in $2^n 5^m$ form where n and m are non-negative integers and then write them in their decimal form

(i) $\frac{3}{4}$

(ii) $\frac{7}{25}$

(iii) $\frac{51}{64}$

(iv) $\frac{14}{25}$

(v) $\frac{80}{100}$

1.2.2 Non-terminating, recurring decimals in rational numbers

Let us now consider rational numbers whose decimal expansions are non-terminating and recurring.

For example, let us look at the decimal form of $\frac{1}{7}$.

$\frac{1}{7} = 0.1428571428571 \dots$ which is a non-terminating and recurring

decimal number. Notice that the block of digits '142857' is repeating in the quotient.

Notice that the denominator i.e., 7 can't be written in the form $2^n 5^m$.

$$\begin{array}{r} 0.1428571 \\ 7 \overline{) 1.0000000} \\ \underline{7} \\ 30 \\ \underline{28} \\ 20 \\ \underline{14} \\ 60 \\ \underline{56} \\ 40 \\ \underline{35} \\ 50 \\ \underline{49} \\ 10 \\ \underline{7} \\ 30 \end{array}$$



Do This

Write the following rational numbers in the decimal form and find out the block of repeating digits in the quotient.

(i) $\frac{1}{3}$

(ii) $\frac{2}{7}$

(iii) $\frac{5}{11}$

(iv) $\frac{10}{13}$

From the 'Do this' exercise and from the example taken above, we can formally state as below:

Theorem-1.5 : Let $x = \frac{p}{q}$ be a rational number, such that the prime factorization of q is not of the form $2^n 5^m$, where n and m are non-negative integers. Then, x has a decimal expansion which is non-terminating repeating (recurring).



From the above discussion, we can conclude that the decimal form of every rational number is either terminating or non-terminating repeating.

Example-5. Using the above theorems, without actual division, state whether decimal form of the following rational numbers are terminating or non-terminating, repeating decimals.

$$(i) \frac{16}{125} \quad (ii) \frac{25}{32} \quad (iii) \frac{100}{81} \quad (iv) \frac{41}{75}$$

Solution : (i) $\frac{16}{125} = \frac{16}{5 \times 5 \times 5} = \frac{16}{5^3}$ (a terminating decimal form.)

(ii) $\frac{25}{32} = \frac{25}{2 \times 2 \times 2 \times 2 \times 2} = \frac{25}{2^5}$ (a terminating decimal form.)

(iii) $\frac{100}{81} = \frac{100}{3 \times 3 \times 3 \times 3} = \frac{100}{3^4}$ (a non-terminating repeating decimal form.)

(iv) $\frac{41}{75} = \frac{41}{3 \times 5 \times 5} = \frac{41}{3 \times 5^2}$ (a non-terminating repeating decimal form.)

Example-6. Write the decimal form of the following rational numbers without actual division.

$$(i) \frac{35}{50} \quad (ii) \frac{21}{25} \quad (iii) \frac{7}{8}$$

Solution : (i) $\frac{35}{50} = \frac{7 \times 5}{2 \times 5 \times 5} = \frac{7}{2 \times 5} = \frac{7}{10^1} = 0.7$

(ii) $\frac{21}{25} = \frac{21}{5 \times 5} = \frac{21 \times 2^2}{5 \times 5 \times 2^2} = \frac{21 \times 4}{5^2 \times 2^2} = \frac{84}{10^2} = 0.84$

(iii) $\frac{7}{8} = \frac{7}{2 \times 2 \times 2} = \frac{7}{2^3} = \frac{7 \times 5^3}{(2^3 \times 5^3)} = \frac{7 \times 125}{(2 \times 5)^3} = \frac{875}{(10)^3} = 0.875$



Exercise - 1.3

1. Write the following rational numbers in their decimal form and also state which are terminating and which are non-terminating repeating decimal form.

$$(i) \frac{3}{8} \quad (ii) \frac{229}{400} \quad (iii) 4\frac{1}{5} \quad (iv) \frac{2}{11} \quad (v) \frac{8}{125}$$

2. Without performing division, state whether the following rational numbers will have a terminating decimal form or a non-terminating repeating decimal form.

$$(i) \frac{13}{3125} \quad (ii) \frac{11}{12} \quad (iii) \frac{64}{455} \quad (iv) \frac{15}{1600} \quad (v) \frac{29}{343}$$

$$(vi) \frac{23}{2^3 \cdot 5^2} \quad (vii) \frac{129}{2^2 \cdot 5^7 \cdot 7^5} \quad (viii) \frac{9}{15} \quad (ix) \frac{36}{100} \quad (x) \frac{77}{210}$$



3. Write the following rational numbers in decimal form using Theorem 1.4.

(i) $\frac{13}{25}$ (ii) $\frac{15}{16}$ (iii) $\frac{23}{2^3 \cdot 5^2}$ (iv) $\frac{7218}{3^2 \cdot 5^2}$ (v) $\frac{143}{110}$

4. Express the following decimal numbers in the form of $\frac{p}{q}$ and write the prime factors of q . What do you observe?

(i) 43.123 (ii) 0.120112001120001... (iii) $43.\overline{12}$ (iv) $0.\overline{63}$

1.3 Irrational numbers

In class IX, you were introduced irrational numbers and some of their properties. You studied about their existence and how the rationals and the irrationals together made up the real numbers. You even studied how to locate irrationals on the number line. However, we did not prove that they were irrationals. In this section, we will prove that $\sqrt{2}$, $\sqrt{3}$, $\sqrt{5}$ and \sqrt{p} in general is irrational, where p is a prime. One of the theorems, we use in our proof, is the fundamental theorem of Arithmetic.

Recall, a real number is called *irrational* (Q') if it cannot be written in the form $\frac{p}{q}$, where p and q are integers and $q \neq 0$. Some examples of irrational numbers, with which you are already familiar, are :

$$\sqrt{2}, \sqrt{3}, \sqrt{15}, \pi, 0.10110111011110\dots, \text{etc.}$$

Before we prove that $\sqrt{2}$ is irrational, we will look at a theorem, the proof of which is based on the Fundamental Theorem of Arithmetic.

Theorem-1.6 : Let p be a prime number. If p divides a^2 , (where a is a positive integer), then p divides a .

Proof : Let the prime factorization of a be as follows :

$$a = p_1 p_2 \dots p_n, \text{ where } p_1, p_2, \dots, p_n \text{ are primes, not necessarily distinct.}$$

$$\text{Therefore } a^2 = (p_1 p_2 \dots p_n) (p_1 p_2 \dots p_n) = p_1^2 p_2^2 \dots p_n^2.$$

We are given that p divides a^2 . Therefore, from the Fundamental Theorem of Arithmetic, it follows that p is one of the prime factors of a^2 . However, using the uniqueness part of the Fundamental Theorem of Arithmetic, we realise that the only prime factors of a^2 are p_1, p_2, \dots, p_n . So p is one of p_1, p_2, \dots, p_n .

Now, since $a = p_1 p_2 \dots p_n$, p divides a . Hence the result.





Do This

Verify the theorem proved above for $p=2, p=3, p=5$ and $p=7$ for $a^2=1, 4, 9, 25, 36, 49, 64$ and 81 .

Now, we prove that $\sqrt{2}$ is irrational. We will use a method called proof by contradiction.

Example 7. Show that $\sqrt{2}$ is irrational.

Proof : Let us assume that $\sqrt{2}$ is rational, as we are using proof by contradiction.

If it is rational, then there must exist two integers r and s ($s \neq 0$) such that $\sqrt{2} = \frac{r}{s}$.

If r and s have a common factor other than 1, then, we divide r and s by their highest common factor to get $\sqrt{2} = \frac{a}{b}$, where a and b are co-prime. So, $b\sqrt{2} = a$.

On squaring both sides and rearranging, we get $2b^2 = a^2$. Therefore, 2 divides a^2 .

Now, by Theorem 1.6, it follows that since 2 is dividing a^2 , it also divides a .

So, we can write $a = 2c$ for some integer c . On squaring, we get $a^2 = (2c)^2$

Substituting for a^2 , we get $2b^2 = (2c)^2$ so that $2b^2 = 4c^2$, that is, $b^2 = 2c^2$.

This means that 2 divides b^2 , so 2 divides b also (again using Theorem 1.6 with $p=2$).

Therefore, both a and b have 2 as a common factor.

But this contradicts the fact that a and b are co-prime. (No other factor except 1) This contradiction has arisen because of our assumption that $\sqrt{2}$ is rational. Thus our assumption is false. So, we conclude that $\sqrt{2}$ is irrational.

In general, it can be shown that \sqrt{d} is irrational whenever d is a positive integer which is not the square of another integer. As such, it follows that $\sqrt{6}, \sqrt{8}, \sqrt{15}, \sqrt{24}$ etc. are all irrational numbers.

In class IX, we mentioned that :

- the sum or difference of a rational and an irrational number is irrational
- the product or quotient of a non-zero rational and an irrational number is irrational.

We prove some of these in particular cases here.



Example-8. Show that $5 - \sqrt{3}$ is irrational.

Solution : Let us assume that $5 - \sqrt{3}$ is rational, (proof by contradiction)

That is, we can find coprimes a and b ($b \neq 0$) such that $5 - \sqrt{3} = \frac{a}{b}$.

Therefore, $5 - \frac{a}{b} = \sqrt{3}$

we get $\sqrt{3} = 5 - \frac{a}{b}$

Since a and b are integers ($b \neq 0$), $5 - \frac{a}{b}$ is rational and $\sqrt{3}$ is also rational.

But this contradicts the fact that $\sqrt{3}$ is irrational number.

This contradiction has arisen because of our assumption that $5 - \sqrt{3}$ is rational.

So, we conclude that $5 - \sqrt{3}$ is irrational.

Example-9. Show that $3\sqrt{2}$ is irrational.

Solution : Let us assume, the contrary that $3\sqrt{2}$ is rational.

i.e., we can find co-primes a and b ($b \neq 0$) such that $3\sqrt{2} = \frac{a}{b}$.

we get $\sqrt{2} = \frac{a}{3b}$.

Since $3, a$ and b are integers, $\frac{a}{3b}$ is rational and so $\sqrt{2}$ is rational.

But this contradicts the fact that $\sqrt{2}$ is irrational.

So, we conclude that $3\sqrt{2}$ is irrational.

Example-10. Prove that $\sqrt{2} + \sqrt{3}$ is irrational.

Solution : Let us suppose that $\sqrt{2} + \sqrt{3}$ is rational.

Let $\sqrt{2} + \sqrt{3} = \frac{a}{b}$, where a, b are integers and $b \neq 0$

Therefore, $\sqrt{2} = \frac{a}{b} - \sqrt{3}$.



Squaring on both sides, we get

$$2 = \frac{a^2}{b^2} + 3 - 2\frac{a}{b}\sqrt{3}$$

Rearranging

$$\frac{2a}{b}\sqrt{3} = \frac{a^2}{b^2} + 3 - 2$$

$$= \frac{a^2}{b^2} + 1$$

$$\sqrt{3} = \frac{a^2 + b^2}{2ab}$$

Since a, b are integers, $\frac{a^2 + b^2}{2ab}$ is rational and so $\sqrt{3}$ is rational.

This contradicts the fact that $\sqrt{3}$ is irrational. Hence $\sqrt{2} + \sqrt{3}$ is irrational.

Note :

1. The sum of two irrational numbers need not be irrational.

For example, if $a = \sqrt{2}$ and $b = -\sqrt{2}$, then both a and b are irrational, but $a + b = 0$ which is rational.

2. The product of two irrational numbers need not be irrational.

For example, $a = \sqrt{2}$ and $b = 3\sqrt{2}$, where both a and b are irrational, but $ab = 6$ which is rational.



Exercise - 1.4

1. Prove that the following are irrational.

(i) $\frac{1}{\sqrt{2}}$ (ii) $\sqrt{3} + \sqrt{5}$ (iii) $6 + \sqrt{2}$ (iv) $\sqrt{5}$ (v) $3 + 2\sqrt{5}$

2. Prove that $\sqrt{p} + \sqrt{q}$ is an irrational, where p, q are primes.

1.4 Exponentials Revision

We know the power ' a^n ' of a number ' a ' with natural exponent ' n ' is the product of ' n ' factors each of which is equal to ' a ' i.e $a^n = \underbrace{a \cdot a \cdot a \cdots a}_{n\text{-factors}}$

$2^0, 2^1, 2^2, 2^3$ are powers of 2

$3^0, 3^1, 3^2, 3^3$ are powers of 3



We also know that when 81 is written as 3^4 , it is said to be in exponential form. The number '4' is the 'exponent' or 'index' and 3 is the 'base'. We read it as "81 is the 4th power of base 3".

Once, recall the laws of exponents

If a, b are real numbers, where $a \neq 0, b \neq 0$ and m, n are integers, then

$$(i) a^m \cdot a^n = a^{m+n}; \quad (ii) \frac{a^m}{a^n} = a^{m-n} \quad (iii) (ab)^m = a^m \cdot b^m \quad (iv) \left(\frac{a}{b}\right)^m = \frac{a^m}{b^m}$$

$$(v) (a^m)^n = a^{m \cdot n} \quad (vi) a^0 = 1 \quad (vii) a^{-m} = \frac{1}{a^m}$$



Do This

1. Evaluate

$$(i) 2^1 \quad (ii) (4.73)^0 \quad (iii) 0^3 \quad (iv) (-1)^4 \quad (v) (0.25)^{-1} \quad (vi) \left(\frac{5}{4}\right)^2 \quad (vii) \left(1\frac{1}{4}\right)^2$$

2. (a) Express 10, 100, 1000, 10000, 100000 in exponential form

(b) Express the following products in simplest exponential form

$$(i) 16 \times 64 \quad (ii) 25 \times 125 \quad (iii) 128 \div 32$$

1.4.1 Exponentials and Logarithms

Let us Observe the following

$$2^x = 4 = 2^2 \text{ gives } x = 2$$

$$3^y = 81 = 3^4 \text{ gives } y = 4$$

$$10^z = 100000 = 10^5 \text{ gives } z = 5$$

Can we find the values of x for the following?

$$2^x = 5, \quad 3^x = 7, \quad 10^x = 5$$

If so, what are the values of x ?

For $2^x = 5$, What should be the power to which 2 must be raised to get 5?

Therefore we need to establish new relationship between x and 5.

For this, we have introduced the relation of logarithms.

Consider $y = 2^x$, we need that value of x for which y becomes 5 from the facts that if $x = 1$ then $y = 2^1 = 2$, if $x = 2$ then $y = 2^2 = 4$, if $x = 3$ then $y = 2^3 = 8$, we observe that x lies between 2 and 3.

We will now use the graph of $y = 2^x$ to locate such a ' x ' for which $2^x = 5$.



Graph of exponential 2^x

Let us draw the graph of $y = 2^x$

For this we compute the value of 'y' by choosing some values for 'x'.

Show this value of x and y are in the following table form:

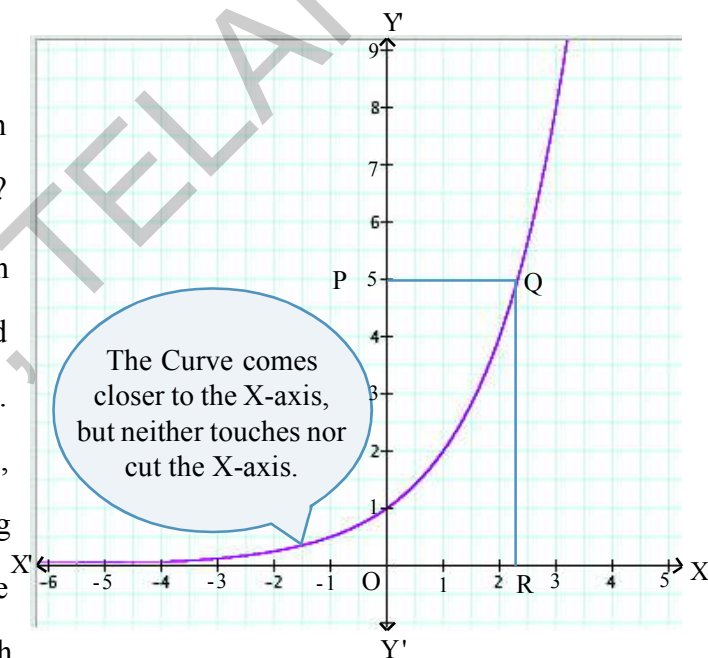
x	-3	-2	-1	0	1	2	3
$y=2^x$	$\frac{1}{8}$	$\frac{1}{4}$	$\frac{1}{2}$	1	2	4	8

We plot the points and connect them in a smooth curve.

Note that as x increases, the value of $y = 2^x$ increases. As 'x' decreases the value of $y = 2^x$ decreases very close to 0, but never attains the value 0.

Let us think, if $y = 2^x$ then for which value of x , y becomes 5?

We know that, in the graph Y-axis represents the value of 2^x and X-axis represents the value of x . Locate the value of 5 on Y-axis, and represent it as a corresponding point "P" on Y-axis. Draw a line parallel to X-axis through P, which meets the graph at the point Q.



Now draw QR perpendicular to X-axis. Can we find the length of OR approximately from the graph? or where does it lie? Thus, we know that the x coordinate of the point R is the required value of x , for which $2^x=5$.

This value of x is called the **logarithm** of 5 to the base 2, written as $\log_2 5$.



It has been difficult to find x when $2^x = 5$ or $3^x = 7$ or $10^x = 5$. Then we have following solutions to the above equations.

If $2^x = 5$ then x is "logarithm of 5 to the base 2" and it is written as $\log_2 5$

If $3^x = 7$ then x is "logarithm of 7 to the base 3" and it is written as $\log_3 7$

If $10^x = 5$ then x is "logarithm of 5 to the base 10" and it is written as $\log_{10} 5$

In general, a and N are positive real numbers such that $a \neq 1$ we define $\log_a N = x \Leftrightarrow a^x = N$.

Let us compare the following two values.

x	-2	-1	0	1	2	3	y	$\frac{1}{4}$	$\frac{1}{2}$	1	2	4	8
$y = 2^x$	$\frac{1}{4}$	$\frac{1}{2}$	1	2	4	8	$x = \log_2 y$	-2	-1	0	1	2	3

Observe the graph $y = 2^x$ in the light of our definition of logarithm

If	$y = \frac{1}{4}$;	$x = -2$	i.e.	$2^{-2} = \frac{1}{4}$	and	$-2 = \log_2 \frac{1}{4}$
	$y = \frac{1}{2}$;	$x = -1$	i.e.	$2^{-1} = \frac{1}{2}$	and	$-1 = \log_2 \frac{1}{2}$
	$y = 2$;	$x = 1$	i.e.	$2^1 = 2$	and	$1 = \log_2 2$
	$y = 4$;	$x = 2$	i.e.	$2^2 = 4$	and	$2 = \log_2 4$
	$y = 8$;	$x = 3$	i.e.	$2^3 = 8$	and	$3 = \log_2 8$

Let us consider one more example :

If $10^y = 25$ then it can be represented as $y = \log_{10} 25$ or $y = \log 25$,

Logarithms of a number to the base 10 are also called common logarithms. In this case, we generally omit the base i.e. $\log_{10} 25$ is also written as $\log 25$.





Do This

(1) Write the following in logarithmic form.

(i) $7 = 2^x$ (ii) $10 = 5^b$ (iii) $\frac{1}{81} = 3^c$ (iv) $100 = 10^z$ (v) $\frac{1}{257} = 4^a$

(2) Write the following in exponential form.

(i) $\log_{10} 100 = 2$ (ii) $\log_5 25 = 2$ (iii) $\log_2 2 = 1$ (iv) $x = \log_2 9$



Try This

Solve the following

(i) $\log_2 32 = x$ (ii) $\log_5 625 = y$ (iii) $\log_{10} 10000 = z$

Can we say "exponential form and logarithmic form" are inverses of one another?

Also, observe that every positive real number has a unique logarithmic value because any horizontal line intersects the graph at only one point.



Think & Discuss

(1) Does $\log_2 0$ exist? Give reasons.

(2) prove (i) $\log_b b = 1$ (ii) $\log_b 1 = 0$ (iii) $\log_b b^x = x$

(iv) if $\log_x 16 = 2$ then $x^2 = 16 \Rightarrow x = \pm 4$, Is it correct or not?

Properties of Logarithms

Logarithms are important in many applications and also in advanced mathematics. We will now establish some basic properties useful in manipulating expressions involving logarithms.

(i) The Product Rule

The properties of exponents correspond to properties of logarithms. For example when we multiply with the same base, we add exponents

i.e. $a^x \cdot a^y = a^{x+y}$



This property of exponents coupled with an awareness that a logarithm is an exponent suggest the **Product Rule**.

Theorem: (Product Rule) Let a, x and y be positive real numbers with $a \neq 1$.

Then $\log_a xy = \log_a x + \log_a y$

i.e., The logarithm of a product is the sum of the logarithms

Proof: Let $\log_a x = m$ and $\log_a y = n$

then we have $a^m = x$ and $a^n = y$

Now $xy = a^m a^n = a^{m+n}$ (Exponential form)

$\therefore \log_a xy = m + n = \log_a x + \log_a y$ (Logarithmic form)



Try This

We know that $\log_{10} 100000 = 5$

Show that you get the same answer by writing $100000 = 1000 \times 100$ and then using the product rule. Verify the answer.



Do This

Express the logarithms of the following as the sum of the logarithm

(i) 35×46 (ii) 235×437 (iii) 2437×3568

(ii) The Quotient Rule

When we divide with the same base, we subtract exponents

$$\text{i.e. } \frac{a^x}{a^y} = a^{x-y}$$

This property is called the **quotient rule**.

Theorem: (Quotient Rule) Let a, x and y be positive real numbers where $a \neq 1$.

Then $\log_a \left(\frac{x}{y}\right) = \log_a x - \log_a y$

Proof: Let $\log_a x = m$ and $\log_a y = n$ then we have $a^m = x$ and $a^n = y$

Now

$$\frac{x}{y} = \frac{a^m}{a^n} = a^{m-n}$$

$$\therefore \log_a \left(\frac{x}{y}\right) = m - n = \log_a x - \log_a y$$

$$\log_a \left(\frac{x}{y}\right) = \log_a x - \log_a y$$

Logarithm of Quotient of two numbers is equal to the difference of two numbers logarithm.





Do This

Express the logarithms of the following as the difference of logarithms

(i) $\frac{23}{34}$

(ii) $\frac{373}{275}$

(iii) $4325 \div 3734$

(iv) $5055 \div 3303$



Think & Discuss

We know that $(a^m)^n = a^{mn}$

Let $a^m = x$ then $m = \log_a x$

$x^n = a^{mn}$ then $\log_a x^n = mn$

$$= n \log_a x \text{ (why?)}$$

(iii) The Power Rule

When an exponential expression is raised to a power, we multiply the exponents

i.e. $(a^m)^n = a^{m \cdot n}$

This property is called the **power rule**.

Theorem: (Power Rule) Let a and x be positive real numbers with $a \neq 0$ and n be any real number

then, $\log_a x^n = n \log_a x$



Try This

We have $\log_2 32 = 5$. Show that we get the same result by writing $32 = 2^5$ and then using power rules. Verify the answer.

Can we find the value of x such that $2^x = 3^5$? In such cases we find the value of $3^5 = 243$. Then we can evaluate the value of x , for which the value of 2^x equals to 243.

Applying the logarithm and using the formula $\log_a x^n = n \log_a x$, easily we can find the values of 3^{25} , 3^{33} etc.

$$2^x = 3^5$$

Taking logarithms to the base 2 on both sides, we get.

$$\log_2 2^x = \log_2 3^5$$

$$x \log_2 2 = 5 \log_2 3$$

$$x = 5 \log_2 3 \quad \left(\because \log_a x^n = n \log_a x \text{ and } \log_a a = 1 \right)$$

We observe that the value of x is the product of 5 and the value of $\log_2 3$.





Do This

Using $\log_a x^n = n \log_a x$, expand the following

- (i) $\log_2 7^{25}$ (ii) $\log_5 8^{50}$ (iii) $\log 5^{23}$ (iv) $\log 1024$

Note: $\log x = \log_{10} x$



Try This

Find the values of the following:

- (i) $\log_2 32$ (ii) $\log_c \sqrt{c}$ (iii) $\log_{10} 0.001$ (iv) $\log_{\frac{2}{3}} \frac{8}{27}$



Think & Discuss

We know that, if $7 = 2^x$ then $x = \log_2 7$. Then, what is the value of $2^{\log_2 7}$? Justify your answer. Generalise the above by taking some more examples for $a^{\log_a N}$

Example-11. Expand $\log \frac{343}{125}$

Solution : As you know, $\log_a \frac{x}{y} = \log_a x - \log_a y$

$$\begin{aligned} \text{So, } \log \frac{343}{125} &= \log 343 - \log 125 \\ &= \log 7^3 - \log 5^3 \\ &= 3\log 7 - 3\log 5 \quad (\text{Since, } \log_a x^n = n \log_a x) \end{aligned}$$

$$\therefore \log \frac{343}{125} = 3(\log 7 - \log 5).$$

Example-12. Write $2\log 3 + 3\log 5 - 5\log 2$ as a single logarithm.

$$\begin{aligned} \text{Solution : } & 2\log 3 + 3\log 5 - 5\log 2 \\ &= \log 3^2 + \log 5^3 - \log 2^5 \quad (\text{Since in } n \log_a x = \log_a x^n) \\ &= \log 9 + \log 125 - \log 32 \\ &= \log (9 \times 125) - \log 32 \quad (\text{Since } \log_a x + \log_a y = \log_a xy) \\ &= \log 1125 - \log 32 \\ &= \log \frac{1125}{32} \quad (\text{Since } \log_a x - \log_a y = \log_a \frac{x}{y}) \end{aligned}$$

$$\therefore 2\log 3 + 3\log 5 - 5\log 2 = \log \frac{1125}{32}$$



Example-13. Solve the equation $3^x = 5^{x-2}$.

Solution : $3^x = 5^{x-2}$

By taking log both sides

$$\log 3^x = \log 5^{x-2}$$

$$x \log_{10} 3 = (x - 2) \log_{10} 5$$

$$x \log_{10} 3 = x \log_{10} 5 - 2 \log_{10} 5$$

$$x \log_{10} 5 - 2 \log_{10} 5 = x \log_{10} 3$$

$$x \log_{10} 5 - x \log_{10} 3 = 2 \log_{10} 5$$

$$x(\log_{10} 5 - \log_{10} 3) = 2 \log_{10} 5$$

$$\therefore x = \frac{2 \log_{10} 5}{\log_{10} 5 - \log_{10} 3}$$

Example-14. Find x if $2 \log 5 + \frac{1}{2} \log 9 - \log 3 = \log x$

Solution : $\log x = 2 \log 5 + \frac{1}{2} \log 9 - \log 3$

$$= \log 5^2 + \log 9^{\frac{1}{2}} - \log 3$$

$$= \log 25 + \log \sqrt{9} - \log 3$$

$$= \log 25 + \log 3 - \log 3$$

$$\log x = \log 25$$

$$\therefore x = 25$$



Exercise - 1.5

1. Determine the value of the following.

(i) $\log_{25} 5$ (ii) $\log_{81} 3$ (iii) $\log_2 \left(\frac{1}{16} \right)$

(iv) $\log_7 1$ (v) $\log_x \sqrt{x}$ (vi) $\log_2 512$

(vii) $\log_{10} 0.01$ (viii) $\log_{\frac{2}{3}} \left(\frac{8}{27} \right)$ (ix) $2^{2+\log_2 3}$

2. Write the following expressions as $\log N$ and find their values.

(i) $\log 2 + \log 5$ (ii) $\log_2 16 - \log_2 2$ (iii) $3 \log_{64} 4$

(iv) $2 \log 3 - 3 \log 2$ (v) $\log 10 + 2 \log 3 - \log 2$



3. Evaluate each of the following in terms of x and y , if it is given that $x = \log_2 3$ and $y = \log_2 5$

- (i) $\log_2 15$ (ii) $\log_2 7.5$ (iii) $\log_2 60$ (iv) $\log_2 6750$

4. Expand the following.

- (i) $\log 1000$ (ii) $\log \left(\frac{128}{625} \right)$ (iii) $\log x^2 y^3 z^4$ (iv) $\log \left(\frac{p^2 q^3}{r^4} \right)$ (v) $\log \sqrt{\frac{x^3}{y^2}}$

5. If $x^2 + y^2 = 25xy$, then prove that $2 \log(x + y) = 3 \log 3 + \log x + \log y$.

6. If $\log \left(\frac{x+y}{3} \right) = \frac{1}{2}(\log x + \log y)$, then find the value of $\frac{x}{y} + \frac{y}{x}$.

7. If $(2.3)^x = (0.23)^y = 1000$, then find the value of $\frac{1}{x} - \frac{1}{y}$.

8. If $2^{x+1} = 3^{1-x}$ then find the value of x .

9. Is (i) $\log 2$ rational or irrational? Justify your answer.

(ii) $\log 100$ rational or irrational? Justify your answer.



Optional Exercise

[For extensive learning]

1. Can the number 6^n , n being a natural number, end with the digit 5? Give reason.
2. Is $7 \times 5 \times 3 \times 2 + 3$ a composite number? Justify your answer.
3. Prove that $(2\sqrt{3} + \sqrt{5})$ is an irrational number. Also check whether $(2\sqrt{3} + \sqrt{5})(2\sqrt{3} - \sqrt{5})$ is rational or irrational.
4. If $x^2 + y^2 = 6xy$, prove that $2 \log(x + y) = \log x + \log y + 3 \log 2$
5. Find the number of digits in 4^{013} , if $\log_{10} 2 = 0.3010$.

Note : Ask your teacher about integral part and decimal part of the logarithm of a number.

Suggested Projects

Euclid Algorithm

- Find the H.C.F by Euclid Algorithm by using colour ribbon or grid paper.





What we have discussed

1. Division Algorithm: Given positive integers a and b , there exist whole numbers q and r satisfying $a = bq + r$, $0 \leq r < b$.
2. The Fundamental Theorem of Arithmetic states that composite number can be expressed (factorized) as a product of primes and this factorization is unique, apart from the order in which the prime factors occur.
3. If p is a prime and p divides a^2 , where a is a positive integer, then p divides a .
4. Let x be a rational number whose decimal expansion terminates. Then we can express x in the form of $\frac{p}{q}$, where p and q are coprime and the prime factorization of q is of the form $2^n 5^m$, where n and m are non-negative integers.
5. Let $x = \frac{p}{q}$ be a rational number such that the prime factorization of q is of the form $2^n 5^m$, where n and m are non-negative integers. Then x has a decimal expansion which terminates.
6. Let $x = \frac{p}{q}$ be a rational number such that the prime factorization of q is not of the form $2^n 5^m$, where n and m are non-negative integers. Then x has a decimal expansion which is non-terminating and repeating (recurring).
7. We define $\log_a x = n$, if $a^n = x$, where a and x are positive numbers and $a \neq 1$.
8. Laws of logarithms :
If a, x and y are positive real numbers and $a \neq 1$, then
 - (i) $\log_a xy = \log_a x + \log_a y$
 - (ii) $\log_a \frac{x}{y} = \log_a x - \log_a y$
 - (iii) $\log_a x^m = m \log_a x$
 - (iv) $a^{\log_a N} = N$
 - (v) $\log_a 1 = 0$
 - (vi) $\log_a a = 1$
9. Logarithms are enormously used for calculations in engineering, science, business and economics.





2.1 Introduction

When you are asked to describe a person, how would you do it?

Let us see some examples.

Ramanujan was a mathematician, interested in number theory.

Dasarathi was a telugu poet and also a freedom fighter.

Albert Einstein was a physicist who proposed theory of relativity.

Maryam Mirzakhian is the only woman mathematician to win Fields medal.

We classify the individuals first as a member of larger recognizable group then with specific character and interest. People classify and categorize the world around them, in order to make sense of their environment and their relationships to others.

Books in the library are arranged according to the subject, so that we can find them quickly.

In chemistry the elements are categorized in groups and classes to study their general properties

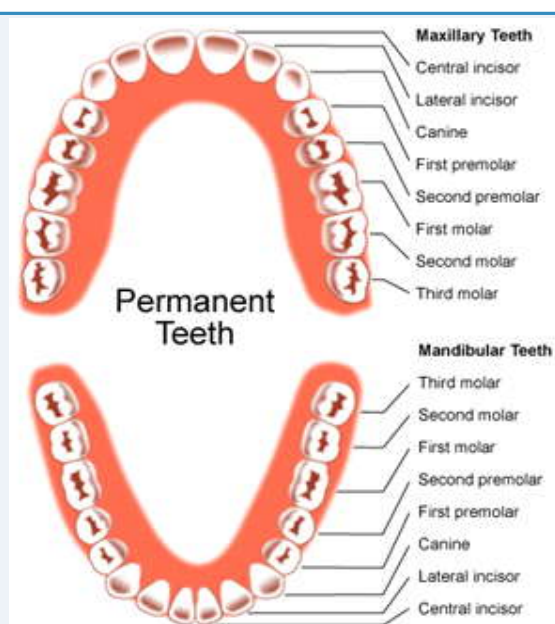
Your mathematics syllabus for tenth class has been divided into 14 chapters under different headings.

Dental Formula

Observe the set of human teeth. It is classified into 4-types according to their functions.

- (i) Incisors (ii) Canines
(iii) Premolars and (iv) Molars

The teeth set is classified into Incisors, Canines, Premolars and Molars on the basis of chewing method. Formula of this teeth set is called 'Dental formula' and it is 2, 1, 2, 3.



Mathematics in this manner is no different from other subjects, it needs to place elements into meaningful groups.

A few examples of such groups of numbers we commonly use in mathematics are

\mathbb{N} = Collection of natural numbers 1, 2, 3....

\mathbb{W} = Collection of whole numbers 0, 1, 2, 3.....

\mathbb{I} or \mathbb{Z} = Collection of Integers 0, ± 1 , ± 2 , ± 3 ,

\mathbb{Q} = Collection of rational numbers i.e the numbers that can be written in $\frac{p}{q}$ form where p, q are integers and $q \neq 0$

\mathbb{R} = Collection of real numbers i.e. the numbers which have decimal expansion.



Do This

Identify and write the “common property” to make meaningful group of the following collections.

- 1) 2,4,6,8,...
- 2) 2,3,5,7,11,...
- 3) 1,4,9,16,...
- 4) January, February, March, April,...
- 5) Thumb, index finger, middle finger, ring finger, little finger.



Think and Discuss

Observe the following collections and prepare as many generalized statements as possible by describing their properties.

- 1) 2,4,6,8,...
- 2) 1,4,9,16,...

2.2 SET

A set is a well-defined collection of distinct objects. The objects in a set are called elements. Sets are written by enclosing all of its elements between the brackets { }.

For example, when we want to write a set of the first five prime numbers, it can be written as $\{2,3,5,7,11\}$ and set of incisors = {central incisor, lateral incisor}





Do This

Write the following sets.

- 1) Set of the first five positive integers.
- 2) Set of multiples of 5 which are more than 100 and less than 125
- 3) Set of first five cubic numbers.
- 4) Set of digits in the Ramanujan number

2.2.1 Roster form and Set builder form

It is difficult to express a set in a long sentence. Therefore, sets are generally denoted by capital letters of English alphabet A, B, C.....

For example, M is the set of molars of our teeth.

We can write this set as $M = \{\text{first molar, second molar, third molar}\}$.

Let us look at another example. Q is the set of quadrilaterals with at least two equal sides. Then, we can write this set as

$Q = \{\text{square, rectangle, rhombus, parallelogram, kite, isosceles trapezium}\}$

Here, we are writing a set by listing the elements in it. In such case, the set is said to be written in the “**roster form**”.

In the above two examples, let us discuss belongingness of the elements and its representation. Suppose, if we want to say “second molar is in the set of molars”, then we can represent this as “second molar $\in M$ ”. And we read this as "second molar belongs to set M"

Can we say “rhombus $\in Q$ ” in the above example of set of quadrilaterals? How do you read this?

Does “square” belong to the set M in the above examples?

Then, how do we denote this? When we say “square is not in the set M”, we denote as “square $\notin M$ ”. And we read this as "square does not belong to the set M".

Recall from the classes you have studied earlier that we denote natural numbers by \mathbb{N} , set of integers by \mathbb{Z} , set of rational numbers by \mathbb{Q} , and set of real numbers by \mathbb{R} .





Do This

Some numbers are given below. Decide which number sets they belong to and do not belong to and express using correct symbols.

- | | | | | |
|----------------|---------------|------------|-------------------|----------------|
| i) 1 | ii) 0 | iii) -4 | iv) $\frac{5}{6}$ | v) $1.\bar{3}$ |
| vi) $\sqrt{2}$ | vii) $\log 2$ | viii) 0.03 | ix) π | x) $\sqrt{-4}$ |



Think and Discuss

Can you write the set of rational numbers in roster form?

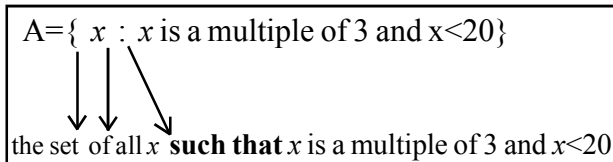
You might have concluded that like natural numbers or integers it is not possible to write the set of rational numbers also by showing list of elements in it. You might have also concluded that all the rational numbers are written in the form of $\frac{p}{q}$ ($q \neq 0$ and p, q are integers).

When we write a set by defining its elements with a “common property”, we can say that the set is in the “set builder form”. Set builder form should follow some syntax.

Let us know it by observing an example.

Suppose A is a set of multiples of 3 less than 20. Then, $A = \{3, 6, 9, 12, 15, 18\}$ is the roster form of the set A. When we write its set builder form, it is

$A = \{x : x \text{ is a multiple of } 3, x < 20\}$ and we read this as “A is the set of elements x such that x is a multiple of 3 and x is less than 20.



Similarly, we can express the rational numbers set as $\mathbb{Q} = \{x : x = \frac{p}{q}, p, q \text{ are integers and } q \neq 0\}$

In the example,

- Note :**
- (i) In roster form, the order in which the elements are listed is **immaterial**. Thus, the set of digits in the Ramanujam number can be written as- $\{7, 2, 1, 9\}$, $\{1, 2, 7, 9\}$ or $\{1, 7, 2, 9\}$ etc.
 - (ii) While writing the elements of a set in roster form, an element is not repeated. For example, the set of letters forming the word “SCHOOL” is $\{s, c, h, o, l\}$ and not $\{s, c, h, o, o, l\}$. Therefore a set contains distinct elements.



Let us observe "roster form" and "set builder form" of some sets given below.

Roster form	Set builder form
$V = \{a, e, i, o, u\}$	$V = \{x : x \text{ is a vowel in the english alphabet}\}$
$A = \{-2, -1, 0, 1, 2\}$	$A = \{x : -2 \leq x \leq 2, x \in \mathbb{Z}\}$
$B = \{1, \frac{1}{2}, \frac{1}{3}, \frac{1}{4}, \frac{1}{5}\}$	$B = \{x : x = \frac{1}{n}, n \in \mathbb{N}, n \leq 5\}$
$C = \{2, 5, 10, 17\}$	$C = \{x : x = n^2 + 1, n \in \mathbb{N}, n \leq 4\}$



Do This

- List the elements of the following sets.
 - $G = \{\text{all the factors of } 20\}$
 - $F = \{\text{the multiples of } 4 \text{ between } 17 \text{ and } 61 \text{ which are divisible by } 7\}$
 - $S = \{x : x \text{ is a letter in the word 'MADAM'}\}$
 - $P = \{x : x \text{ is a whole number between } 3.5 \text{ and } 6.7\}$
- Write the following sets in the roster form.
 - B is the set of all months in a year having 30 days.
 - P is the set of all prime numbers smaller than 10.
 - X is the set of the colours of the rainbow
- A is the set of factors of 12. Represent which one of the following is a member of A and which is not?

(A) 1 (B) 4 (C) 5 (D) 12



Try This

- Write some sets of your choice, involving algebraic and geometrical ideas.
- Match roster forms with the set builder form.

(i) $\{p, r, i, n, c, a, l\}$	(a) $\{x : x \text{ is a positive integer and is a divisor of } 18\}$
(ii) $\{0\}$	(b) $\{x : x \text{ is an integer and } x^2 - 9 = 0\}$
(iii) $\{1, 2, 3, 6, 9, 18\}$	(c) $\{x : x \text{ is an integer and } x + 1 = 1\}$
(iv) $\{3, -3\}$	(d) $\{x : x \text{ is a letter of the word PRINCIPAL}\}$





Exercise - 2.1

- Which of the following are sets? Justify your answer.
 - The collection of all the months of a year beginning with the letter ‘J’.
 - The collection of ten most talented writers of India.
 - A team of eleven best cricket batsmen of the world.
 - The collection of all boys in your class.
 - The collection of all even integers.
- If $A = \{0, 2, 4, 6\}$, $B = \{3, 5, 7\}$ and $C = \{p, q, r\}$, then fill the appropriate symbol, \in or \notin in the blanks.
 - $0 \dots A$
 - $3 \dots C$
 - $4 \dots B$
 - $8 \dots A$
 - $p \dots C$
 - $7 \dots B$
- Express the following statements using symbols.
 - The element ‘x’ does not belong to ‘A’.
 - ‘d’ is an element of the set ‘B’.
 - ‘1’ belongs to the set of Natural numbers.
 - ‘8’ does not belong to the set of prime numbers P.
- State whether the following statements are true or false. Justify your answer
 - $5 \notin$ set of prime numbers
 - $S = \{5, 6, 7\}$ implies $8 \in S$.
 - $-5 \notin W$ where ‘W’ is the set of whole numbers
 - $\frac{8}{11} \in \mathbb{Z}$ where ‘ \mathbb{Z} ’ is the set of integers.
- Write the following sets in roster form.
 - $B = \{x : x \text{ is a natural number smaller than } 6\}$
 - $C = \{x : x \text{ is a two-digit natural number such that the sum of its digits is } 8\}$.
 - $D = \{x : x \text{ is a prime number which is a divisor of } 60\}$.
 - $E = \{x : x \text{ is an alphabet in BETTER}\}$.
- Write the following sets in the set-builder form.
 - $\{3, 6, 9, 12\}$
 - $\{2, 4, 8, 16, 32\}$
 - $\{5, 25, 125, 625\}$
 - $\{1, 4, 9, 16, 25, \dots, 100\}$
- Write the following sets in roster form.
 - $A = \{x : x \text{ is a natural number greater than } 50 \text{ but smaller than } 100\}$
 - $B = \{x : x \text{ is an integer, } x^2 = 4\}$
 - $D = \{x : x \text{ is a letter in the word “LOYAL”}\}$
 - $E = \{x : x = 2n^2 + 1, -3 \leq n \leq 3, n \in \mathbb{Z}\}$



8. Match the roster form with set builder form.

- | | |
|------------------------------------|---|
| (i) $\{1, 2, 3, 6\}$ | (a) $\{x : x \text{ is prime number and a divisor of } 6\}$ |
| (ii) $\{2, 3\}$ | (b) $\{x : x \text{ is an odd natural number smaller than } 10\}$ |
| (iii) $\{m, a, t, h, e, i, c, s\}$ | (c) $\{x : x \text{ is a natural number and divisor of } 6\}$ |
| (iv) $\{1, 3, 5, 7, 9\}$ | (d) $\{x : x \text{ is a letter of the word MATHEMATICS}\}$ |

2.3 Empty Set

Let us consider the following examples of sets:

- (i) $A = \{x : x \text{ is a natural number smaller than } 1\}$
- (ii) $D = \{x : x \text{ is an odd number divisible by } 2\}$

How many elements are there in sets A and D? We know that there is no natural number which is smaller than 1. So set A contains no elements or we can say that A is an *empty set*. Similarly, there are no odd numbers that are divisible by 2. So, D is also an *empty set*.

A set which does not contain any element is called an **empty set**, or a **Null set**, or a **void set**. Empty set is denoted by the symbol ϕ or $\{\}$.

Here are some more examples of empty sets.

- (i) $A = \{x : 1 < x < 2, x \text{ is a natural number}\}$
- (ii) $B = \{x : x^2 - 2 = 0 \text{ and } x \text{ is a rational number}\}$
- (iii) $D = \{x : x^2 = 4, x \text{ is an odd number}\}$

Note: ϕ and $\{0\}$ are two different sets. $\{0\}$ is a set containing an element 0 while ϕ or $\{\}$ has no elements (null set).



Do These

1. Which of the following are empty sets? Justify your answer.
 - (i) Set of integers which lie between 2 and 3.
 - (ii) Set of natural numbers that are smaller than 1.
 - (iii) Set of odd numbers that leave remainder zero, when divided by 2.





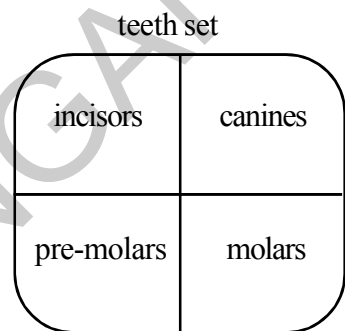
Try This

1. Which of the following sets are empty sets? Justify your answer.
 - (i) $A = \{x : x^2 = 4 \text{ and } 3x = 9\}$.
 - (ii) The set of all triangles in a plane having the sum of their three angles less than 180.

2.4 Universal Set

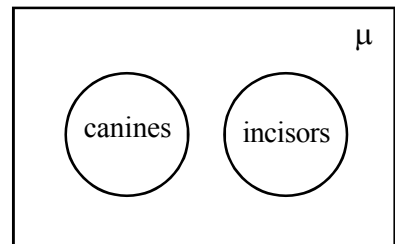
Consider the teeth set that we had discussed in the beginning of the chapter. You had classified the whole teeth set into four smaller sets namely incisors, canines, premolars and molars.

But, are teeth in the set of molars also members of the whole teeth set? or not?



Here, whole teeth set is the "**universal set**" of above said four teeth sets.

Consider the teeth set as universal set and canines, incisors are two sets within it. Then we can represent this as shown in the adjacent diagram also.



Observe the diagram. What does the remaining empty part of the diagram represents?

Let us see more examples of universal sets:

- (i) If we want to study the various groups of people of our state (may be according to income or work or caste), universal set is the set of all people in Telangana.
- (ii) If we want to study the various groups of people in our country, universal set is the set of all people in India.

The universal set is generally denoted by ' μ ' and sometimes by U . The Universal set is usually represented by in rectangles to show in the form of a figure.

Let us consider the set of natural numbers, $\mathbb{N} = \{1, 2, 3, 4, \dots\}$. Then set of even numbers is formed by some elements of \mathbb{N} . Then \mathbb{N} is universal set for the smaller set of even numbers. Is \mathbb{N} also universal set for the set of odd numbers?

1. When we say "if $x < 3$, then $x < 4$ ", we denote as " $x < 3 \Rightarrow x < 4$ ".
2. When we say " $x - 2 = 5$ if and only if $x = 7$ ", we write this as " $x - 2 = 5 \Leftrightarrow x = 7$ ".



2.4.1 Subset

Consider a set from $A = \{1, 2, 3\}$. How many sets can you form by taking as many elements as you wish from set A?

Now, $\{\}, \{1\}, \{2\}, \{3\}, \{1, 2\}, \{2, 3\}, \{1, 3\}$ and $\{1, 2, 3\}$ are the sets you can form. Can you form any other sets? These sets are called **subsets** of A. If we want to say $\{1, 2\}$ is subset of A, then we denote it as $\{1, 2\} \subset A$. When we consider the subsets of A, we should say $\{1, 2, 3\}$ is also as a subset of A. With $\{\}, \{1\}, \{2\}, \{3\}$ etc including.

If all elements of set A are present in B, then A is said to be subset of B denoted by $A \subseteq B$.

Then we can write as $A \subseteq B \Leftrightarrow "a \in A \Rightarrow a \in B"$, where A and B are two sets.

Let us consider the set of real numbers \mathbb{R} . It has many subsets.

For example, the set of natural numbers $\mathbb{N} = \{1, 2, 3, 4, 5, \dots\}$,

the set of whole numbers $W = \{0, 1, 2, 3, \dots\}$,

the set of integers $\mathbb{Z} = \{\dots, -3, -2, -1, 0, 1, 2, 3, \dots\}$

The set of irrational numbers \mathbb{Q}' is composed of all real numbers which are not rational.

Consider a null set ϕ and a non empty set A. Is ϕ a subset of A? If not ϕ should have an element which is not an element of A. For being an empty set ϕ has no such element, thus $\phi \subset A$.

Null set is a subset of every set.

Is $A \subseteq A$? All elements of LHS set A are also elements of RHS set A. Thus $A \subset A$

Every set is a subset of itself.

Thus, $\mathbb{Q}' = \{x : x \in \mathbb{R} \text{ and } x \notin \mathbb{Q}\}$ i.e., all real numbers that are not rational. e.g. $\sqrt{2}$, $\sqrt{5}$ and π .

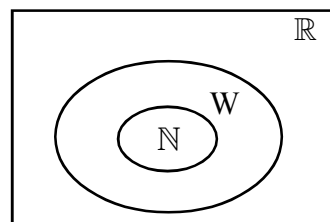
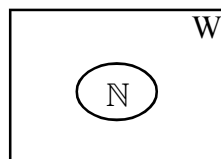
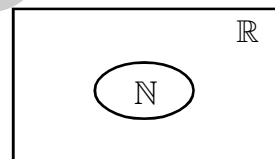
Similarly, the set of natural numbers, \mathbb{N} is a subset of the set of whole numbers W and we can write $\mathbb{N} \subset W$. Also W is a subset of \mathbb{R} .

That is $\mathbb{N} \subset W$ and $W \subset \mathbb{R}$

$$\Rightarrow \mathbb{N} \subset W \subset \mathbb{R}$$

Some of the obvious relations among these subsets are

$\mathbb{N} \subset \mathbb{Z} \subset \mathbb{Q} \subset \mathbb{R}$ and $\mathbb{Q}' \subset \mathbb{R}$, and $\mathbb{N} \not\subset \mathbb{Q}'$.



Consider the set of vowels, $V = \{a, e, i, o, u\}$. Also consider the set A , of all letters in the English alphabet. $A = \{a, b, c, d, \dots, z\}$.

Solution: We can see that every element of set V is also an element A . But there are elements of A which are not a part of V . In this case, V is called the proper subset of A .

In other words $V \subset A$. Since, whenever $a \in V$, then $a \in A$. It can also be denoted by $v \subset A$ and is read as V is the subset of A . The symbol \subset is used to denote proper subset and \subseteq is used to denote subset.



Do This

1. $A = \{1, 2, 3, 4\}$, $B = \{2, 4\}$, $C = \{1, 2, 3, 4, 7\}$, $F = \{ \}$.

Fill in the blanks with \subset or $\not\subset$.

- (i) $A \dots B$ (ii) $C \dots A$ (iii) $B \dots A$
 (iv) $A \dots C$ (v) $B \dots C$ (vi) $\phi \dots B$

2. State which of the following statement are true.

- (i) $\{ \} = \phi$ (ii) $\phi = 0$ (iii) $0 = \{ 0 \}$



Try This

1. $A = \{\text{set all types of quadrilaterals}\}$, $B = \{\text{square, rectangle, trapezium, rhombus}\}$. State whether $A \subset B$ or $B \subset A$. Justify your answer.

2. If $A = \{a, b, c, d\}$. Write all the subsets of set A .

3. P is the set of factors of 5, Q is the set of factors of 25 and R is the set of factors of 125. Which one of the following is false? Explain.

- (A) $P \subset Q$ (B) $Q \subset R$ (C) $R \subset P$ (D) $P \subset R$

4. A is the set of prime numbers less than 10, B is the set of odd numbers less than 10 and C is the set of even numbers less than 10. Which of the following statements are true?

- (i) $A \subset B$ (ii) $B \subset A$ (iii) $A \subset C$
 (iv) $C \subset A$ (v) $B \subset C$ (vi) $\phi \subset A$

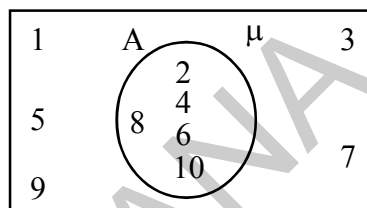


2.5 Venn diagrams

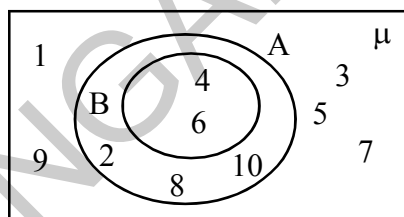
We have already seen different ways of representing sets using diagrams. Let us learn about Venn-Euler diagram or simply Venn-diagram. It is one of the ways of representing the relationships between sets. These diagrams consist of rectangles and closed curves usually circles.

As mentioned earlier in the chapter, the universal set is usually represented by a rectangle.

(i) Consider that $\mu = \{1, 2, 3, \dots, 10\}$ is the universal set of which, $A = \{2, 4, 6, 8, 10\}$ is a subset. Then the Venn-diagram is as:

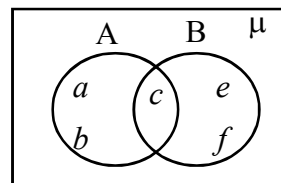


(ii) $\mu = \{1, 2, 3, \dots, 10\}$ is the universal set of which, $A = \{2, 4, 6, 8, 10\}$ and $B = \{4, 6\}$ are subsets and also $B \subset A$. Then, the Venn-diagram is :



(iii) Let $A = \{a, b, c, d\}$ and $B = \{c, d, e, f\}$.

Then we illustrate these sets with a Venn diagram as



2.6 Basic Operations on Sets

We know that arithmetics has operations of addition, subtraction, multiplication and division on numbers. Similarly, we define the operation of union, intersection and difference of sets.

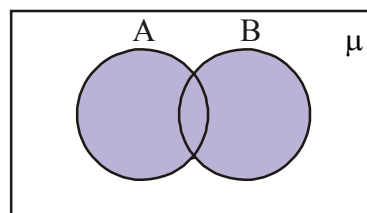
2.6.1 Union of Sets

Let us consider μ , the set of all students in your school.

Suppose A is the set of students in your class who were absent on Tuesday and B is the set of students who were absent on Wednesday. Then,

Let $A = \{\text{Roja, Ramu, Ravi}\}$ and

Let $B = \{\text{Ramu, Preethi, Haneef}\}$



$A \cup B$

Now, we want to find K , the set of students who were absent on either Tuesday or Wednesday. Then, does $\text{Roja} \in K$? $\text{Ramu} \in K$? $\text{Ravi} \in K$? $\text{Haneef} \in K$? $\text{Preethi} \in K$? $\text{Akhila} \in K$?

Roja, Ramu, Ravi, Haneef and Preethi all belong to K but Akhila does not who is always present.

Hence, $K = \{\text{Roja, Ramu, Ravi, Haneef, Preethi}\}$



Here, the set K is called the union of sets A and B . The union of A and B is the set which consists of all the elements of A or B . The symbol \cup is used to denote the union. Union of sets represented in venn-diagram as above (shaded part).

Symbolically, we write $A \cup B$ and usually read as ‘A union B’.

$$A \cup B = \{x : x \in A \text{ or } x \in B\}$$

Example-1. Let $A = \{2, 5, 6, 8\}$ and $B = \{5, 7, 9, 1\}$. Find $A \cup B$.

Solution : We have $A \cup B = \{2, 5, 6, 8\} \cup \{5, 7, 9, 1\} = \{2, 5, 6, 8, 5, 7, 9, 1\}$
 $= \{1, 2, 5, 6, 7, 8, 9\}$.

Note that the common element 5 was taken only once while writing $A \cup B$.

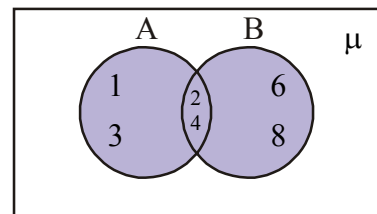
Example-2. Let $A = \{a, e, i, o, u\}$ and $B = \{a, i, u\}$. Show that $A \cup B = A$.

Solution : We have $A \cup B = \{a, e, i, o, u\} \cup \{a, i, u\} = \{a, e, i, o, u, a, i, u\}$
 $= \{a, e, i, o, u\} = A$.

This example illustrates that union of a set A and its subset B is the set A itself i.e, if $B \subset A$, then $A \cup B = A$.

Example-3. If $A = \{1, 2, 3, 4\}$ and $B = \{2, 4, 6, 8\}$. Find $A \cup B$. by venn diagram

Solution : $A = \{1, 2, 3, 4\}$ and $B = \{2, 4, 6, 8\}$
then $A \cup B = \{1, 2, 3, 4\} \cup \{2, 4, 6, 8\}$
 $= \{1, 2, 3, 4, 2, 4, 6, 8\}$
 $= \{1, 2, 3, 4, 6, 8\}$



$$A \cup B = \{1, 2, 3, 4, 6, 8\}$$

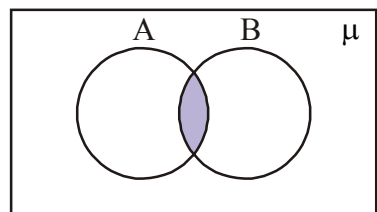
2.6.2 Intersection of Sets

Let us again consider the example of students who were absent. Now let us take the set L that represents the students who were absent on both Tuesday and Wednesday. We find that $L = \{\text{Ramu}\}$.

Here, the set L is called the intersection of sets A and B .

In general, the intersection of sets A and B is the set of all elements which are common in both A and B . i.e., those elements which belong to A and also belong to B . We denote intersection symbolically by as $A \cap B$ (read as ‘‘A intersection B’’). In the figure, $A \cap B$ represented in venn-diagram (shaded part). The intersection of A and B can be illustrated using the Venn-diagram as shown in the shaded portion of the figure, given below, i.e.,

$$A \cap B = \{x : x \in A \text{ and } x \in B\}$$



$$A \cap B$$



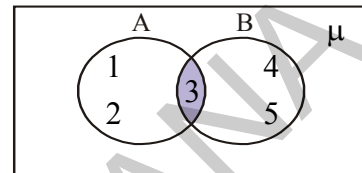
Example-4. Find $A \cap B$ when $A = \{5, 6, 7, 8\}$ and $B = \{7, 8, 9, 10\}$.

Solution : The common elements in both A and B are 7 and 8.

$$\therefore A \cap B = \{5, 6, 7, 8\} \cap \{7, 8, 9, 10\} = \{7, 8\} \quad (\text{common elements})$$

Example-5. If $A = \{1, 2, 3\}$ and $B = \{3, 4, 5\}$, then represent $A \cap B$ in Venn-diagrams.

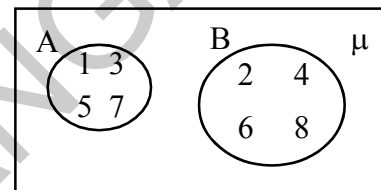
Solution : The intersection of A and B can be represented in the Venn-diagram as shown in the adjacent figure.



$$A \cap B = \{3\}$$

Disjoint Sets

Suppose $A = \{1, 3, 5, 7\}$ and $B = \{2, 4, 6, 8\}$. We see that there are no common elements in A and B. Such sets are known as disjoint sets. The disjoint sets can be represented by means of the Venn-diagram as shown in the adjacent figure:



$$A \cap B = \phi$$



Do This

- Let $A = \{2, 4, 6, 8, 10, 12\}$ and $B = \{3, 6, 9, 12, 15\}$. Find $A \cup B$ and $A \cap B$
- If $A = \{6, 9, 11\}$; $B = \{\}$, find $A \cup \phi$.
- $A = \{1, 2, 3, 4, 5, 6, 7, 8, 9, 10\}$; $B = \{2, 3, 5, 7\}$. Find $A \cap B$.
- If $A = \{4, 5, 6\}$; $B = \{7, 8\}$ then show that $A \cup B = B \cup A$.



Try This

- Write some sets A and B such that A and B are disjoint.
- If $A = \{2, 3, 5\}$, find $A \cup \phi$ and $\phi \cup A$ and comment on results.
- If $A = \{1, 2, 3, 4\}$ and $B = \{1, 2, 3, 4, 5, 6, 7, 8\}$, then find $A \cup B$ and $A \cap B$. What do you notice from the result?
- Let $A = \{1, 2, 3, 4, 5, 6\}$ and $B = \{2, 4, 6, 8, 10\}$. Find the intersection of A and B.





Think & Discuss

The intersection of any two disjoint sets is a null set. Justify your answer.

2.6.3 Difference of Sets

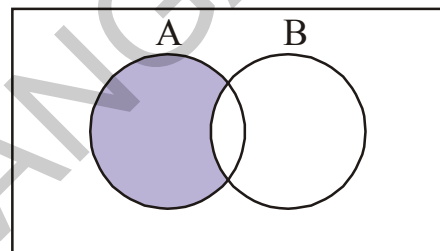
Suppose A is the set of all odd numbers less than 10 and B is the set of prime numbers less than 10. If we consider the set of odd numbers less than 10 which are not prime, then the elements in the set belong to set A, but not to the set B. This set is represented by $A - B$ and read it as A difference B.

$$A = \{1, 3, 5, 7, 9\} \quad B = \{3, 5, 7\}.$$

$$\therefore A - B = \{1, 9\}.$$

Now we define the difference set of sets A and B as **the set of elements which belong to A but do not belong to B**. We denote the difference of A and B by $A - B$ or simply “A minus B”.

$$A - B = \{x : x \in A \text{ and } x \notin B\}.$$



Example-6. Let $A = \{1, 2, 3, 4, 5\}$; $B = \{4, 5, 6, 7\}$. Find $A - B$.

Solution : Given $A = \{1, 2, 3, 4, 5\}$ and $B = \{4, 5, 6, 7\}$. Only the elements which are in A but not in B should be taken.

$$A - B = \{1, 2, 3, 4, 5\} - \{4, 5, 6, 7\} = \{1, 2, 3\}$$

$$\therefore A - B = \{1, 2, 3\}. \quad (\because 4, 5 \text{ are the elements in } B \text{ they are taken away from } A)$$

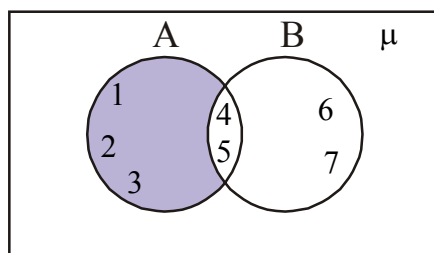
Similarly for $B - A$, the elements which are only in B are taken.

$$B - A = \{4, 5, 6, 7\} - \{1, 2, 3, 4, 5\} = \{6, 7\}$$

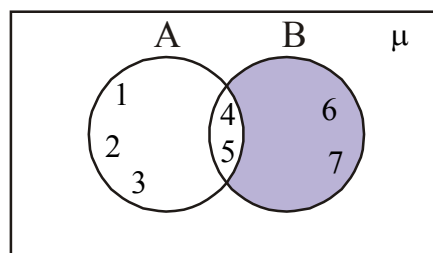
$$\therefore B - A = \{6, 7\} \quad (4, 5 \text{ are the elements in } A \text{ and so they are taken away from } B).$$

Note that $A - B \neq B - A$

The Venn diagram of $A - B$ and $B - A$ are shown below.



$$A - B = \{1, 2, 3\}$$



$$B - A = \{6, 7\}$$





Do This

1. If $A = \{1, 2, 3, 4, 5\}$ and $B = \{4, 5, 6, 7\}$, then find $A - B$ and $B - A$. Are they equal?
2. If $V = \{4, 5, 6, 7, 8, 9\}$ and $B = \{1, 4, 9, 16, 25\}$, find $V - B$ and $B - V$.



Think & Discuss

The sets $A - B$, $B - A$ and $A \cap B$ are mutually disjoint sets. Use examples to observe if this is true.



Exercise - 2.2

1. If $A = \{1, 2, 3, 4\}$ and $B = \{1, 2, 3, 5, 6\}$, then find $A \cap B$ and $B \cap A$. Are they equal?
2. If $A = \{0, 2, 4\}$, find $A \cap \phi$ and $A \cap A$. What did you notice from the result?
3. If $A = \{2, 4, 6, 8, 10\}$ and $B = \{3, 6, 9, 12, 15\}$, find $A - B$ and $B - A$.
4. If A and B are two sets such that $A \subset B$ then what is $A \cup B$? Explain by giving an example.
5. Let $A = \{x : x \text{ is a natural number}\}$
 $B = \{x : x \text{ is an even natural number}\}$
 $C = \{x : x \text{ is an odd natural number}\}$
 $D = \{x : x \text{ is a prime number}\}$
 Find $A \cap B$, $A \cap C$, $A \cap D$, $B \cap C$, $B \cap D$ and $C \cap D$.
6. If $A = \{3, 6, 9, 12, 15, 18, 21\}$, $B = \{4, 8, 12, 16, 20\}$,
 $C = \{2, 4, 6, 8, 10, 12, 14, 16\}$ and $D = \{5, 10, 15, 20\}$, find
 (i) $A - B$ (ii) $A - C$ (iii) $A - D$ (iv) $B - A$ (v) $C - A$
 (vi) $D - A$ (vii) $B - C$ (viii) $B - D$ (ix) $C - B$ (x) $D - B$
7. State whether the following statements is true or false. Justify your answers.
 - (i) $\{2, 3, 4, 5\}$ and $\{3, 6\}$ are disjoint sets.
 - (ii) $\{a, e, i, o, u\}$ and $\{a, b, c, d\}$ are disjoint sets.
 - (iii) $\{2, 6, 10, 14\}$ and $\{3, 7, 11, 15\}$ are disjoint sets.
 - (iv) $\{2, 6, 10\}$ and $\{3, 7, 11\}$ are disjoint sets.



2.7 Equal Sets

Consider the following sets.

$$A = \{\text{Sachin, Dravid, Kohli}\}$$

$$B = \{\text{Dravid, Sachin, Dhoni}\}$$

$$C = \{\text{Kohli, Dravid, Sachin}\}$$

What do you observe in the above three sets A, B and C? All the players that are in A are in C. Also, all the players that are in C are in A. Thus, A and C have same elements but some elements of A and B are different. So, the sets A and C are equal sets but sets A and B are not equal.

Two sets A and C are said to be **equal** if every element in A belongs to C (i.e. $A \subseteq C$) and every element in C belongs to A (i.e. $C \subseteq A$).

If A and C are equal sets, then we write $A = C$. Thus, we can also write that $C \subseteq A$ and $A \subseteq C \Leftrightarrow A = C$. [Here \Leftrightarrow is the symbol for two way implication and is usually read as, **if and only if** (briefly written as “iff”). Every set is a subset to itself.

Example-7. If $A = \{p, q, r\}$ and $B = \{q, p, r\}$, then check whether $A=B$ or not.

Solution : Given $A = \{p, q, r\}$ and $B = \{q, p, r\}$.

In the above sets, every element of A is also an element of B. $\therefore A \subseteq B$.

Similarly every element of B is also in A. $\therefore B \subseteq A$.

Then from the above two relations, we can say $A=B$.

Examples-8. If $A = \{1, 2, 3, \dots\}$ and \mathbb{N} is the set of natural numbers, then check whether A and \mathbb{N} are equal?

Solution : The elements are same in both the sets. Therefore, $A \subseteq \mathbb{N}$ and $\mathbb{N} \subseteq A$.

Therefore, both A and \mathbb{N} are the set of Natural numbers. Therefore the sets A and \mathbb{N} are equal sets i.e. $A = \mathbb{N}$.

Example-9. Consider the sets $A = \{1, 2, 3\}$ and $B = \{1, 2, 3, 4\}$. Are they equal?

Solution : $A \subset B$ but $B \not\subset A$ then $A \neq B$.



Example-10. Let A be the set of prime numbers smaller than 6 and B be the set of prime factors of 30. Check if A and B are equal.

Solution : The set of prime numbers less than 6, $A = \{2,3,5\}$

The prime factors of 30 are 2, 3 and 5. So, $B = \{2,3,5\}$

Since the elements of A are the same as the elements of B and vice versa therefore, A and B are equal. i.e. $A \subseteq B, B \subseteq A \Rightarrow A = B$

Example-11. Show that the sets C and B are equal, where

$C = \{x : x \text{ is a letter in the word 'ASSASSINATION'}\}$

$B = \{x : x \text{ is a letter in the word STATION}\}$

Solution : Given that $C = \{x : x \text{ is a letter in the word 'ASSASSINATION'}\}$

The roster form of the set $C = \{A,S,I,N,T,O\}$, since elements in a set cannot be repeated.

Also given that $B = \{x : x \text{ is a letter in the word STATION}\}$

' B ' can also be written as $B = \{A,S,I,N,T,O\}$

So, the elements of C and B are same and $C = B$.

i.e. $C \subseteq B, B \subseteq C \Rightarrow C=B$

Example-12. Consider the sets $\phi, A = \{1, 3\}, B = \{1, 5, 9\}, C = \{1, 3, 5, 7, 9\}$. Insert the symbol \subset or $\not\subset$ between each of the following pair of sets.

(i) ϕ B (ii) A B (iii) A C (iv) B C

Solution : (i) $\phi \subset B$, as ϕ is a subset of every set.

(ii) $A \not\subset B$, as $3 \in A$ but $3 \notin B$.

(iii) $A \subset C$ as 1, 3 $\in A$ also belong to C .

(iv) $B \subset C$ as every element of B is also an element of C .





Exercise - 2.3

1. Which of the following sets are equal?

$A = \{x : x \text{ is a letter in the word FOLLOW}\}$, $B = \{x : x \text{ is a letter in the word FLOW}\}$
and $C = \{x : x \text{ is a letter in the word WOLF}\}$

2. Consider the following sets and fill up the blanks with = or \neq so as to make the statement true.

$A = \{1, 2, 3\}$;

$B = \{\text{The first three natural numbers}\}$

$C = \{a, b, c, d\}$;

$D = \{d, c, a, b\}$

$E = \{a, e, i, o, u\}$;

$F = \{\text{set of vowels in English Alphabet}\}$

(i) $A \dots B$

(ii) $A \dots E$

(iii) $C \dots D$

(iv) $D \dots F$

(v) $F \dots A$

(vi) $D \dots E$

(vii) $F \dots B$

3. In each of the following, state whether $A = B$ or not.

(i) $A = \{a, b, c, d\}$ $B = \{d, c, a, b\}$

(ii) $A = \{4, 8, 12, 16\}$ $B = \{8, 4, 16, 18\}$

(iii) $A = \{2, 4, 6, 8, 10\}$ $B = \{x : x \text{ is a positive even integer and } x < 10\}$

(iv) $A = \{x : x \text{ is a multiple of } 10\}$ $B = \{10, 15, 20, 25, 30, \dots\}$

4. State the reasons for the following :

(i) $\{1, 2, 3, \dots, 10\} \neq \{x : x \in \mathbb{N} \text{ and } 1 < x < 10\}$

(ii) $\{2, 4, 6, 8, 10\} \neq \{x : x = 2n+1 \text{ and } x \in \mathbb{N}\}$

(iii) $\{5, 15, 30, 45\} \neq \{x : x \text{ is a multiple of } 15\}$

(iv) $\{2, 3, 5, 7, 9\} \neq \{x : x \text{ is a prime number}\}$

5. List all the subsets of the following sets.

(i) $B = \{p, q\}$

(ii) $C = \{x, y, z\}$

(iii) $D = \{a, b, c, d\}$

(iv) $E = \{1, 4, 9, 16\}$

(v) $F = \{10, 100, 1000\}$



2.8 Finite and Infinite sets

Now consider the following sets:

- (i) $A = \{\text{the students of your school}\}$ (ii) $L = \{2,3,5,7\}$
(iii) $B = \{x : x \text{ is an even number}\}$ (iv) $J = \{x : x \text{ is a multiple of } 7\}$

Can you list the number of elements in each of the sets given above? In (i), the number of elements will be the number of students in your school. In (ii), the number of elements in set L is 4. We find that it is possible to express the number of elements of sets A and L in definite whole numbers. Such sets are called **finite sets**.

Now, consider (iii), the set B of all even numbers. Can we count the number of elements in set B? We see that the number of elements in this set is not finite. We find that the number of elements in B is infinite. And, the set J also has infinite number of elements. Such sets are called **infinite sets**.

We can draw infinite number of straight lines passing through a given point. So, this set of straight lines is infinite. Similarly, it is not possible to find out the last number among the collection of all integers. Thus, we can say the set of integers is infinite.

Consider some more examples :

- (i) Let 'W' be the set of the days of the week. Then W is finite.
(ii) Let 'S' be the set of solutions of the equation $x^2 - 16 = 0$. Then S is finite.
(iii) Let 'G' be the set of points on a line. Then G is infinite.

Example-13. State which of the following sets are finite or infinite.

- (i) $\{x : x \in \mathbb{N} \text{ and } (x - 1)(x - 2) = 0\}$ (ii) $\{x : x \in \mathbb{N} \text{ and } x^2 = 4\}$
(iii) $\{x : x \in \mathbb{N} \text{ and } 2x - 2 = 0\}$ (iv) $\{x : x \in \mathbb{N} \text{ and } x \text{ is prime}\}$
(v) $\{x : x \in \mathbb{N} \text{ and } x \text{ is odd}\}$

Solution :

- (i) x can take the values 1 or 2 in the given case. The set is $\{1,2\}$. Hence, it is finite.
(ii) $x^2 = 4$, implies that $x = +2$ or -2 . But $x \in \mathbb{N}$ or x is a natural number so the set is $\{2\}$. Hence, it is finite.



- (iii) In the given set $x = 1$ and $1 \in \mathbb{N}$. Hence, it is finite.
- (iv) The given set is the set of all prime numbers. There are infinitely many prime numbers. Hence, set is infinite.
- (v) Since there are infinite number of odd numbers, hence the set is infinite.

2.9 Cardinality of a finite set

Now, consider the following finite sets :

$$A = \{1, 2, 4\}; B = \{6, 7, 8, 9, 10\}; C = \{x : x \text{ is an alphabet in the word "INDIA"}\}$$

Here, Number of elements in set $A = 3$. Number of elements in set $B = 5$.

Number of elements in set C is 4 (In the set C , the element 'I' repeats twice. We know that the elements of a given set should be distinct. So, the number of distinct elements in set C is 4).

The number of elements in a finite set is called the cardinal number of the set or the cardinality of the set.

The cardinal number or cardinality of the set A is denoted as $n(A) = 3$.

Similarly, $n(B) = 5$ and $n(C) = 4$.

For finite set cardinality is a whole number. We will learn cardinality of infinite sets in higher classes.

Note : There are no elements in a null set. The cardinal number of that set is '0'. $\therefore n(\phi) = 0$



Do These

1. State which of the following sets are finite and which are infinite. Give reasons for your answer.

(i) $A = \{x : x \in \mathbb{N} \text{ and } x < 100\}$	(ii) $B = \{x : x \in \mathbb{N} \text{ and } x \leq 5\}$
(iii) $C = \{1^2, 2^2, 3^2, \dots\}$	(iv) $D = \{1, 2, 3, 4\}$
(v) $\{x : x \text{ is a day of the week}\}$.	
2. Tick the set which is infinite

(A) The set of whole numbers < 10	(B) The set of prime numbers < 10
(C) The set of integers < 10	(D) The set of factors of 10





Think & Discuss

An empty set is a finite set. Is this statement true or false? Why?



Exercise - 2.4

1. State which of the following sets are empty and which are not?
 - (i) The set of lines passing through a given point.
 - (ii) Set of odd natural numbers divisible by 2.
 - (iii) $\{x : x \text{ is a natural number, } x < 5 \text{ and } x > 7\}$
 - (iv) $\{x : x \text{ is a common point to any two parallel lines}\}$
 - (v) Set of even prime numbers.
2. State whether the following sets are finite or infinite.
 - (i) The set of months in a year.
 - (ii) $\{1, 2, 3, \dots, 99, 100\}$
 - (iii) The set of prime numbers smaller than 99.
 - (iv) The set of letters in the English alphabet.
 - (v) The set of lines that can be drawn parallel to the X-Axis.
 - (vi) The set of numbers which are multiples of 5.
 - (vii) The set of circles passing through the origin $(0, 0)$.

Example-14. If $A = \{1, 2, 3, 4, 5\}$; $B = \{2, 4, 6, 8\}$ then find $n(A \cup B)$.

Solution : The set A contains five elements $\therefore n(A) = 5$

and the set B contains four elements $\therefore n(B) = 4$

But $A \cup B = \{1, 2, 3, 4, 5, 6, 8\}$ does not contain 9 elements and it contains only 7 elements. Why?



Think & discuss

1. What is the relation between $n(A)$, $n(B)$, $n(A \cap B)$ and $n(A \cup B)$?
2. If A and B are disjoint sets, then how can you find $n(A \cup B)$?



Suggested Projects

- Conduct a survey in your classroom. Ask your classmates whether they like cricket or badminton (or choose any other two games)/ newspapers / TV channels etc.

By using sets, find out

- (i) How many are interested in game1/ newspaper1/ TV channel1?
- (ii) How many are interested in game2/ newspaper2/ TV channel2?
- (iii) How many are interested in both? and
- (iv) How many are interested in neither?

Extension: We can extend the above survey for three games/ newspapers/ TV channels etc.



What We Have Discussed



1. A set is a collection of distinct objects. A well defined set means that:
 - (i) there is a universe of objects which are taken into consideration.
 - (ii) any object in the universe is either an element or is not an element of the set.
2. An object belonging to a set is known as an element of the set. We use the symbol \in to denote membership of an element and read as belongs to.
3. Sets can be written in the roster form where all elements of the set are written, separated by commas, within curly brackets (braces).
4. Sets can also be written in the set-builder form. Where the elements are defined using a common property.
5. A set which does not contain any element is called an **empty** set, or a **Null** set, or a **void** set.
6. A set is called a finite set if its cardinality/ cardinal number is a whole number.
7. We can say that a set is infinite if it is not finite.



8. The number of elements in a finite set is called the cardinal number/ cardinality of the set.
9. The universal set is denoted by ' μ ' or U . The universal set is usually represented by rectangles.
10. A is a subset of B if ' a ' is an element of A implies that ' a ' is also an element of B . This is written as $A \subset B$ if $a \in A \Rightarrow a \in B$, where A, B are two sets.
11. Two sets, A and B are said to be **equal** if every element in A belongs to B and every element in B belongs to A .
12. A union B is written as $A \cup B = \{x : x \in A \text{ or } x \in B\}$.
13. A intersection B is written as $A \cap B = \{x : x \in A \text{ and } x \in B\}$
14. The difference of two sets A, B is defined as $A - B$
 $A - B = \{x : x \in A \text{ and } x \notin B\}$
15. Venn diagrams are a convenient way of showing operations between sets.





3.1 Introduction

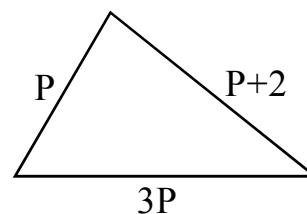
We have already learnt about Polynomials in class IX. We will do some more work with them. Let us observe the following two situations.

1. A flower bed in a garden is in the shape of a triangle. The longest side is 3 times the smallest side and the smallest side is 2 units shorter than the intermediate side. Let P represent the length of the smallest side. Then what is the perimeter in terms of P ?

There is an "unknown" in the above situation. Let this unknown "the smallest side" is given as ' P ' units.

Since, Perimeter of triangle = sum of all sides

$$\begin{aligned} \text{Perimeter} &= P + 3P + P + 2 \\ &= 5P + 2 \end{aligned}$$



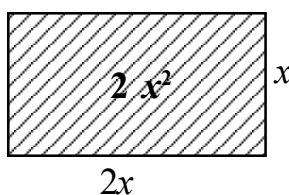
2. The length of a rectangular dining hall is twice its breadth. Let x represents the breadth of the hall. What is the area of the floor of the hall in terms of x ?

In this, the length is given as twice the breadth.

So, if breadth = x , then length = $2x$

Since area of rectangle = lb

$$\begin{aligned} \text{Area} &= (2x)(x) \\ &= 2x^2 \end{aligned}$$



As we know, the perimeter, $5P + 2$ of the triangle and the area $2x^2$ of the rectangle are in the form of polynomials of different degrees.



3.2 What are Polynomials?

A polynomial in x is an Algebraic expression containing the sum of a finite number of terms of the form ax^n for a real number a , where $a \neq 0$ and a whole number n .

Polynomials	Not polynomials
$2x$	$4x^{\frac{1}{2}}$
$\frac{1}{3}x - 4$	$3x^2 + 4x^{-1} + 5$
$x^2 - 2x - 1$	$4 + \frac{1}{x}$



Do This

State which of the following are polynomials and which are not? Give reasons.

- (i) $2x^3$ (ii) $\frac{1}{x} - 1$ ($x \neq 0$) (iii) $4z^2 + \frac{1}{7}$ (iv) $m^2 - \sqrt{2}m + 2$ (v) $P^{-2} + 1$

3.2.1 Degree of a Polynomial

Recall that if $p(x)$ is a polynomial in x , the highest power of x in $p(x)$ is called the degree of the polynomial $p(x)$. For example, $3x + 5$ is a polynomial in the variable x . It is a polynomial of degree 1 and is called a linear polynomial. $5x$, $\sqrt{2}y + 5$, $\frac{1}{3}P$, $m + 1$ etc. are some more linear polynomials. A polynomial of degree 2 is called a quadratic polynomial.

For example, $x^2 + 5x + 4$ is a quadratic polynomial in the variable x . $2x^2 + 3x - \frac{1}{2}$, $p^2 - 1$, $3 - z - z^2$, $y^2 - \frac{y}{3} + \sqrt{2}$ are some examples of quadratic polynomials.

The expression $5x^3 - 4x^2 + x - 1$ is a polynomial in the variable x of degree 3, and is called a cubic polynomial. Some more examples of cubic polynomials are $2 - x^3$, p^3 , $\ell^3 - \ell^2 - \ell + 5$.

6 can be written as $6 \times x^0$. As the index of x is 0, it is a polynomial of 0 degree.



Try This

Write 3 different quadratic, cubic and 2 linear polynomials with different number of terms.

We can write polynomials of any degree.

$7u^6 - \frac{3}{2}u^4 + 4u^2 - 8$ is polynomial of degree 6 and $x^{10} - 3x^8 + 4x^5 + 2x^2 - 1$ is a polynomial of degree 10.

We can write a polynomial in a variable x of a degree n where n is any whole number.



Generally, we say

$p(x) = a_0 x^n + a_1 x^{n-1} + a_2 x^{n-2} + \dots + a_{n-1} x + a_n$ is a polynomial of n^{th} degree in variable x , where $a_0, a_1, a_2, \dots, a_{n-1}, a_n$ are real coefficients of x and $a_0 \neq 0$

For example, the general form of a linear polynomial (degree 1) in one variable x is $ax+b$, where a and b are real numbers and $a \neq 0$.



Try This

1. Write the general form of a quadratic polynomial and a cubic polynomial in variable x .
2. Write a general polynomial $q(z)$ of degree n with coefficients that are $b_0, b_1, b_2, \dots, b_n$. What are the conditions on $b_0, b_1, b_2, \dots, b_n$?

3.2.2 Value of a Polynomial

Now, consider the polynomial $p(x) = x^2 - 2x - 3$. What is the value of the polynomial at any value of x ? For example, what is its value at $x = 1$? Substituting $x = 1$, in the polynomial, we get $p(1) = (1)^2 - 2(1) - 3 = -4$. The value -4 , is obtained by replacing x by 1 in the given polynomial $p(x)$. -4 is the value of $x^2 - 2x - 3$ at $x = 1$.

Similarly, $p(0) = -3$, then, -3 is the value of $p(x)$ at $x = 0$.

Thus, if $p(x)$ is a polynomial in x , and if k is a real number, then the value obtained by substituting $x = k$ in $p(x)$ is called the value of $p(x)$ at $x = k$ and is denoted by $p(k)$.



Do This

- (i) If $p(x) = x^2 - 5x - 6$, then find the values of $p(1), p(2), p(3), p(0), p(-1), p(-2), p(-3)$.
- (ii) If $p(m) = m^2 - 3m + 1$, then find the value of $p(1)$ and $p(-1)$.

3.2.3 Zeroes of a Polynomial

What are the values of $p(x) = x^2 - 2x - 3$ at $x = 3, -1$ and 2 ?

We have, $p(3) = (3)^2 - 2(3) - 3 = 9 - 6 - 3 = 0$

also $p(-1) = (-1)^2 - 2(-1) - 3 = 1 + 2 - 3 = 0$

and $p(2) = (2)^2 - 2(2) - 3 = 4 - 4 - 3 = -3$



We see that $p(3) = 0$ and $p(-1) = 0$. 3 and -1 are called **Zeroes** of the polynomial $p(x) = x^2 - 2x - 3$.

2 is not zero of $p(x)$, since $p(2) \neq 0$

More generally, a real number k is said to be a zero of a polynomial $p(x)$, if $p(k) = 0$.



Do This

- (i) Let $p(x) = x^2 - 4x + 3$. Find the value of $p(0)$, $p(1)$, $p(2)$, $p(3)$ and obtain zeroes of the polynomial $p(x)$.
- (ii) Check whether -3 and 3 are the zeroes of the polynomial $x^2 - 9$.



Exercise - 3.1

1. In $p(x) = 5x^7 - 6x^5 + 7x - 6$, then find the following
 - (i) coefficient of x^5
 - (ii) degree of $p(x)$
 - (iii) constant term.
2. State which of the following statements are true and which are false? Give reasons for your choice.
 - (i) The degree of the polynomial $\sqrt{2}x^2 - 3x + 1$ is $\sqrt{2}$.
 - (ii) The coefficient of x^2 in the polynomial $p(x) = 3x^3 - 4x^2 + 5x + 7$ is 2.
 - (iii) The degree of a constant term is zero.
 - (iv) $\frac{1}{x^2 - 5x + 6}$ is a quadratic polynomial.
 - (v) The degree of a polynomial is one more than the number of terms in it.
3. If $p(t) = t^3 - 1$, find the values of $p(1)$, $p(-1)$, $p(0)$, $p(2)$, $p(-2)$.
4. Check whether -2 and 2 are the zeroes of the polynomial $x^4 - 16$.
5. Check whether 3 and -2 are the zeroes of the polynomial $p(x)$ when $p(x) = x^2 - x - 6$.

3.3 Working with Polynomials

You have already learnt how to find the zeroes of a linear polynomial.

For example, if k is a zero of $p(x) = 2x + 5$, then $p(k) = 0$ gives $2k + 5 = 0 \therefore k = \frac{-5}{2}$.



In general, if k is a zero of $p(x) = ax + b$ ($a \neq 0$), then $p(k) = ak + b = 0$,

Therefore $k = \frac{-b}{a}$, or the zero of the linear polynomial $ax + b$ is $\frac{-b}{a}$.

Thus, the zero of a linear polynomial is related to its coefficients, including the constant term.

3.4 Geometrical Meaning of the Zeroes of a Polynomial

You know that a real number k is a zero of the polynomial $p(x)$ if $p(k) = 0$. Let us see the **graphical** representations of linear and quadratic polynomials and the geometrical meaning of their zeroes.

3.4.1. Graphical representation of a linear polynomial

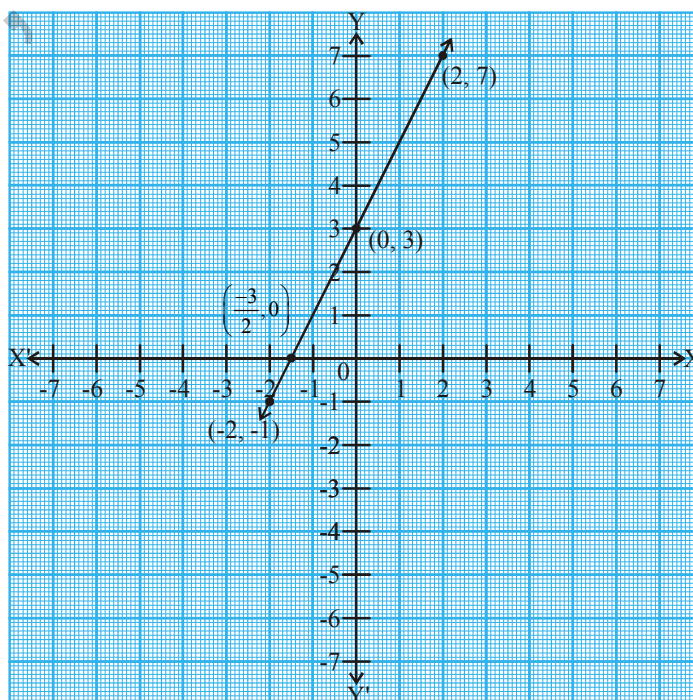
Consider first a linear polynomial $ax + b$ ($a \neq 0$). You have studied in Class-IX that the graph of $y = ax + b$ is a straight line. For example, the graph of $y = 2x + 3$ is a straight line intersecting the Y -axis at $(0, 3)$ and it also passes through the points $(-2, -1)$ and $(2, 7)$.

Table 3.1

x	-2	-1	0	2
$y = 2x + 3$	-1	1	3	7
(x, y)	$(-2, -1)$	$(-1, 1)$	$(0, 3)$	$(2, 7)$

In the graph, you can see that the graph of $y = 2x + 3$ intersects the X -axis between $x = -1$ and $x = -2$, that is, at the point $(\frac{-3}{2}, 0)$. So, $x = \frac{-3}{2}$ is the zero of the polynomial $2x + 3$.

Thus, the zero of the polynomial $2x + 3$ is the x -coordinate of the point where the graph of $y = 2x + 3$ intersects the X -axis.





Do This

Draw the graph of (i) $y = 2x + 5$, (ii) $y = 2x - 5$, (iii) $y = 2x$ and find the point of intersection on X-axis. Is the x -coordinate of these points also the zero of the polynomials?

In general, for a linear polynomial $ax + b$, $a \neq 0$, the graph of $y = ax + b$ is a straight line which intersects the X -axis at exactly one point, namely, $(\frac{-b}{a}, 0)$.

Therefore, the linear polynomial $ax + b$, $a \neq 0$, has exactly one zero, namely, the x -coordinate of the point where the graph of $y = ax + b$ intersects the X -axis. This point of intersection of the straight line with X -axis, as we know is $\frac{-b}{a}$.

3.4.2. Graphical Representation of a Quadratic Polynomial

Now, let us look for the geometrical meaning of a zero of a quadratic polynomial. Consider the quadratic polynomial $x^2 - 3x - 4$. Let us see how the graph of $y = x^2 - 3x - 4$ looks like. Let us list a few values of $y = x^2 - 3x - 4$ corresponding to a few values for x as given in Table 3.2.

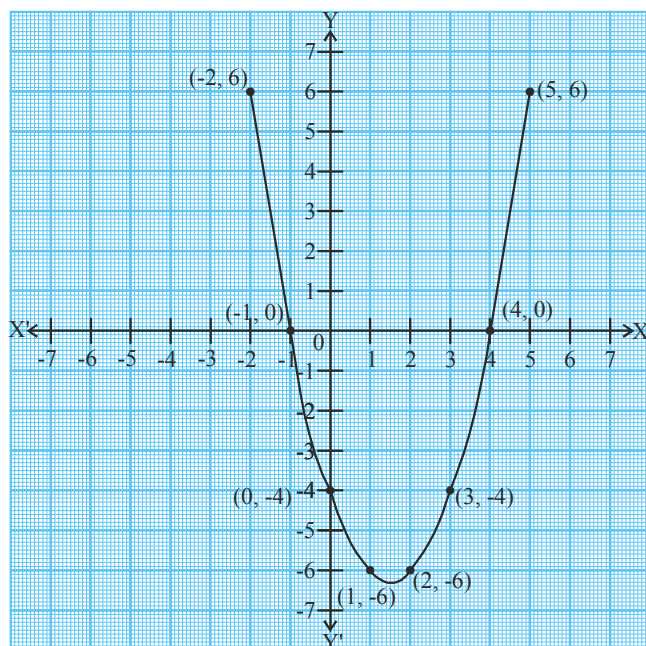
Table 3.2

x	-2	-1	0	1	2	3	4	5
$y = x^2 - 3x - 4$	6	0	-4	-6	-6	-4	0	6
(x, y)	(-2, 6)	(-1, 0)	(0, -4)	(1, -6)	(2, -6)	(3, -4)	(4, 0)	(5, 6)

We locate the points listed above on a graph paper and join the points with a smooth curve.

Is the graph of $y = x^2 - 3x - 4$ a straight line? No, it is like a \cup shaped curve. It is intersecting the X -axis at two points.

In fact, for any quadratic polynomial $ax^2 + bx + c$, $a \neq 0$, the graph of the corresponding equation $y = ax^2 + bx + c$. ($a \neq 0$) either opens upwards like \cup or downwards like \cap . This depends on whether $a > 0$ or $a < 0$. (The shape of such curves are called **parabolas**.)



From the table, we observe that -1 and 4 are zeroes of the quadratic polynomial. From the graph, we see that -1 and 4 are the x -coordinates of points of intersection of the parabola with the X -axis. Zeroes of the quadratic polynomial $x^2 - 3x - 4$ are the x -coordinates of the points where the graph of $y = x^2 - 3x - 4$ intersects the X -axis.

For the polynomial $p(x) = y = x^2 - 3x - 4$; the curve intersects the X -axis at $(-1, 0)$ which means $p(-1)=0$ and since $p(4)=0$ the curve intersects the X -axis at $(4, 0)$. In general for polynomial $p(x)$ if $p(a)=0$, its graph intersects X -axis at $(a, 0)$.

This is true for any quadratic polynomial, i.e., the zeroes of a quadratic polynomial $ax^2 + bx + c$, ($a \neq 0$) are precisely the x -coordinates of the points where the parabola representing $y = ax^2 + bx + c$ ($a \neq 0$) intersects the X -axis.

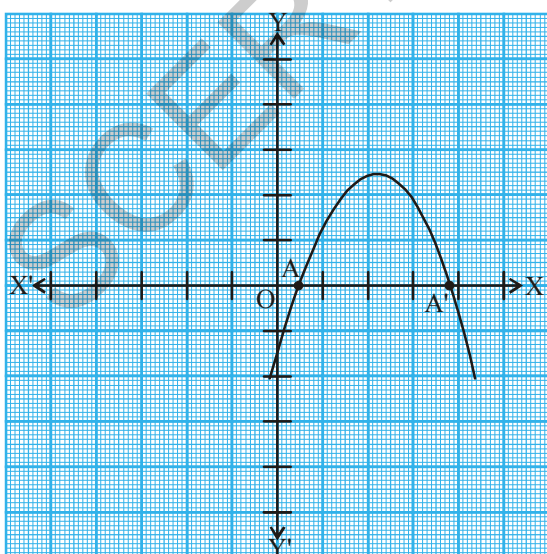


Try This

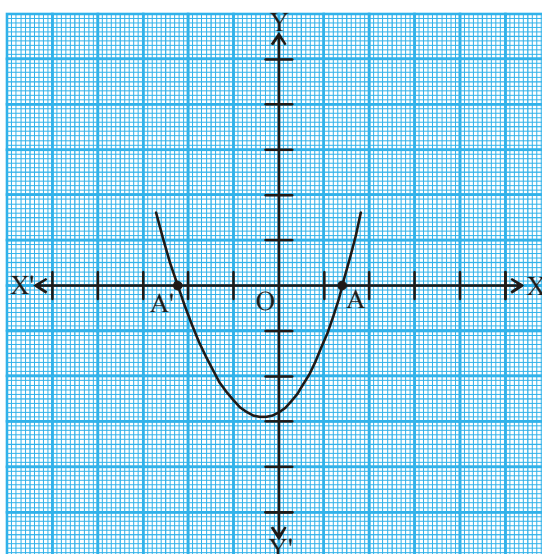
Draw the graphs of (i) $y = x^2 - x - 6$ (ii) $y = 6 - x - x^2$ and find zeroes in each case. What do you notice?

From our earlier observation about the shape of the graph of $y = ax^2 + bx + c$, ($a \neq 0$) the following three cases arise.

Case (i) : The curve cuts X -axis at two distinct points A and A' . In this case, the x -coordinates of A and A' are the **two zeroes** of the quadratic polynomial $ax^2 + bx + c$ irrespective of whether the parabola opens upward or downward.



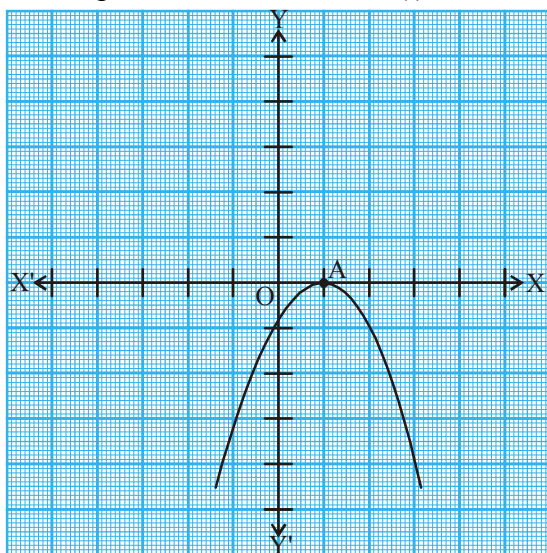
(i)



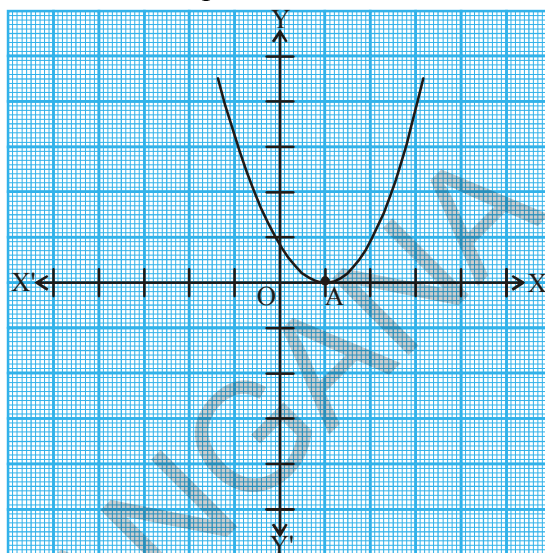
(ii)



Case (ii) : Here, the curve touches X -axis at exactly one point, i.e., at two coincident points. So, the two points A and A' of Case (i) coincide here to become one point A .



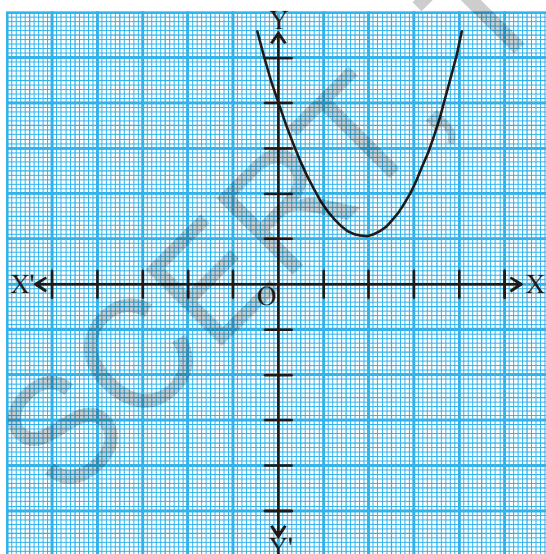
(i)



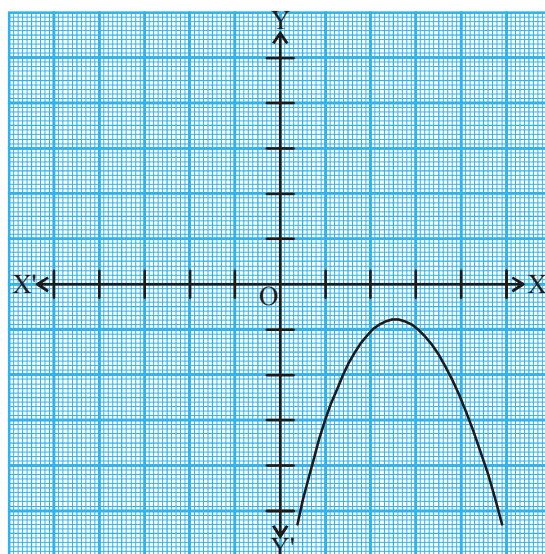
(ii)

In this case, the x -coordinate of A is the **only zero** for the quadratic polynomial $ax^2 + bx + c$.

Case (iii) : Here, the curve is either completely above the X -axis or completely below the X -axis without intersecting X -axis.



(i)



(ii)

So, the quadratic polynomial $ax^2 + bx + c$ has **no zero** in this case.

So, you can see geometrically that a quadratic polynomial can have either two distinct zeroes or two equal zeroes (i.e., one zero), or no zero. This also means that a polynomial of degree 2 has at most two zeroes.





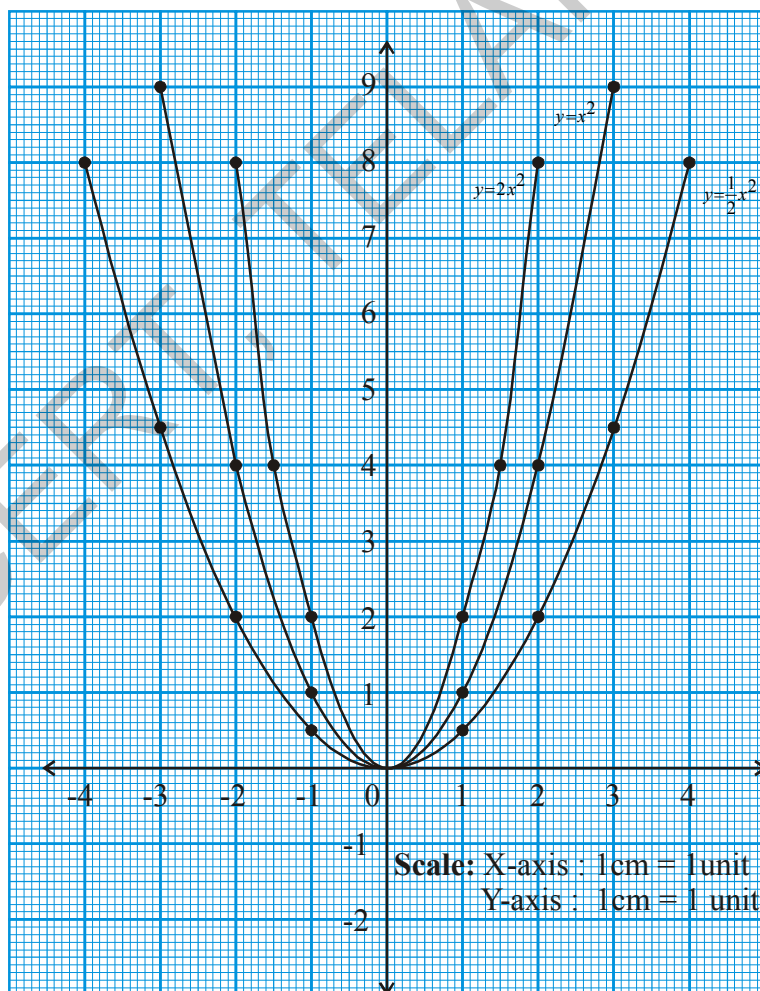
Try This

1. Write three quadratic polynomials that have 2 zeroes each.
2. Write one quadratic polynomial that has one zero.
3. How will you verify if a quadratic polynomial has only one zero?
4. Write three quadratic polynomials that have no zeroes.



Think & Discuss

Observe the curves in the graph given below. They represent $y = \frac{1}{2}x^2$, $y = x^2$ and $y = 2x^2$. Try to plot some more graphs for $y = x^2 + 1$, $y = 2x^2 + 1$. Comment on your observations.



3.4.3 Geometrical Meaning of Zeroes of a Cubic Polynomial

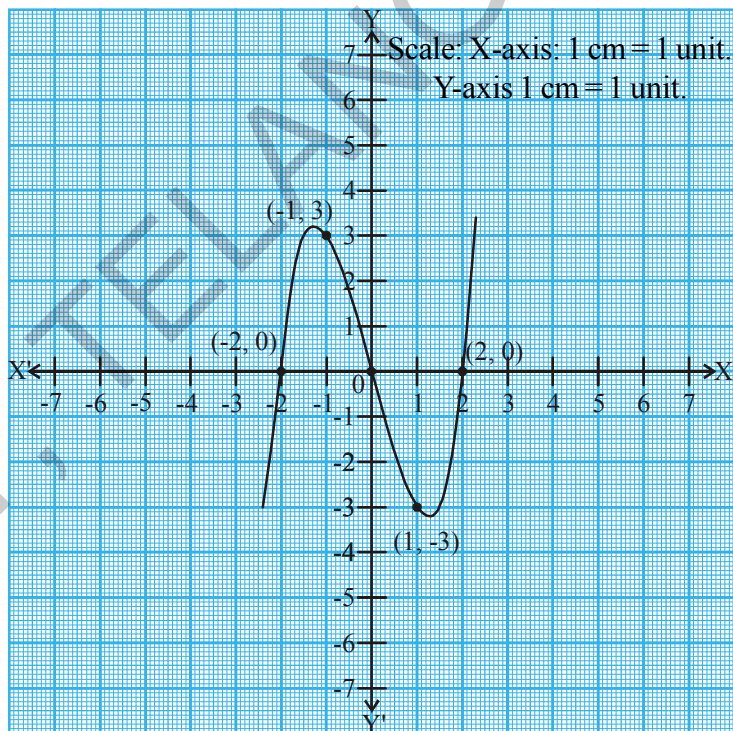
What do you expect the geometrical meaning of the zeroes of a cubic polynomial to be? Let us find out. Consider the cubic polynomial $x^3 - 4x$. To see how the graph of $y = x^3 - 4x$ looks like, let us list a few values of y corresponding to a few values for x as shown in Table 3.3.

Table 3.3

x	-2	-1	0	1	2
$y = x^3 - 4x$	0	3	0	-3	0
(x, y)	$(-2, 0)$	$(-1, 3)$	$(0, 0)$	$(1, -3)$	$(2, 0)$

If we see the graph of $y = x^3 - 4x$, it looks like the one given in the figure.

We see from the table above that $-2, 0$ and 2 are zeroes of the cubic polynomial $x^3 - 4x$. $-2, 0$ and 2 are the x -coordinates of the points where the graph of $y = x^3 - 4x$ intersects the X -axis. So this polynomial has three zeroes.



Let us take a few more examples. Consider the cubic polynomials x^3 and $x^3 - x^2$ respectively. See Table 3.4 and 3.5.

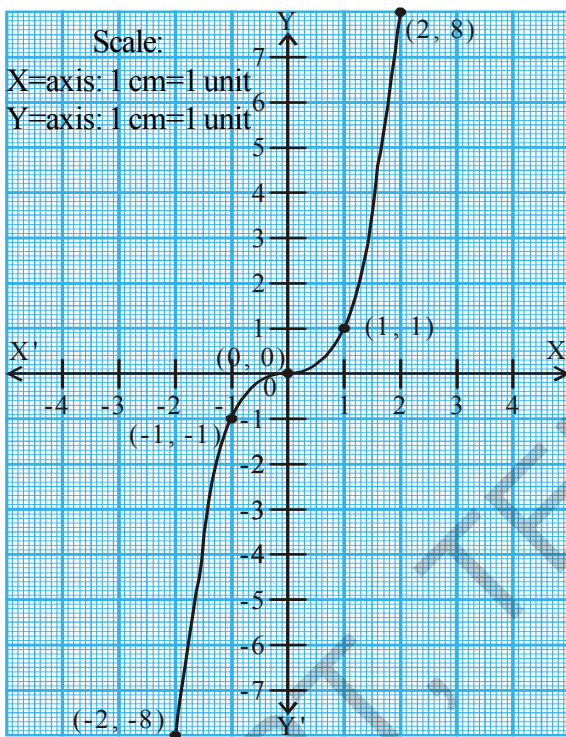
Table 3.4

x	-2	-1	0	1	2
$y = x^3$	-8	-1	0	1	8
(x, y)	$(-2, -8)$	$(-1, -1)$	$(0, 0)$	$(1, 1)$	$(2, 8)$

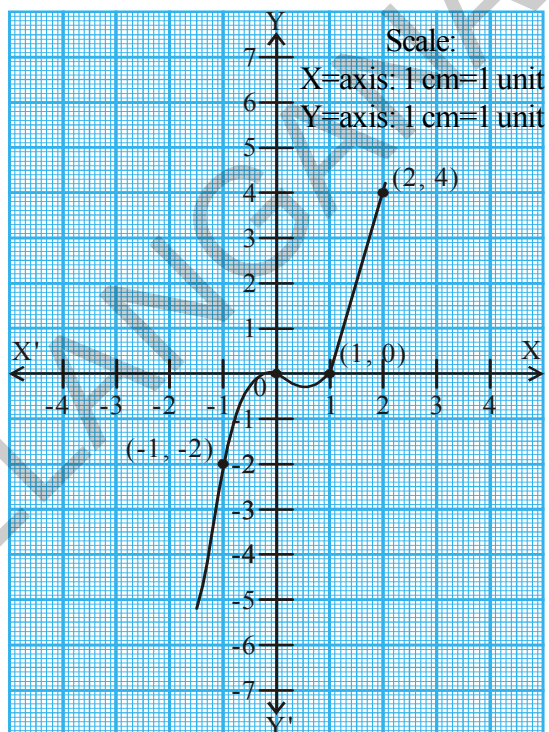


Table 3.5

x	-2	-1	0	1	2
$y = x^3 - x^2$	-12	-2	0	0	4
(x, y)	$(-2, -12)$	$(-1, -2)$	$(0, 0)$	$(1, 0)$	$(2, 4)$



$$y = x^3$$



$$y = x^3 - x^2$$

In $y = x^3$, you can see that 0 (zero) is the x -coordinate of the only point where the graph of $y = x^3$ intersects the X -axis. So, the polynomial has only one zero. Similarly, 0 and 1 are the x -coordinates of the only points where the graph of $y = x^3 - x^2$ intersects the X -axis. So, the cubic polynomial has two distinct zeroes.

From the examples above, we see that there are at most 3 zeroes for any cubic polynomial. In other words, any polynomial of degree 3 can have at most three zeroes.



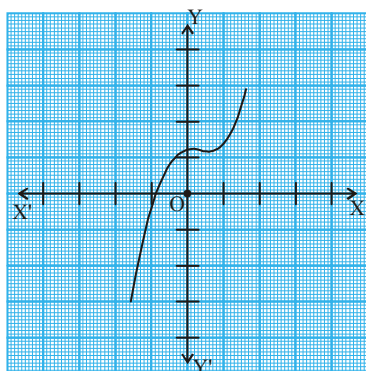
Try This

Find the zeroes of cubic polynomials (i) $-x^3$ (ii) $x^2 - x^3$ (iii) $x^3 - 5x^2 + 6x$ without drawing the graph of the polynomial.

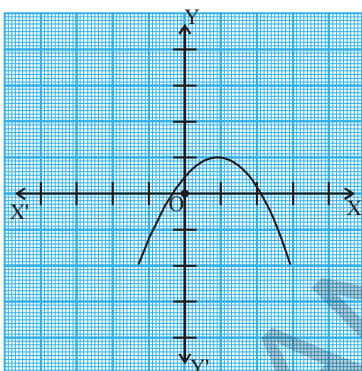


Note : In general, given a polynomial $p(x)$ of degree n , the graph of $y = p(x)$ intersects the X -axis at at most n points. Therefore, a polynomial $p(x)$ of degree n has at most n zeroes. (This is called fundamental theorem of Algebra.

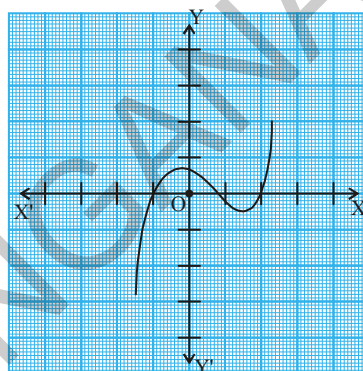
Example-1. Look at the graphs in the figures given below. Each is the graph of $y = p(x)$, where $p(x)$ is a polynomial. In each of the graphs, find the number of zeroes of $p(x)$ in the given range of x .



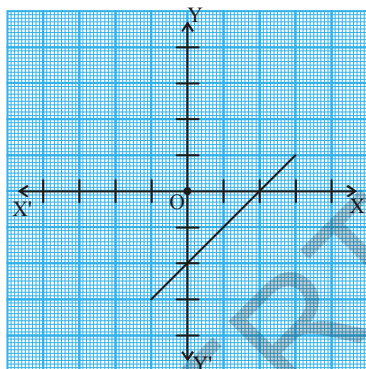
(i)



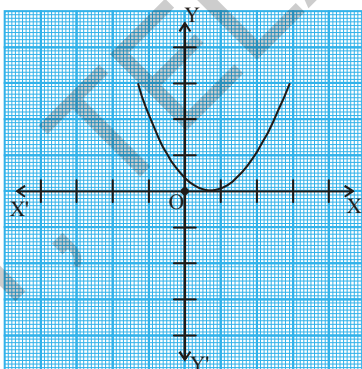
(ii)



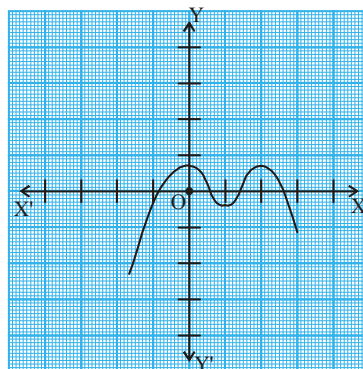
(iii)



(iv)



(v)



(vi)

Solution : In the given range of x in respective graphs :

- (i) The number of zeroes is 1 as the graph intersects the X -axis at one point only.
- (ii) The number of zeroes is 2 as the graph intersects the X -axis at two points.
- (iii) The number of zeroes is 3. (Why?)
- (iv) The number of zeroes is 1. (Why?)
- (v) The number of zeroes is 1. (Why?)
- (vi) The number of zeroes is 4. (Why?)



Example-2. Find the number of zeroes of the given polynomials. And also find their values.

(i) $p(x) = 2x + 1$

(ii) $q(y) = y^2 - 1$

(iii) $r(z) = z^3$

Solution : We will do this without plotting the graph.

(i) $p(x) = 2x + 1$ is a linear polynomial. It has only one zero.

To find zeroes,

$$\text{Let } p(x) = 0$$

$$\text{So, } 2x + 1 = 0$$

$$\text{Therefore } x = \frac{-1}{2}$$

The zero of the given polynomial is $\frac{-1}{2}$.

(ii) $q(y) = y^2 - 1$ is a quadratic polynomial.

It has at most two zeroes.

To find zeroes, let $q(y) = 0$

$$\Rightarrow y^2 - 1 = 0$$

$$\Rightarrow (y + 1)(y - 1) = 0$$

$$\Rightarrow y = -1 \text{ or } y = 1$$

Therefore the zeroes of the polynomial are -1 and 1.

(iii) $r(z) = z^3$ is a cubic polynomial. It has at most three zeroes.

$$\text{Let } r(z) = 0$$

$$\Rightarrow z^3 = 0$$

$$\Rightarrow z = 0$$

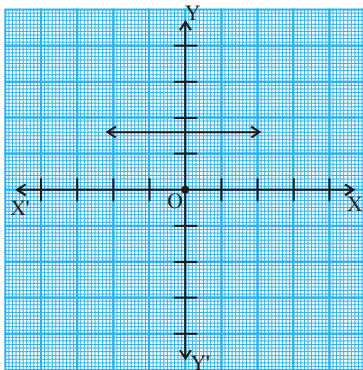
So, the zero of the polynomial is 0.



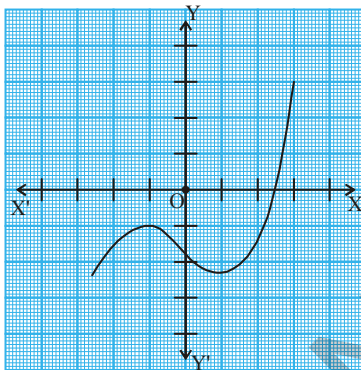


Exercise – 3.2

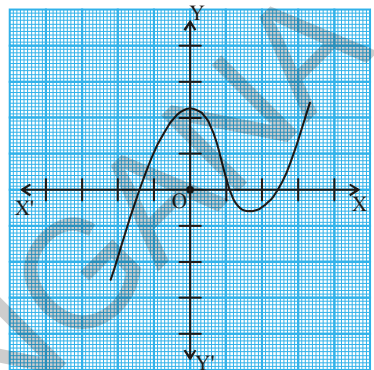
1. The graphs of $y = p(x)$ are given in the figures below, for some polynomials $p(x)$. In each case, find the number of zeroes of $p(x)$.



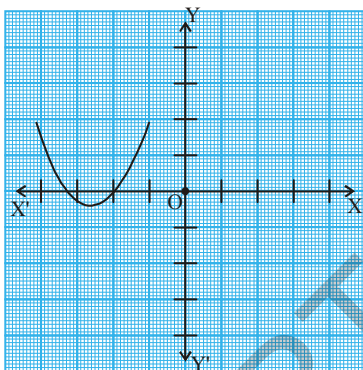
(i)



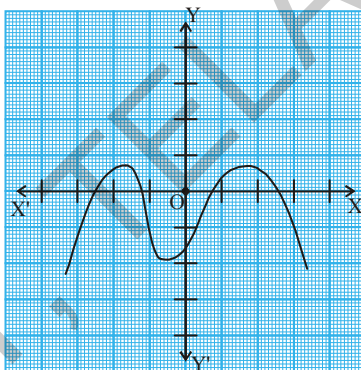
(ii)



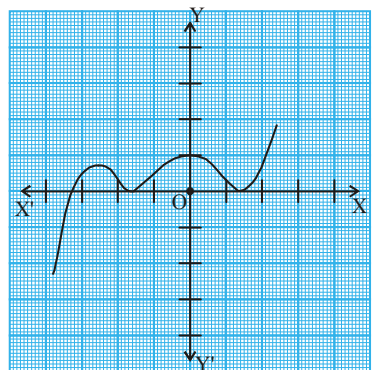
(iii)



(iv)



(v)



(vi)

2. Find the zeroes of the given polynomials.
- (i) $p(x) = 3x$ (ii) $p(x) = x^2 + 5x + 6$
(iii) $p(x) = (x+2)(x+3)$ (iv) $p(x) = x^4 - 16$
3. Draw the graphs of the given polynomial and find the zeroes. Justify the answers.
- (i) $p(x) = x^2 - x - 12$ (ii) $p(x) = x^2 - 6x + 9$
(iii) $p(x) = x^2 - 4x + 5$ (iv) $p(x) = x^2 + 3x - 4$
(v) $p(x) = x^2 - 1$
4. Check whether -1 and $\frac{1}{4}$ are zeroes of the polynomial $p(x) = 4x^2 + 3x - 1$.



3.5 Relationship between Zeroes and Coefficients of a Polynomial

You have already seen that the zero of a linear polynomial $ax + b$ is $-\frac{b}{a}$. Are the zeroes of higher degree polynomials also related to their coefficients? Think about this and discuss with your friends. Now we will try to explore the relationship between zeroes and coefficients of a quadratic polynomial. For this, let us take the quadratic polynomial $p(x) = 2x^2 - 8x + 6$.

In Class-IX, we have learnt how to factorise quadratic polynomials by splitting the middle term. So, we split the middle term ' $-8x$ ' as a sum of two terms, whose product is $6 \times 2x^2 = 12x^2$. So, we write

$$\begin{aligned} 2x^2 - 8x + 6 &= 2x^2 - 6x - 2x + 6 \\ &= 2x(x - 3) - 2(x - 3) \\ &= (2x - 2)(x - 3) = 2(x - 1)(x - 3) \end{aligned}$$

$p(x) = 2x^2 - 8x + 6$ is zero when $x - 1 = 0$ or $x - 3 = 0$, i.e., when $x = 1$ or $x = 3$. So, the zeroes of $2x^2 - 8x + 6$ are 1 and 3. We now try and see if these zeroes have some relationship to the coefficients of terms in the polynomial. The coefficient of x^2 is 2; of x is -8 and the constant is 6, which is the coefficient of x^0 . (i.e. $6x^0 = 6$)

$$\text{We see that the sum of the zeroes} = 1 + 3 = 4 = \frac{-(-8)}{2} = \frac{-(\text{coefficient of } x)}{\text{coefficient of } x^2}$$

$$\text{Product of the zeroes} = 1 \times 3 = 3 = \frac{6}{2} = \frac{\text{constant term}}{\text{coefficient of } x^2}$$

Let us take one more quadratic polynomial: $p(x) = 3x^2 + 5x - 2$.

By splitting the middle term we see,

$$\begin{aligned} 3x^2 + 5x - 2 &= 3x^2 + 6x - x - 2 = 3x(x + 2) - 1(x + 2) \\ &= (3x - 1)(x + 2) \end{aligned}$$

$3x^2 + 5x - 2$ is zero when either $3x - 1 = 0$ or $x + 2 = 0$

i.e., when $x = \frac{1}{3}$ or $x = -2$.

The zeroes of $3x^2 + 5x - 2$ are $\frac{1}{3}$ and -2 . We can see that the :

$$\text{Sum of its zeroes} = \frac{1}{3} + (-2) = \frac{-5}{3} = \frac{-(\text{coefficient of } x)}{\text{coefficient of } x^2}$$

$$\text{Product of its zeroes} = \frac{1}{3} \times (-2) = \frac{-2}{3} = \frac{\text{constant term}}{\text{coefficient of } x^2}$$





Do This

Find the zeroes of the quadratic polynomials given below. Find the sum and product of the zeroes and verify relationship to the coefficients of terms in the polynomial.

(i) $p(x) = x^2 - x - 6$

(ii) $p(x) = x^2 - 4x + 3$

(iii) $p(x) = x^2 - 4$

(iv) $p(x) = x^2 + 2x + 1$

In general, suppose α and β are the zeroes of the quadratic polynomial $p(x) = ax^2 + bx + c$, where $a \neq 0$, then $(x - \alpha)$ and $(x - \beta)$ are the factors of $p(x)$.

Therefore, $ax^2 + bx + c = k(x - \alpha)(x - \beta)$, where k is a constant

$$= k[x^2 - (\alpha + \beta)x + \alpha\beta]$$

$$= kx^2 - k(\alpha + \beta)x + k\alpha\beta$$

Comparing the coefficients of x^2 , x and constant terms on both the sides, we get

$$a = k, b = -k(\alpha + \beta) \text{ and } c = k\alpha\beta.$$

This gives $\alpha + \beta = \frac{-b}{a}$,

$$\alpha\beta = \frac{c}{a}$$

Note : α and β are Greek letters pronounced as ‘alpha’ and ‘beta’ respectively. We will use one more letter ‘ γ ’ pronounced as ‘gamma’.

Sum of zeroes for a quadratic polynomial $ax^2 + bx + c$

$$= \alpha + \beta = \frac{-b}{a} = \frac{-(\text{coefficient of } x)}{\text{coefficient of } x^2}$$

Product of zeroes for a quadratic polynomial $ax^2 + bx + c$

$$= \alpha\beta = \frac{c}{a} = \frac{\text{constant term}}{\text{coefficient of } x^2}$$

Let us consider some examples.

Example-3. Find the zeroes of the quadratic polynomial $x^2 + 7x + 10$ and verify the relationship between the zeroes and the coefficients.

Solution : We have $x^2 + 7x + 10 = (x + 2)(x + 5)$



So, the value of $x^2 + 7x + 10$ is zero when $x + 2 = 0$ or $x + 5 = 0$,

i.e., when $x = -2$ or $x = -5$.

Therefore, the zeroes of $x^2 + 7x + 10$ are -2 and -5 .

$$\text{Now, sum of the zeroes} = -2 + (-5) = -7 = \frac{-(7)}{1} = \frac{-(\text{coefficient of } x)}{\text{coefficient of } x^2}$$

$$\text{Product of the zeroes} = -2 \times (-5) = 10 = \frac{10}{1} = \frac{\text{constant term}}{\text{coefficient of } x^2}$$

Example-4. Find the zeroes of the polynomial $x^2 - 3$ and verify the relationship between the zeroes and the coefficients.

Solution : Recall the identity $a^2 - b^2 = (a - b)(a + b)$.

$$\text{Using it, we can write: } x^2 - 3 = (x - \sqrt{3})(x + \sqrt{3})$$

So, the value of $x^2 - 3$ is zero when $x = \sqrt{3}$ or $x = -\sqrt{3}$.

Therefore, the zeroes of $x^2 - 3$ are $\sqrt{3}$ and $-\sqrt{3}$.

$$\text{Sum of the zeroes} = \sqrt{3} + (-\sqrt{3}) = 0 = \frac{-(\text{coefficient of } x)}{\text{coefficient of } x^2} \quad (\because ax^2 + ox - 3)$$

$$\text{Product of zeroes} = (\sqrt{3}) \times (-\sqrt{3}) = -3 = \frac{-3}{1} = \frac{\text{constant term}}{\text{coefficient of } x^2}$$

Example-5. Find the quadratic polynomial, whose sum and product of the zeroes are -3 and 2 respectively.

Solution : Let the quadratic polynomial be $ax^2 + bx + c$ and its zeroes be α and β . We have

$$\alpha + \beta = -\frac{3}{1} = \frac{-b}{a} \quad \text{and} \quad \alpha\beta = \frac{2}{1} = \frac{c}{a}$$

If we take $a = 1$, then $b = 3$ and $c = 2$

So, one quadratic polynomial which fits the given conditions is $x^2 + 3x + 2$.



Similarly, we can take 'a' to be any real number. Let us say it is k . This gives $\frac{-b}{k} = -3$

or $b = 3k$ and $\frac{c}{k} = 2$ or $c = 2k$. Substituting the values of a , b and c , we get the polynomial is $kx^2 + 3kx + 2k$.

Example-6. Find the quadratic polynomial whose zeroes are 2 and $\frac{-1}{3}$.

Solution : Let the quadratic polynomial be $ax^2 + bx + c$, $a \neq 0$ and its zeroes be α and β .

$$\text{Here } \alpha = 2, \beta = \frac{-1}{3}$$

$$\text{Sum of the zeroes} = (\alpha + \beta) = 2 + \left(\frac{-1}{3}\right) = \frac{5}{3}$$

$$\text{Product of the zeroes} = (\alpha\beta) = 2 \left(\frac{-1}{3}\right) = \frac{-2}{3}$$



Therefore the quadratic polynomial $ax^2 + bx + c$ is

$$k[x^2 - (\alpha + \beta)x + \alpha\beta], \text{ where } k \text{ is a constant and } k \neq 0$$

$$\text{i.e. } k\left[x^2 - \frac{5}{3}x - \frac{2}{3}\right]$$

We can take different values for k .

When $k = 3$, the quadratic polynomial will be $3x^2 - 5x - 2$.

and when $k = 6$, the quadratic polynomial will be $6x^2 - 10x - 4$.



Try This

- (i) Find a quadratic polynomial with zeroes -2 and $\frac{1}{3}$.
- (ii) What is the quadratic polynomial the sum of whose zeroes is $\frac{-3}{2}$ and the product of the zeroes is -1 .



3.6 Cubic Polynomials

Let us now look at cubic polynomials. Do you think similar relation holds between the zeroes of a cubic polynomial and its coefficients as well?

Let us consider $p(x) = 2x^3 - 5x^2 - 14x + 8$.

We see that $p(x) = 0$ for $x = 4, -2, \frac{1}{2}$.

Since $p(x)$ can have at most three zeroes, these are the zeroes of $2x^3 - 5x^2 - 14x + 8$.

$$\text{Sum of its zeroes} = 4 + (-2) + \frac{1}{2} = \frac{5}{2} = \frac{-(-5)}{2} = \frac{-(\text{coefficient of } x^2)}{\text{coefficient of } x^3}$$

$$\text{Product of its zeroes} = 4 \times (-2) \times \frac{1}{2} = -4 = \frac{-8}{2} = \frac{-(\text{constant term})}{\text{coefficient of } x^3}$$

However, there is one more relationship here. Consider the sum of the products of the zeroes taken two at a time. We have:

$$\begin{aligned} &= \{4 \times (-2)\} + \left\{(-2) \times \frac{1}{2}\right\} + \left\{\frac{1}{2} \times 4\right\} \\ &= -8 - 1 + 2 = -7 = \frac{-14}{2} = \frac{\text{constant of } x}{\text{coefficient of } x^3} \end{aligned}$$

In general, it can be proved that if α, β, γ are the zeroes of the cubic polynomial $ax^3 + bx^2 + cx + d$,

$ax^3 + bx^2 + cx + d$ is a polynomial with zeroes α, β, γ .

Let us see how α, β, γ relate to a, b, c, d .

Since α, β, γ are the zeroes, the polynomial can be written as $(x - \alpha)(x - \beta)(x - \gamma)$

$$= x^3 - x^2(\alpha + \beta + \gamma) + x(\alpha\beta + \beta\gamma + \alpha\gamma) - \alpha\beta\gamma$$

To compare with the polynomial, we multiply by a and get

$$ax^3 - x^2a(\alpha + \beta + \gamma) + xa(\alpha\beta + \beta\gamma + \alpha\gamma) - a\alpha\beta\gamma.$$

$$\therefore b = -a(\alpha + \beta + \gamma), c = a(\alpha\beta + \beta\gamma + \alpha\gamma), d = -a\alpha\beta\gamma$$

$$\alpha + \beta + \gamma = \frac{-b}{a}, \quad \alpha\beta + \beta\gamma + \gamma\alpha = \frac{c}{a} \quad \text{and} \quad \alpha\beta\gamma = \frac{-d}{a}.$$





Do This

If α, β, γ are the zeroes of the given cubic polynomials, find the values of the expressions given in the table.

S.No.	Cubic Polynomial	$\alpha + \beta + \gamma$	$\alpha\beta + \beta\gamma + \gamma\alpha$	$\alpha\beta\gamma$
1	$x^3 + 3x^2 - x - 2$			
2	$4x^3 + 8x^2 - 6x - 2$			
3	$x^3 + 4x^2 - 5x - 2$			
4	$x^3 + 5x^2 + 4$			

Let us consider an example.

Example-7. Verify whether 3, -1 and $-\frac{1}{3}$ are the zeroes of the cubic polynomial

$p(x) = 3x^3 - 5x^2 - 11x - 3$, and then verify the relationship between the zeroes and the coefficients.

Solution : $p(x) = 3x^3 - 5x^2 - 11x - 3$ is the given polynomial, by substituting the roots

$$\text{Then } p(3) = 3 \times 3^3 - (5 \times 3^2) - (11 \times 3) - 3 = 81 - 45 - 33 - 3 = 0,$$

$$p(-1) = 3 \times (-1)^3 - 5 \times (-1)^2 - 11 \times (-1) - 3 = -3 - 5 + 11 - 3 = 0,$$

$$p\left(-\frac{1}{3}\right) = 3 \times \left(-\frac{1}{3}\right)^3 - 5 \times \left(-\frac{1}{3}\right)^2 - 11 \times \left(-\frac{1}{3}\right) - 3,$$

$$= -\frac{1}{9} - \frac{5}{9} + \frac{11}{3} - 3 = -\frac{2}{3} + \frac{2}{3} = 0$$

Therefore, 3, -1, and $-\frac{1}{3}$ are the zeroes of $3x^3 - 5x^2 - 11x - 3$.

So, we take $\alpha = 3, \beta = -1$ and $\gamma = -\frac{1}{3}$.

Comparing the given polynomial with $ax^3 + bx^2 + cx + d$, we get

$a = 3, b = -5, c = -11, d = -3$. From this now take $\alpha = 3, \beta = -1, \gamma = -\frac{1}{3}$

$$\alpha + \beta + \gamma = 3 + (-1) + \left(-\frac{1}{3}\right) = 2 - \frac{1}{3} = \frac{5}{3} = \frac{-(-5)}{3} = \frac{-b}{a},$$

$$\alpha\beta + \beta\gamma + \gamma\alpha = 3 \times (-1) + (-1) \times \left(-\frac{1}{3}\right) + \left(-\frac{1}{3}\right) \times 3 = -3 + \frac{1}{3} - 1 = \frac{-11}{3} = \frac{c}{a},$$

$$\alpha\beta\gamma = 3 \times (-1) \times \left(-\frac{1}{3}\right) = 1 = \frac{-(-3)}{3} = \frac{-d}{a}.$$





Exercise – 3.3

- Find the zeroes of the following quadratic polynomials and verify the relationship between the zeroes and the coefficients.
 - $x^2 - 2x - 8$
 - $4s^2 - 4s + 1$
 - $6x^2 - 3 - 7x$
 - $4u^2 + 8u$
 - $t^2 - 15$
 - $3x^2 - x - 4$
- Find the quadratic polynomial in each case with the given numbers as the sum and product of its zeroes respectively.
 - $\frac{1}{4}, -1$
 - $\sqrt{2}, \frac{1}{3}$
 - $0, \sqrt{5}$
 - $1, 1$
 - $-\frac{1}{4}, \frac{1}{4}$
 - $4, 1$
- Find the quadratic polynomial for the zeroes α, β given in each case.
 - $2, -1$
 - $\sqrt{3}, -\sqrt{3}$
 - $\frac{1}{4}, -1$
 - $\frac{1}{2}, \frac{3}{2}$
- Verify that 1, -1 and +3 are the zeroes of the cubic polynomial $x^3 - 3x^2 - x + 3$ and check the relationship between zeroes and the coefficients.

3.7 Division Algorithm for Polynomials

You know that a cubic polynomial has at most three zeroes. However, if you are given only one zero, can you find the other two? For example, let us consider the cubic polynomial $x^3 + 3x^2 - x - 3$. If one of its zeroes is 1, then you know that this polynomial is divisible by $x - 1$. Therefore, we would get the quotient $x^2 - 2x - 3$ on dividing by $x - 1$.

We get the factors of $x^2 - 2x - 3$ by splitting the middle term. The factors are $(x + 1)$ and $(x - 3)$. This gives us

$$\begin{aligned}x^3 - 3x^2 - x + 3 &= (x - 1)(x^2 - 2x - 3) \\ &= (x - 1)(x + 1)(x - 3)\end{aligned}$$

So, the three zeroes of the cubic polynomial are 1, -1, 3.

Let us discuss the method of dividing one polynomial by another in detail. Before doing the steps formally, consider an example.



Example-8. Divide $2x^2 + 3x + 1$ by $x + 2$.

Solution : Note that we stop the division process when either the remainder is zero or its degree is less than the degree of the divisor. So, here the quotient is $2x - 1$ and the remainder is 3.

$$\begin{array}{r} 2x-1 \\ x+2 \overline{) 2x^2+3x+1} \\ \underline{2x^2+4x} \\ -x+1 \\ \underline{-x-2} \\ + \\ 3 \end{array}$$

Let us verify division algorithm.

$$(2x - 1)(x + 2) + 3 = 2x^2 + 3x - 2 + 3 = 2x^2 + 3x + 1$$

$$\text{i.e., } 2x^2 + 3x + 1 = (x + 2)(2x - 1) + 3$$

Therefore, Dividend = Divisor \times Quotient + Remainder

Let us now extend this process to divide a polynomial by a quadratic polynomial.

Example-9. Divide $3x^3 + x^2 + 2x + 5$ by $1 + 2x + x^2$.

Solution : We first arrange the terms of the dividend and the divisor in the decreasing order of their exponents. (Arranging the terms in this order is termed as writing the polynomials in its standard form). In this example, the dividend is already in its standard form and the divisor in standard form, is $x^2 + 2x + 1$.

$$\begin{array}{r} 3x-5 \\ x^2+2x+1 \overline{) 3x^3+x^2+2x+5} \\ \underline{3x^3+6x^2+3x} \\ -5x^2-x+5 \\ \underline{-5x^2-10x-5} \\ + \\ 9x+10 \end{array}$$

Step 1 : To obtain the first term of the quotient, divide the highest degree term of the dividend (i.e., $3x^3$) by the highest degree term of the divisor (i.e., x^2). This is $3x$.

Then carry out the division process. What remains is $-5x^2 - x + 5$.

Step 2 : Now, to obtain the second term of the quotient, divide the highest degree term of the new dividend (i.e., $-5x^2$) by the highest degree term of the divisor (i.e., x^2). This gives -5 . Continue the division with $-5x^2 - x + 5$

Step 3 : What remains is $9x + 10$. Now, the degree of $9x + 10$ is less than the degree of the divisor $x^2 + 2x + 1$. So, we cannot continue the division any further. Why?

So, the quotient is $3x - 5$ and the remainder is $9x + 10$. Also,

$$\begin{aligned} (x^2 + 2x + 1) \times (3x - 5) + (9x + 10) &= (3x^3 + 6x^2 + 3x - 5x^2 - 10x - 5 + 9x + 10) \\ &= 3x^3 + x^2 + 2x + 5 \end{aligned}$$

Here, again we see that

$$\text{Dividend} = \text{Divisor} \times \text{Quotient} + \text{Remainder}$$



We are applying here an algorithm called division algorithm.

This says that

If $p(x)$ and $g(x)$ are any two polynomials with $g(x) \neq 0$, then we can find polynomials $q(x)$ and $r(x)$ such that

We can write $p(x) = g(x) \times q(x) + r(x)$,

where either $r(x) = 0$ or degree of $r(x) <$ degree of $g(x)$ if $r(x) \neq 0$

This result is known as the **Division Algorithm** for polynomials.

Now, we have the following results from the above discussions

- (i) If $g(x)$ is a linear polynomial, then $r(x) = r$ is a constant.
- (ii) If degree of $g(x) = 1$, then degree of $p(x) = 1 +$ degree of $q(x)$.
- (iii) If $p(x)$ is divided by $(x - a)$, then the remainder is $p(a)$.
- (iv) If $r = 0$, we say $q(x)$ divides $p(x)$ exactly or $q(x)$ is a factor of $p(x)$.

Let us now take some examples to illustrate its use.

Example-10. Divide $3x^2 - x^3 - 3x + 5$ by $x - 1 - x^2$, and verify the division algorithm.

Solution : Note that the given polynomials are not in standard form. To carry out division, we first write both the dividend and divisor in decreasing orders of their degrees.

So, dividend = $-x^3 + 3x^2 - 3x + 5$ and

divisor = $-x^2 + x - 1$.

Division process is shown on the right side.

We stop here since degree of the remainder is less than the degree of the divisor i.e. $(-x^2 + x - 1)$.

So, quotient = $x - 2$, remainder = 3.

Now,

Dividend = Divisor \times Quotient + Remainder

$$\begin{aligned} &= (-x^2 + x - 1)(x - 2) + 3 \\ &= -x^3 + x^2 - x + 2x^2 - 2x + 2 + 3 \\ &= -x^3 + 3x^2 - 3x + 5 \end{aligned}$$

In this way, the division algorithm is verified.

$$\begin{array}{r} x-2 \\ -x^2+x-1 \overline{) -x^3+3x^2-3x+5} \\ \underline{-x^3+x^2-x} \\ 2x^2-2x+5 \\ \underline{2x^2-2x+2} \\ 3 \end{array}$$



Example-11. Find all the remaining zeroes of $2x^4 - 3x^3 - 3x^2 + 6x - 2$, if you know that two of its zeroes are $\sqrt{2}$ and $-\sqrt{2}$.

Solution : Since two of the zeroes are $\sqrt{2}$ and $-\sqrt{2}$, therefore we can divide by

$$(x - \sqrt{2})(x + \sqrt{2}) = x^2 - 2.$$

$$\begin{array}{r}
 2x^2 - 3x + 1 \\
 x^2 + 0x - 2 \overline{) 2x^4 - 3x^3 - 3x^2 + 6x - 2} \\
 \underline{2x^4 + 0x^3 - 4x^2} \\
 -3x^3 + x^2 + 6x - 2 \\
 \underline{-3x^3 + 0x^2 + 6x} \\
 + - \\
 x^2 + 0x - 2 \\
 x^2 + 0x - 2 \\
 \underline{ - } \\
 0
 \end{array}$$

First term of quotient is $\frac{2x^4}{x^2} = 2x^2$

Second term of quotient is $\frac{-3x^3}{x^2} = -3x$

Third term of quotient is $\frac{x^2}{x^2} = 1$

So, $2x^4 - 3x^3 - 3x^2 + 6x - 2 = (x^2 - 2)(2x^2 - 3x + 1)$.

Now, by splitting $-3x$, we factorize $2x^2 - 3x + 1$ as $(2x - 1)(x - 1)$. So, its zeroes are given by $x = \frac{1}{2}$ and $x = 1$.

Therefore, the zeroes of the given polynomial are $\sqrt{2}, -\sqrt{2}, 1$ and $\frac{1}{2}$.



Exercise – 3.4

1. Divide the polynomial $p(x)$ by the polynomial $g(x)$ and find the quotient and the remainder in each of the following :
 - (i) $p(x) = x^3 - 3x^2 + 5x - 3, g(x) = x^2 - 2$
 - (ii) $p(x) = x^4 - 3x^2 + 4x + 5, g(x) = x^2 + 1 - x$
 - (iii) $p(x) = x^4 - 5x + 6, g(x) = 2 - x^2$



2. Check in which case the first polynomial is a factor of the second polynomial by dividing the second polynomial by the first polynomial :
- (i) $t^2 - 3, 2t^4 + 3t^3 - 2t^2 - 9t - 12$
- (ii) $x^2 + 3x + 1, 3x^4 + 5x^3 - 7x^2 + 2x + 2$
- (iii) $x^3 - 3x + 1, x^5 - 4x^3 + x^2 + 3x + 1$
3. Obtain all other zeroes of $3x^4 + 6x^3 - 2x^2 - 10x - 5$, if two of its zeroes are $\sqrt{\frac{5}{3}}$ and $-\sqrt{\frac{5}{3}}$.
4. On dividing $x^3 - 3x^2 + x + 2$ by a polynomial $g(x)$, the quotient and remainder were $x - 2$ and $-2x + 4$, respectively. Find $g(x)$.
5. Give examples of polynomials $p(x), g(x), q(x)$ and $r(x)$, which satisfy the division algorithm and
- (i) degree $p(x) = \text{degree } q(x)$ (ii) degree $q(x) = \text{degree } r(x)$ (iii) degree $r(x) = 0$



Optional Exercise
[For extensive learning]

1. Verify that the numbers given alongside the cubic polynomials below are their zeroes. Also verify the relationship between the zeroes and the coefficients in each case:
- (i) $2x^3 + x^2 - 5x + 2$; $(\frac{1}{2}, 1, -2)$ (ii) $x^3 - 4x^2 + 5x - 2$ (1, 1, 1)
2. Find a cubic polynomial with the sum, sum of the product of its zeroes taken two at a time, and the product of its zeroes as 2, -7, -14 respectively.
3. If the zeroes of the polynomial $x^3 - 3x^2 + x + 1$ are $a - b, a, a + b$ find a and b .
4. If two zeroes of the polynomial $x^4 - 6x^3 - 26x^2 + 138x - 35$ are $2 \pm \sqrt{3}$, find the other zeroes.
5. If the polynomial $x^4 - 6x^3 - 16x^2 + 25x + 10$ is divided by another polynomial $x^2 - 2x + k$, the remainder comes out to be $x + a$, find k and a .



Suggested Projects

Quadratic polynomial - Zeroes of the polynomial - geometrical meaning/ graphs.

- Draw graphs for quadratic polynomial $ax^2 + bx + c$ for various conditions.
(i) $a > 0$ (ii) $a < 0$ (iii) $a = 0$ (iv) $b > 0$ (v) $b < 0$
(vi) $b = 0$ and comment on the graphs



What We Have Discussed



1. Polynomials of degrees 1, 2 and 3 are called linear, quadratic and cubic polynomials respectively.
2. A quadratic polynomial in x with real coefficients is of the form $ax^2 + bx + c$, where a, b, c are real numbers with $a \neq 0$.
3. The zeroes of a polynomial $p(x)$ are the x -coordinates of the points where the graph of $y = p(x)$ intersects the X -axis.
4. A quadratic polynomial can have at most 2 zeroes and a cubic polynomial can have at most 3 zeroes.
5. If α and β are the zeroes of the quadratic polynomial $ax^2 + bx + c, a \neq 0$, then
$$\alpha + \beta = -\frac{b}{a}, \quad \alpha\beta = \frac{c}{a}.$$
6. If α, β, γ are the zeroes of the cubic polynomial $ax^3 + bx^2 + cx + d, a \neq 0$, then
$$\alpha + \beta + \gamma = -\frac{b}{a},$$
$$\alpha\beta + \beta\gamma + \gamma\alpha = \frac{c}{a},$$
and
$$\alpha\beta\gamma = \frac{-d}{a}.$$
7. The division algorithm states that given any polynomial $p(x)$ and any non-zero polynomial $g(x)$, there exist polynomials $q(x)$ and $r(x)$ such that
$$p(x) = g(x) q(x) + r(x),$$
where either $r(x) = 0$ or $\text{degree } r(x) < \text{degree } g(x)$ if $r(x) \neq 0$.





4.1 Introduction

One day, Siri went to a book shop with her father and bought 3 notebooks and 2 pens. Her father paid ₹80 for them. Her friend Laxmi liked the notebooks and pens. So, she too bought 4 notebooks and 3 pens of the same kind for ₹110. Now her classmates Rubina liked the pens whereas Joseph liked the notebooks. They asked Siri the cost of the pen and the notebook separately. But, Siri did not know the costs separately. How will they find the costs of these items?

In this example, the cost of a notebook and a pen are not known. These are unknown quantities. We come across many such situations in our day-to-day life.



Think & Discuss

Two situations are given below:

- (i) The cost of 1kg potatoes and 2kg tomatoes was ₹30 on a certain day. After two days, the cost of 2kg potatoes and 4kg tomatoes was found to be ₹66.
- (ii) The coach of a cricket team of M.K.Nagar High School buys 3 bats and 6 balls for ₹3900. Later he buys one more bat and 2 balls for ₹1300.

Identify the unknowns in each situation. We observe that there are two unknowns in each case.

4.1.1 How Do We Find Unknown Quantities?

In the introduction, Siri bought 3 notebooks and 2 pens for ₹80. How can we find the cost of a notebook or the cost of a pen?

Rubina and Joseph tried to guess. Rubina said that price of each notebook could be ₹25. Then three notebooks would cost ₹75 and the two pens would cost ₹5. In that case each pen could be for ₹2.50. Joseph felt that ₹2.50 for one pen was too less. In his opinion, it should be at least ₹16. Then the price of each notebook would also be ₹16.

We can see that there can be many possible values for the price of a notebook and of a pen so that the total cost is ₹80. So, how do we find the price at which Siri and Laxmi bought them? By using only Siri's situation, we cannot find the costs. We have to use Laxmi's situation also.



4.1.2 Using Both Equations Together

Laxmi also bought the same types of notebooks and pens as Siri. She paid ₹110 for 4 notebooks and 3 pens.

So, we have two situations which can be represented as follows:

- (i) Cost of 3 notebooks + 2 pens = ₹80.
- (ii) Cost of 4 notebooks + 3 pens = ₹110.

Does this help us find the cost of a pen and a notebook?

Consider the prices mentioned by Rubina. If the price of one notebook is ₹25 and the price of one pen is ₹2.50 then,

The cost of 4 notebooks would be : $4 \times 25 = ₹100$

And the cost for 3 pens would be : $3 \times 2.50 = ₹7.50$

If Rubina is right then Laxmi should have paid ₹100 + ₹7.50 = ₹107.50 but she paid ₹110.

Now, consider the prices mentioned by Joseph.

The cost of 4 notebooks, if one is for ₹16, would be : $4 \times 16 = ₹64$

And the cost for 3 pens, if one is for ₹16, would be : $3 \times 16 = ₹48$

If Joseph is right then Laxmi should have paid ₹64 + ₹48 = ₹112 but this is more than the price she paid.

So what do we do? How to find the exact cost of the notebook and the pen?

If we have only one equation but two unknowns (variables), we can find many solutions. So, when we have two variables, we need at least two independent equations to get a unique solution. One way to find the values of unknown quantities is by using the Model method. In this method, rectangles or portions of rectangles are often used to represent the unknowns. Let us look at the first situation using the model method:

Step-1 : Represent a notebook by  and a pen by .

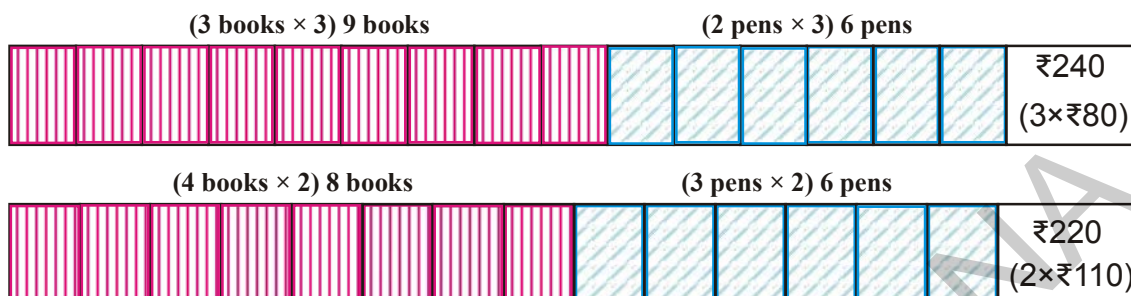
Siri bought 3 books and 2 pens for ₹80.



Laxmi bought 4 books and 3 pens for ₹110.



Step-2 : Increase (or decrease) the quantities in proportion to make one of the quantities equal in both situations. Here, we make the number of pens equal.



In Step 2, we observe a simple proportional reasoning.

Since, Siri bought 3 books and 2 pens for ₹80, so for 9 books and 6 pens:

$$3 \times 3 = 9 \text{ books and } 3 \times 2 = 6 \text{ pens, the cost will be } 3 \times 80 = \text{₹}240 \quad (1)$$

Similarly, Laxmi bought 4 books and 3 pens for ₹110, so:

$$2 \times 4 = 8 \text{ books and } 2 \times 3 = 6 \text{ pens will cost } 2 \times 110 = \text{₹}220 \quad (2)$$

After comparing (1) and (2), we can easily observe that 1 extra book costs

$$\text{₹}240 - \text{₹}220 = \text{₹}20. \text{ So one book cost is } \text{₹}20.$$

Siri bought 3 books and 2 pens for ₹80. Since each book costs ₹20, 3 books cost ₹60. So the cost of 2 pens become ₹80 – ₹60 = ₹20.

$$\text{So, cost of each pen is } \text{₹}20 \div 2 = \text{₹}10.$$

Let us try these costs in Laxmi's situation. 4 books will cost ₹80 and three pens will cost ₹30 for a total of ₹110, which is true.

From the above discussion and calculation, it is clear that to get exactly one solution (unique solution) we need at least two independent linear equations in the same two variables.

In general, an equation of the form $ax + by + c = 0$, where a, b, c are real numbers and where at least one of a or b is not zero i.e. $a^2 + b^2 \neq 0$, is called a linear equation in two variables x and y .



Try This

Mark the correct option in the following questions:

- Which of the following equations is not a linear equation?

a) $5 + 4x = y + 3$	b) $x + 2y = y - x$
c) $3 - x = y^2 + 4$	d) $x + y = 0$



2. Which of the following is a linear equation in one variable?

a) $2x + 1 = y - 3$	b) $2t - 1 = 2t + 5$
c) $2x - 1 = x^2$	d) $x^2 - x + 1 = 0$
3. Which of the following numbers is a solution for the equation $2(x + 3) = 18$?

a) 5	b) 6	c) 13	d) 21
------	------	-------	-------
4. The value of x which satisfies the equation $2x - (4 - x) = 5 - x$ is

a) 4.5	b) 3	c) 2.25	d) 0.5
--------	------	---------	--------
5. The equation $x - 4y = 5$ has

a) no solution	b) unique solution
c) two solutions	d) infinitely many solutions

4.2 Solutions of Pairs of Linear Equations in Two Variables

In the introductory example of notebooks and pens, how many equations did we have? We had two equations or a pair of linear equations in two variables. What do we mean by the solution for a pair of linear equations?

A pair of values of the variables x and y which together satisfy each one of the equations is called a solution for a pair of linear equations.

4.2.1 Graphical Method of Finding Solution of a Pair of Linear Equations

What will be the number of solutions for a pair of linear equations in two variables? Is the number of solutions infinite or unique or none?

In an earlier section, we used the model method for solving the pair of linear equations. Now, we will use graphs to solve the equations.

Let: $a_1x + b_1y + c_1 = 0$, ($a_1^2 + b_1^2 \neq 0$) and $a_2x + b_2y + c_2 = 0$; ($a_2^2 + b_2^2 \neq 0$) form a pair of linear equation in two variables.

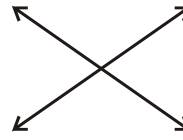
The graph of a linear equation in two variables is a straight line. Ordered pairs of real numbers (x, y) representing points on the line are solutions of the equation and ordered pairs of real numbers (x, y) that do not represent points on the line are not solutions.

If we have two lines in the same plane, what can be the possible relations between them? What is the significance of this relation?



When two lines are drawn in the same plane, only one of the following three situations is possible:

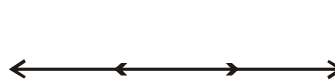
i) The two lines may intersect at one point.



ii) The two lines may not intersect i.e., they are parallel.



iii) The two lines may be coincident.
(actually both are same)



Let us write the equations in the first example in terms of x and y , where x is the cost of a notebook and y is the cost of a pen. Then, the equations are $3x + 2y = 80$ and $4x + 3y = 110$.

For the equation $3x + 2y = 80$		
x	$y = \frac{80 - 3x}{2}$	(x, y)
0	$y = \frac{80 - 3(0)}{2} = 40$	(0, 40)
10	$y = \frac{80 - 3(10)}{2} = 25$	(10, 25)
20	$y = \frac{80 - 3(20)}{2} = 10$	(20, 10)
30	$y = \frac{80 - 3(30)}{2} = -5$	(30, -5)

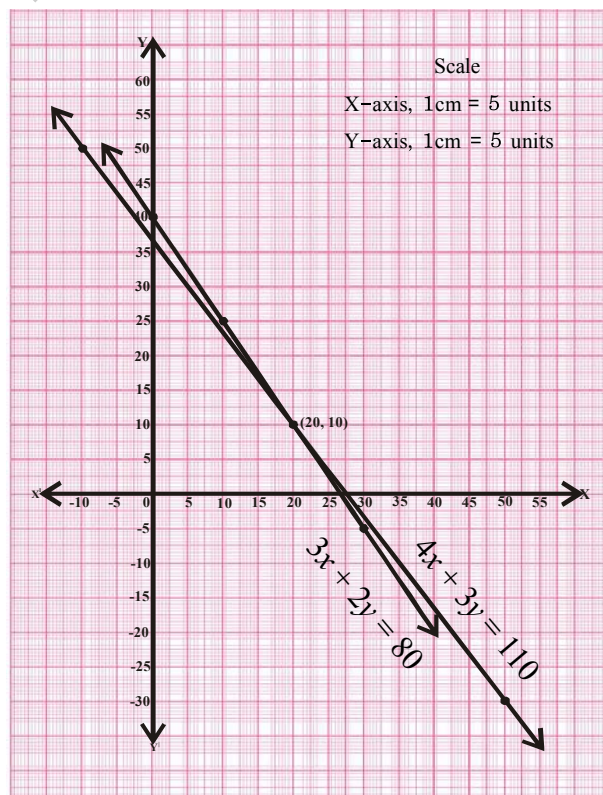
For the equation $4x + 3y = 110$		
x	$y = \frac{110 - 4x}{3}$	(x, y)
-10	$y = \frac{110 - 4(-10)}{3} = 50$	(-10, 50)
20	$y = \frac{110 - 4(20)}{3} = 10$	(20, 10)
50	$y = \frac{110 - 4(50)}{3} = -30$	(50, -30)

After plotting the above points in the Cartesian plane, we observe that the two straight lines are intersecting at the point (20, 10).

Substituting the values of x and y in the equations, we get $3(20) + 2(10) = 80$ and $4(20) + 3(10) = 110$. Thus both the equations are satisfied.

Thus, as determined by the graphical method, the cost of each book is ₹20 and of each pen is ₹10. Recall that we got the same solution using the model method.

Since (20, 10) is the common point, there is only one solution for this pair of linear equations in two variables. Such equations are known as **consistent** and **independent** pair of linear equations. They will always have a unique solution.

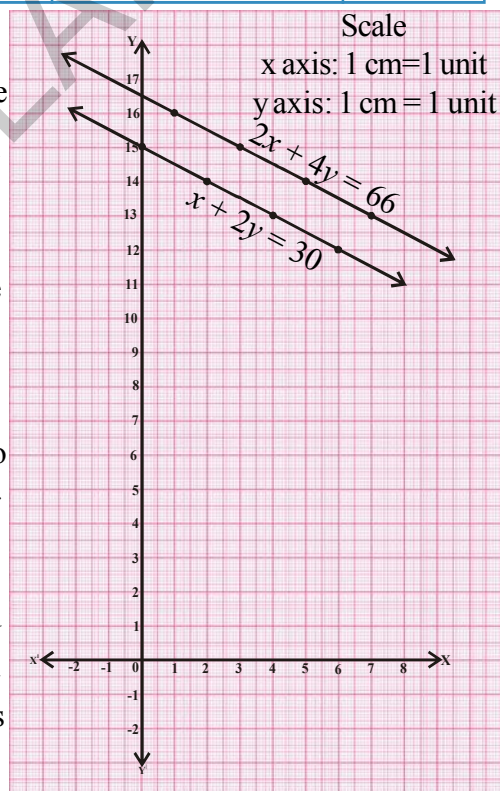


Now, let us look at the first example from the ‘think and discuss section’. We want to find the cost of 1kg of potatoes and the cost of 1 kg of tomatoes each. Let the cost of 1kg potatoes be ₹ x and cost of 1kg of tomatoes be ₹ y . Then, the equations will become $1x+2y=30$ and $2x+4y=66$.

For the equation $x + 2y = 30$		
x	$y = \frac{30-x}{2}$	(x, y)
0	$y = \frac{30-0}{2} = 15$	(0, 15)
2	$y = \frac{30-2}{2} = 14$	(2, 14)
4	$y = \frac{30-4}{2} = 13$	(4, 13)
6	$y = \frac{30-6}{2} = 12$	(6, 12)

For the equation $2x + 4y = 66$		
x	$y = \frac{66-2x}{4}$	(x, y)
1	$y = \frac{66-2(1)}{4} = 16$	(1, 16)
3	$y = \frac{66-2(3)}{4} = 15$	(3, 15)
5	$y = \frac{66-2(5)}{4} = 14$	(5, 14)
7	$y = \frac{66-2(7)}{4} = 13$	(7, 13)

Here, we observe that the situation is represented graphically by two parallel lines. Since the lines do not intersect, the equations have no common solution. This means that the cost of the potato and tomato was different on different days. We see this in real life also. We cannot expect the same price of vegetables every day; it keeps changing. Also, the change is independent.



Such pairs of linear equations which have no solution are known as **inconsistent** pairs of linear equations.

In the second example, from the “think and discuss” section, let the cost of each bat be ₹ x and each ball be ₹ y . Then we can write the equations as $3x + 6y = 3900$ and $x + 2y = 1300$.

For the equation $3x + 6y = 3900$		
x	$y = \frac{3900-3x}{6}$	(x, y)
100	$y = \frac{3900-3(100)}{6} = 600$	(100, 600)

For the equation $x + 2y = 1300$		
x	$y = \frac{1300-x}{2}$	(x, y)
100	$y = \frac{1300-100}{2} = 600$	(100, 600)

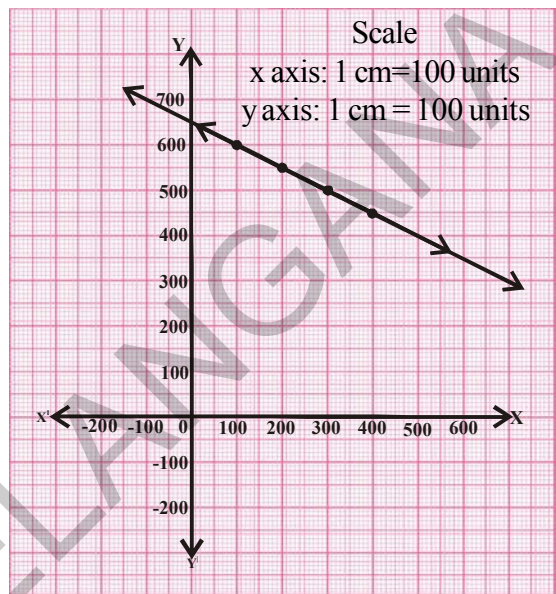


200	$y = \frac{3900 - 3(200)}{6} = 550$	(200, 550)
300	$y = \frac{3900 - 3(300)}{6} = 500$	(300, 500)
400	$y = \frac{3900 - 3(400)}{6} = 450$	(400, 450)

200	$y = \frac{1300 - 200}{2} = 550$	(200, 550)
300	$y = \frac{1300 - 300}{2} = 500$	(300, 500)
400	$y = \frac{1300 - 400}{2} = 450$	(400, 450)

The equations are geometrically shown by a pair of coincident lines. If the solutions of the equations are given by the common points, then what are the common points in this case?

From the graph, we observe that every point on the line is a common solution to both the equations. So, they have infinitely many solutions as both the equations are equivalent. Such pairs of equations are called **consistent** and **dependent** pair of linear equations in two variables. This system of equations that has solution are known as '**consistent equations**'.



Try this

In the example given above, can you find the cost of each bat and ball?



Think & discuss

Is a dependent pair of linear equations always consistent. Why or why not?



Do this

- Represent the following systems of equations graphically and comment on solutions:
 - $x - 2y = 0$
 $3x + 4y = 20$
 - $x + y = 2$
 $2x + 2y = 4$
 - $2x - y = 4$
 $4x - 2y = 6$
- Represent the pair of linear equations $x + 2y - 4 = 0$ and $2x + 4y - 12 = 0$ graphically and comment on solutions.

4.2.3 Relation Between Coefficients and Nature of System of Equations

Let a_1, b_1, c_1 and a_2, b_2, c_2 denote the coefficients of a given pair of linear equations in two variables. Then, let us write and compare the values of $\frac{a_1}{a_2}$, $\frac{b_1}{b_2}$ and $\frac{c_1}{c_2}$ in the above examples.



Pair of lines	$\frac{a_1}{a_2}$	$\frac{b_1}{b_2}$	$\frac{c_1}{c_2}$	Comparison of ratios	Algebraic interpretation	Graphical representation	Solutions
1. $3x+2y-80=0$ $4x+3y-110=0$	$\frac{3}{4}$	$\frac{2}{3}$	$\frac{-80}{-110}$	$\frac{a_1}{a_2} \neq \frac{b_1}{b_2}$	Consistent and Independent	Intersecting	One solution
2. $1x+2y-30=0$ $2x+4y-66=0$	$\frac{1}{2}$	$\frac{2}{4}$	$\frac{-30}{-66}$	$\frac{a_1}{a_2} = \frac{b_1}{b_2} \neq \frac{c_1}{c_2}$	Inconsistent	Parallel	No solution
3. $3x+6y=3900=0$ $x+2y=1300=0$	$\frac{3}{1}$	$\frac{6}{2}$	$\frac{3900}{1300}$	$\frac{a_1}{a_2} = \frac{b_1}{b_2} = \frac{c_1}{c_2}$	Consistent and dependent	Coincident	Infinitely many solutions

Let us look at examples.

Example-1. Check whether the given pair of equations represent intersecting or parallel or coincident lines. Find the solution if the lines are intersecting.

$$2x + y - 5 = 0$$

$$3x - 2y - 4 = 0$$

Solution : $\frac{a_1}{a_2} = \frac{2}{3}$ $\frac{b_1}{b_2} = \frac{1}{-2}$ $\frac{c_1}{c_2} = \frac{-5}{-4}$

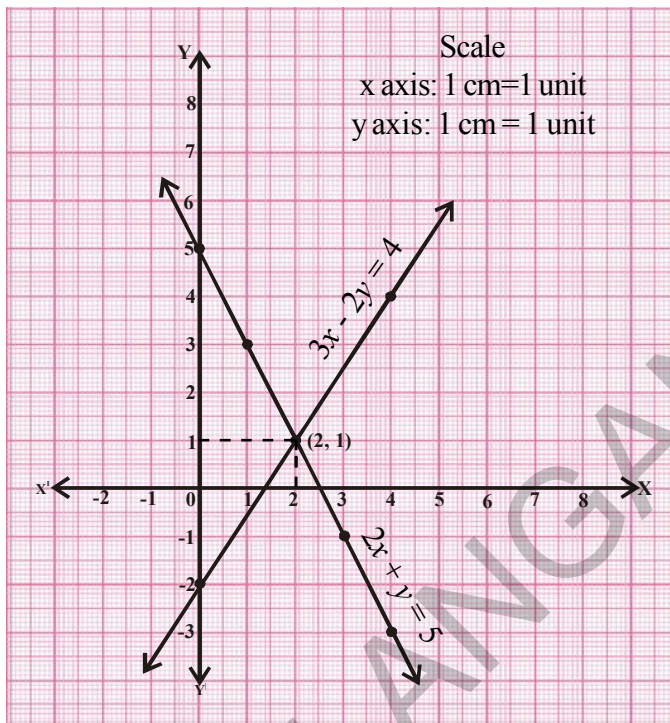
Since $\frac{a_1}{a_2} \neq \frac{b_1}{b_2}$, therefore they are intersecting lines and hence, it is a consistent pair of linear equation.

For the equation $2x + y = 5$		
x	$y = 5 - 2x$	(x, y)
0	$y = 5 - 2(0) = 5$	$(0, 5)$
1	$y = 5 - 2(1) = 3$	$(1, 3)$
2	$y = 5 - 2(2) = 1$	$(2, 1)$
3	$y = 5 - 2(3) = -1$	$(3, -1)$
4	$y = 5 - 2(4) = -3$	$(4, -3)$

For the equation $3x - 2y = 4$		
x	$y = \frac{4-3x}{-2}$	(x, y)
0	$y = \frac{4-3(0)}{-2} = -2$	$(0, -2)$
2	$y = \frac{4-3(2)}{-2} = 1$	$(2, 1)$
4	$y = \frac{4-3(4)}{-2} = 4$	$(4, 4)$



The unique solution of this pair of equations is (2,1).



Example-2. Check whether the following pair of equations is consistent.

$3x + 4y = 2$ and $6x + 8y = 4$. Verify by a graphical representation.

Solution : $3x + 4y - 2 = 0$

$$6x + 8y - 4 = 0$$

$$\frac{a_1}{a_2} = \frac{3}{6} = \frac{1}{2}$$

$$\frac{b_1}{b_2} = \frac{4}{8} = \frac{1}{2}$$

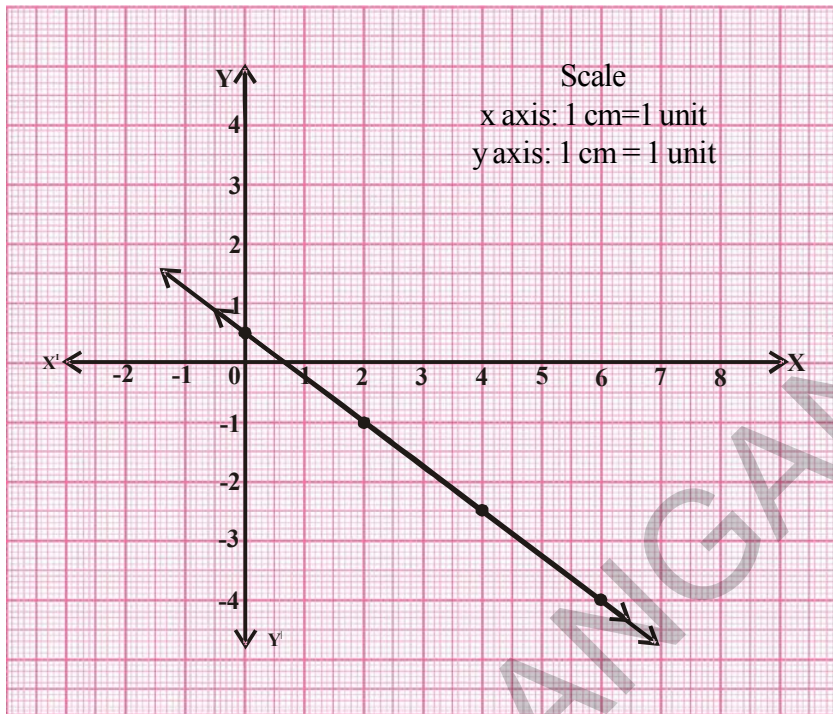
$$\frac{c_1}{c_2} = \frac{-2}{-4} = \frac{1}{2}$$

Since $\frac{a_1}{a_2} = \frac{b_1}{b_2} = \frac{c_1}{c_2}$, therefore, they are coincident lines. So, the pair of linear equations are consistent and dependent and have infinitely many solutions.

For the equation $3x + 4y = 2$		
x	$y = \frac{2 - 3x}{4}$	(x, y)
0	$y = \frac{2 - 3(0)}{4} = \frac{1}{2}$	$(0, \frac{1}{2})$
2	$y = \frac{2 - 3(2)}{4} = -1$	$(2, -1)$
4	$y = \frac{2 - 3(4)}{4} = -2.5$	$(4, -2.5)$
6	$y = \frac{2 - 3(6)}{4} = -4$	$(6, -4)$

For the equation $6x + 8y = 4$		
x	$y = \frac{4 - 6x}{8}$	(x, y)
0	$y = \frac{4 - 6(0)}{8} = \frac{1}{2}$	$(0, \frac{1}{2})$
2	$y = \frac{4 - 6(2)}{8} = -1$	$(2, -1)$
4	$y = \frac{4 - 6(4)}{8} = -2.5$	$(4, -2.5)$
6	$y = \frac{4 - 6(6)}{8} = -4$	$(6, -4)$





Example-3. Check whether the system of equations $2x-3y=5$ and $4x-6y=15$ are consistent. Also verify by graphical representation.

Solution : $4x-6y-15=0$

$$2x-3y-5=0$$

$$\frac{a_1}{a_2} = \frac{4}{2} = \frac{2}{1}$$

$$\frac{b_1}{b_2} = \frac{-6}{-3} = \frac{2}{1}$$

$$\frac{c_1}{c_2} = \frac{-15}{-5} = \frac{3}{1}$$

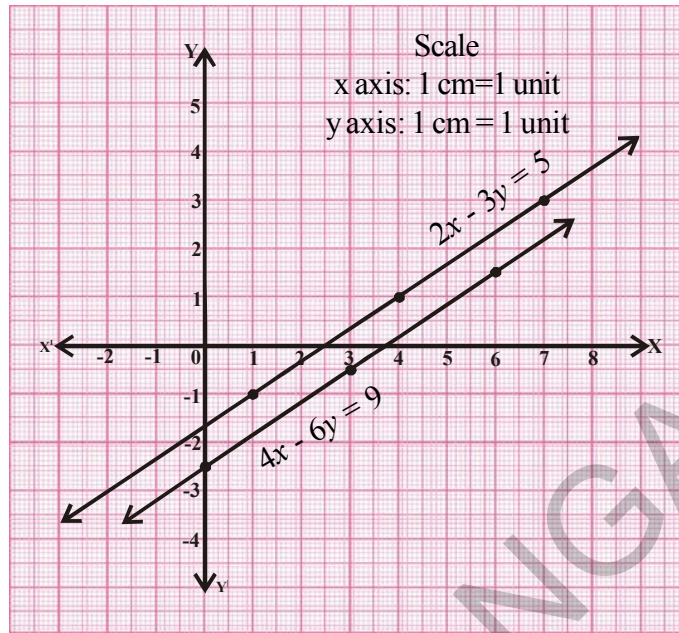
$$\frac{a_1}{a_2} = \frac{b_1}{b_2} \neq \frac{c_1}{c_2}$$

So the equations are inconsistent. They have no solutions and their graph is of parallel lines.

For the equation $4x - 6y = 15$		
x	$y = \frac{15 - 4x}{-6}$	(x, y)
0	$y = \frac{15 - 0}{-6} = \frac{-5}{2}$	$(0, -2.5)$
3	$y = \frac{15 - 4(3)}{-6} = \frac{-1}{2}$	$(3, -0.5)$
6	$y = \frac{15 - 4(6)}{-6} = \frac{3}{2}$	$(6, 1.5)$

For the equation $2x - 3y = 5$		
x	$y = \frac{5 - 2x}{-3}$	(x, y)
1	$y = \frac{5 - 2(1)}{-3} = -1$	$(1, -1)$
4	$y = \frac{5 - 2(4)}{-3} = 1$	$(4, 1)$
7	$y = \frac{5 - 2(7)}{-3} = 3$	$(7, 3)$





Do This

Check each of the given system of equations to see if it has a unique solution, infinite solutions or no solution. Solve them graphically.

(i) $2x + 3y = 1$
 $3x - y = 7$

(ii) $x + 2y = 6$
 $2x + 4y = 12$

(iii) $3x + 2y = 6$
 $6x + 4y = 18$



Try This

- For what value of 'p' the following pair of equations has a unique solution.
 $2x + py = -5$ and $3x + 3y = -6$
- Find the value of 'k' for which the pair of equations $2x - ky + 3 = 0$, $4x + 6y - 5 = 0$ represent parallel lines.
- For what value of 'k', the pair of equations $3x + 4y + 2 = 0$ and $9x + 12y + k = 0$ represents coincident lines.
- For what positive values of 'p', the following pair of linear equations have infinite solutions?
 $px + 3y - (p - 3) = 0$
 $12x + py - p = 0$

Let us look at some more examples.

Example-4. In a garden there are some bees and flowers. If one bee sits on each flower then one bee will be left. If two bees sit on each flower, one flower will be left. Find the number of bees and number of flowers.

Solution : Let the number of bees = x and
the number of flowers = y

If one bee sits on each flower then one bee will be left. So, $x = y + 1$



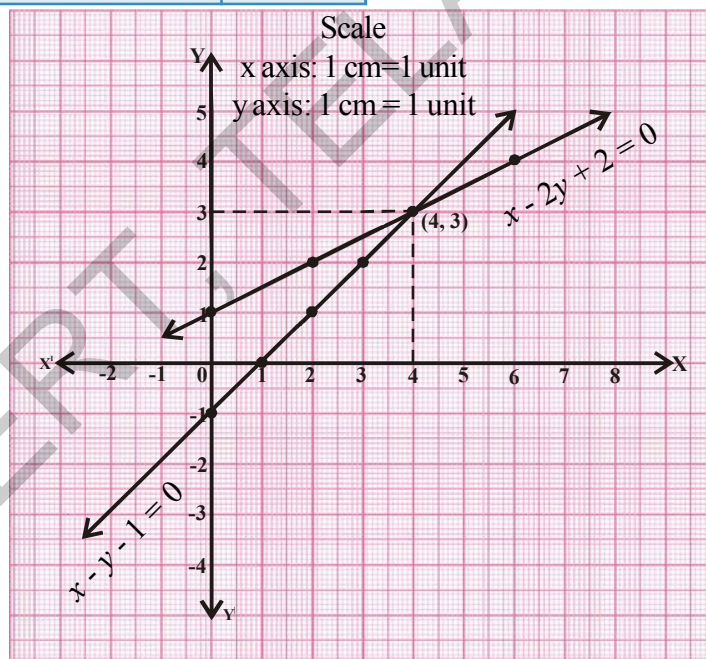
or $x - y - 1 = 0$... (1)

If two bees sit on each flower, one flower will be left. So, $y = \frac{x}{2} + 1$ then $x = 2(y - 1)$

or $x - 2y + 2 = 0$... (2)

For the equation $x - y - 1 = 0$		
x	$y = x - 1$	(x, y)
0	$y = 0 - 1 = -1$	$(0, -1)$
1	$y = 1 - 1 = 0$	$(1, 0)$
2	$y = 2 - 1 = 1$	$(2, 1)$
3	$y = 3 - 1 = 2$	$(3, 2)$
4	$y = 4 - 1 = 3$	$(4, 3)$

For the equation $x - 2y + 2 = 0$		
x	$y = \frac{x+2}{2}$	(x, y)
0	$y = \frac{0+2}{2} = 1$	$(0, 1)$
2	$y = \frac{2+2}{2} = 2$	$(2, 2)$
4	$y = \frac{4+2}{2} = 3$	$(4, 3)$
6	$y = \frac{6+2}{2} = 4$	$(6, 4)$



In the graph, $(4, 3)$ is the point of intersection. Therefore, there are 4 bees and 3 flowers.

Example-5. The perimeter of a rectangular plot is 32m. If the length is increased by 2m and the breadth is decreased by 1m, the area of the plot remains the same. Find the length and breadth of the plot.

Solution : Let length and breadth of the rectangular land be l and b respectively. Then,

$$\text{area} = lb$$

$$\text{and Perimeter} = 2(l + b) = 32 \text{ m}$$

$$\text{Then, } l + b = 16 \text{ or } l + b - 16 = 0 \quad \dots (1)$$

If the length is increased by 2 m, then new length is $l + 2$. Also breadth is decreased by 1 m; so new breadth is $b - 1$.

$$\text{Then, area} = (l + 2)(b - 1)$$

Since there is no change in the area,

$$(l + 2)(b - 1) = lb$$

$$lb - l + 2b - 2 = lb \quad \text{or} \quad lb - lb = l - 2b + 2$$

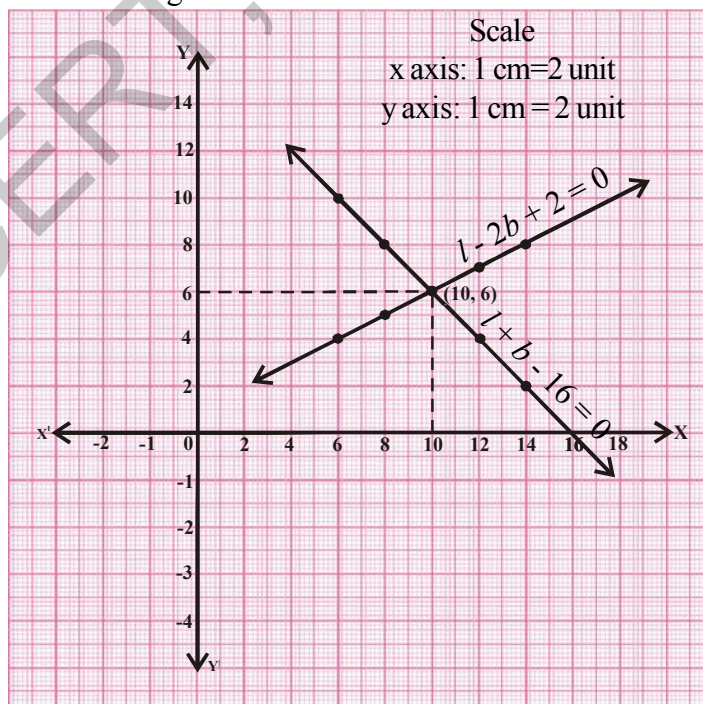
$$l - 2b + 2 = 0 \quad \dots (2)$$

For the equation $l + b - 16 = 0$		
l	$b = 16 - l$	(l, b)
6	$b = 16 - 6 = 10$	(6, 10)
8	$b = 16 - 8 = 8$	(8, 8)
10	$b = 16 - 10 = 6$	(10, 6)
12	$b = 16 - 12 = 4$	(12, 4)
14	$b = 16 - 14 = 2$	(14, 2)

For the equation $l - 2b + 2 = 0$		
l	$b = \frac{l+2}{2}$	(l, b)
6	$b = \frac{6+2}{2} = 4$	(6, 4)
8	$b = \frac{8+2}{2} = 5$	(8, 5)
10	$b = \frac{10+2}{2} = 6$	(10, 6)
12	$b = \frac{12+2}{2} = 7$	(12, 7)
14	$b = \frac{14+2}{2} = 8$	(14, 8)

So, original length of the plot is 10m and its breadth is 6m.

Taking measures of length on X-axis and measure of breadth on Y-axis, we get the graph





Exercise - 4.1

1. By comparing the ratios $\frac{a_1}{a_2}$, $\frac{b_1}{b_2}$, $\frac{c_1}{c_2}$, state whether the lines represented by the following pairs of linear equations intersect at a point / or parallel / or coincident.
- a) $5x - 4y + 8 = 0$
 $7x + 6y - 9 = 0$
- b) $9x + 3y + 12 = 0$
 $18x + 6y + 24 = 0$
- c) $6x - 3y + 10 = 0$
 $2x - y + 9 = 0$
2. Check whether the following equations are consistent or inconsistent. Solve them graphically.
- a) $3x + 2y = 5$
 $2x - 3y = 7$
- b) $2x - 3y = 8$
 $4x - 6y = 9$
- c) $\frac{3}{2}x + \frac{5}{3}y = 7$
 $9x - 10y = 12$
- d) $5x - 3y = 11$
 $-10x + 6y = -22$
- e) $\frac{4}{3}x + 2y = 8$
 $2x + 3y = 12$
- f) $x + y = 5$
 $2x + 2y = 10$
- g) $x - y = 8$
 $3x - 3y = 16$
- h) $2x + y - 6 = 0$
 $4x - 2y - 4 = 0$
- i) $2x - 2y - 2 = 0$
 $4x - 4y - 5 = 0$

Form equations for the following situations and solve them graphically.

3. Neha went to a shop to purchase some pants and skirts. When her friend asked her how many of each she had bought, she answered, "the number of skirts are two less than twice the number of pants purchased and the number of skirts is four less than four times the number of pants purchased."
Help her friend to find how many pants and skirts Neha bought.
4. 10 students of Class-X took part in a mathematics quiz. If the number of girls is 4 more than the number of boys, then find the number of boys and the number of girls who took part in the quiz.
5. 5 pencils and 7 pens together cost ₹50 whereas 7 pencils and 5 pens together cost ₹46. Find the cost of one pencil and one pen.
6. Half the perimeter of a rectangular garden is 36 m. If the length is 4m more than its width, then find the dimensions of the garden.
7. We have a linear equation $2x + 3y - 8 = 0$. Write another linear equation in two variables x and y such that the graphical representation of the pair so formed is intersecting lines.
Now, write two more linear equations so that one forms a pair of parallel lines and the second forms coincident line with the given equation.
8. The area of a rectangle gets reduced by 80 sq units, if its length is reduced by 5 units and breadth is increased by 2 units. If we increase the length by 10 units and decrease the breadth by 5 units then the area will be increased by 50 sq units. Find the length and breadth of the rectangle.



9. In a class, if three students sit on each bench, one student will be left. If four students sit on each bench, one bench will be left. Find the number of students and the number of benches in that class.

4.3 Algebraic Methods of Finding the Solutions for a Pair of Linear Equations

We have learnt how to solve a pair of linear equations graphically. But, the graphical method is not convenient in all cases where the point representing the solution has no integral co-ordinates.

For example, when the solution is of the form $(\sqrt{3}, 2\sqrt{7})$, $(-1.75, 3.3)$, $(\frac{4}{13}, \frac{1}{19})$,..... etc.

There is every possibility of making mistakes while plotting such co-ordinates on graph. Is there any alternative method of finding a solution? There are several methods, some of which we shall discuss now.

4.3.1 Substitution Method

This method is useful for solving a pair of linear equations in two variables where one variable can easily be written in terms of the other variable. To understand this method, let us consider it step-wise.

Step-1 : In one of the equations, express one variable in terms of the other variable. (For example variable y in terms of variable x .)

Step-2 : Substitute the value of y obtained in step 1 in the second equation.

Step-3 : Simplify the equation obtained in step 2 and find the value of x .

Step-4 : Substitute the value of x obtained in step 3 in the equation of step 1 and solve it for y .

Step-5 : Check the obtained solution by substituting the values of x and y in both the original equations.

Example-6. Solve the given pair of equations using substitution method.

$$2x - y = 5$$

$$3x + 2y = 11$$

Solution : $2x - y = 5$ (1)

$3x + 2y = 11$ (2)

Equation (1) can be written as (for the solution of y)

$$y = 2x - 5$$

Substituting in equation (2) we get

$$3x + 2(2x - 5) = 11$$



$$3x + 4x - 10 = 11$$

$$7x = 11 + 10 = 21$$

$$x = 21/7 = 3.$$

Substitute $x=3$ in equation (1)

$$2(3) - y = 5$$

$$y = 6 - 5 = 1$$

Substituting the values of x and y in equation (2), we get $3(3) + 2(1) = 9 + 2 = 11$

Both the equations are satisfied by $x = 3$ and $y = 1$.

Therefore, the required solution is $x = 3$ and $y = 1$.



Do This

Solve the following pairs of equation by using the substitution method.

1) $3x - 5y = -1$
 $x - y = -1$

2) $x + 2y = -1$
 $2x - 3y = 12$

3) $2x + 3y = 9$
 $3x + 4y = 5$

4) $x + \frac{6}{y} = 6$

5) $0.2x + 0.3y = 13$

6) $\sqrt{2}x + \sqrt{3}y = 0$

$3x - \frac{8}{y} = 5$

$0.4x + 0.5y = 2.3$

$\sqrt{3}x - \sqrt{8}y = 0$

4.3.2 Elimination Method

In this method, first we eliminate (remove) one of the two variables by equating its coefficients. This gives a single equation with one variable which can be solved to get the value of the other variable. To understand this method, let us consider it stepwise.

Step-1: Write both the equations in the form of $ax + by = c$.

Step-2: Make the coefficients of one of the variables, equal by multiplying each equation by suitable real numbers.

Step-3: If the variable to be eliminated has the same sign in both equations, subtract one equation from the other to get an equation in one variable. If they have opposite signs then add.

Step-4: Solve the equation for the remaining variable.

Step-5: Substitute the value of this variable in any one of the original equations and find the value of the eliminated variable.

Example-7. Solve the following pair of linear equations using elimination method.

$$3x + 2y = 11$$

$$2x + 3y = 4$$



$$\begin{aligned} \text{Solution : } \quad 3x + 2y &= 11 & (1) \\ 2x + 3y &= 4 & (2) \end{aligned}$$

Let us eliminate 'y' from the given equations. The coefficients of 'y' in the given equations are 2 and 3. L.C.M. of 2 and 3 is 6. So, multiply equation (1) by 3 and equation (2) by 2.

$$\begin{array}{r} \text{Equation (1)} \times 3 \quad 9x + 6y = 33 \\ \text{Equation (2)} \times 2 \quad 4x + 6y = 8 \\ \hline \quad \quad \quad (-) \quad (-) \quad (-) \\ \quad \quad \quad 5x \quad = \quad 25 \\ \quad \quad \quad x = \frac{25}{5} = 5 \end{array}$$

Substitute $x = 5$, in equation (1)

$$3(5) + 2y = 11$$

$$2y = 11 - 15 = -4 \Rightarrow y = \frac{-4}{2} = -2$$

Therefore, the required solution is $x = 5, y = -2$.



Do This

Solve each of the following pairs of equations by the elimination method.

1. $8x + 5y = 9$
 $3x + 2y = 4$

2. $2x + 3y = 8$
 $4x + 6y = 7$

3. $3x + 4y = 25$
 $5x - 6y = -9$



Try This

Solve the given pair of linear equations

$$(a - b)x + (a + b)y = a^2 - 2ab - b^2$$

$$(a + b)(x + y) = a^2 + b^2$$

Let us see some more examples:

Example-8. Rubina went to the bank to withdraw ₹2000. She asked the cashier to give the cash in ₹50 and ₹100 notes only. She got 25 notes in all. Can you tell how many notes each of ₹50 and ₹100 she received?

Solution : Let the number of ₹50 notes be x ;

Let the number of ₹100 notes be y ;

$$\text{then, } x + y = 25 \quad (1)$$

$$\text{and } 50x + 100y = 2000 \quad (2)$$

Method I: Solution through the **substitution** method:



From equation (1)
Substituting in equation (2)

$$\begin{aligned}x &= 25 - y \\50(25 - y) + 100y &= 2000 \\1250 - 50y + 100y &= 2000 \\50y &= 2000 - 1250 = 750\end{aligned}$$

$$y = \frac{750}{50} = 15$$

$$x = 25 - 15 = 10$$

Hence, Rubina received ten ₹50 notes and fifteen ₹100 notes.

Method II: Solution through the **elimination** method:

In the equations, coefficients of x are 1 and 50 respectively. So,

$$\text{Equation (1)} \times 50 : 50x + 50y = 1250$$

$$\text{Equation (2)} \times 1 : 50x + 100y = 2000 \quad \text{same sign, so subtract}$$

$$\begin{array}{r}(-) \quad (-) \quad (-) \\50x + 50y = 1250 \\-(50x + 100y = 2000) \\ \hline-50y = -750\end{array}$$

or $y = \frac{-750}{-50} = 15$

Substitute y in equation (1) $x + 15 = 25$

$$x = 25 - 15 = 10$$

Hence Rubina received ten ₹50 notes and fifteen ₹100 rupee notes.

Example-9. In a competitive exam, 3 marks were awarded for every correct answer and 1 mark was deducted for every wrong answer. Madhu scored 40 marks in this exam. Had 4 marks been awarded for each correct answer and 2 marks deducted for each incorrect answer, Madhu would have scored 50 marks. If how many questions were there in the test? (Madhu had attempted all questions.)

Solution : Let the number of correct answers be x
and the number of wrong answers be y .

When 3 marks are given for each correct answer and 1 mark deducted for each wrong answer, his score is 40 marks.

$$\text{So, } 3x - y = 40 \quad (1)$$

His score would have been 50 marks if 4 marks were given for each correct answer and 2 marks deducted for each wrong answer.

$$\text{Thus, } 4x - 2y = 50 \quad (2)$$



Substitution method

From equation (1),

$$y = 3x - 40$$

Substituting in equation (2)

$$4x - 2(3x - 40) = 50$$

$$4x - 6x + 80 = 50$$

$$-2x = 50 - 80 = -30$$

$$x = \frac{-30}{-2} = 15$$

Substitute the value of x in equation (1)

$$3(15) - y = 40$$

$$45 - y = 40$$

$$y = 45 - 40 = 5$$

\therefore Total number of questions = $15 + 5 = 20$



Do This

Use the elimination method to solve the example-9.

Example-10. Mary told her daughter, "Seven years ago, I was seven times as old as you were then. Also, three years from now, I shall be three times as old as you will be." Find the present age of Mary and her daughter.

Solution : Let Mary's present age be x years and her daughter's age be y years.

Then, seven years ago Mary's age was $(x - 7)$ and daughter's age was $(y - 7)$.

$$x - 7 = 7(y - 7)$$

$$x - 7 = 7y - 49$$

$$x - 7y + 42 = 0 \quad (1)$$

Three years hence, Mary's age will be $x + 3$ and daughter's age will be $y + 3$.

$$x + 3 = 3(y + 3)$$

$$x + 3 = 3y + 9$$

$$x - 3y - 6 = 0 \quad (2)$$

Elimination method

$$\text{Equation 1} \quad x - 7y = -42$$

$$\text{Equation 2} \quad x - 3y = 6$$

$$\begin{array}{r} (-) \quad (+) \quad (-) \\ \hline \end{array}$$

$$-4y = -48$$

same sign for x , so subtract eq. (2) from eq. (1).



$$y = \frac{-48}{-4} = 12$$

Substitute the value of y in equation (2)

$$x - 3(12) - 6 = 0$$

$$x = 36 + 6 = 42$$

Therefore, Mary's present age is 42 years and her daughter's age is 12 years.



Do This

Solve example-10 by the substitution method.

Example-11. A publisher is planned to produce a new textbook. The fixed costs (reviewing, editing, typesetting and so on) are ₹ 320000. Besides that, he also spends another ₹ 31.25 in producing each book. The wholesale price (the amount received by the publisher) is ₹ 43.75 per book. How many books must the publisher sell to break even, i.e., so that the cost of production will equal revenues?

The point which corresponds to how much money you have to earn through sales in order to equal the money you spent in production is **break even point**.

Solution : The publisher breaks even when costs equal revenues. If x represents the number of books printed and sold and y be the breakeven point, then the cost and revenue equations for the publisher are

Cost equation is given by $y = 320000 + 31.25x$ (1)

Revenue equation is given by $y = 43.75x$ (2)

Using the second equation to substitute for y in the first equation, we have

$$43.75x = ₹ 320000 + 31.25x$$

$$12.5x = ₹ 320000$$

$$x = \frac{320000}{12.5} = 25,600$$

Thus, the publisher will break even when 25,600 books are printed and sold.



Exercise - 4.2

Form a pair of linear equations for each of the following problems and find their solution.

- The ratio of incomes of two persons is 9 : 7 and the ratio of their expenditures is 4 : 3. If each of them manages to save ₹2000 per month then find their monthly income.
- The sum of a two digit number and the number obtained by reversing the digits is 66. If the digits of the number differ by 2, find the number. How many such numbers are there?



3. The larger of two supplementary angles exceeds the smaller by 18° . Find the angles.
4. The taxi charges in Hyderabad have two components: fixed and per kilometer charge. Upto first 3 km you will be charged a certain minimum amount. From there onwards you have to pay additionally for every kilometer travelled. For the first 10 km, the charge paid is ₹166. For a journey of 15 km. the charge paid is ₹256.
 - i. What are the fixed charges and charge per km?
 - ii. How much does a person have to pay for travelling a distance of 25 km?
5. A fraction will be equal to $\frac{4}{5}$ if 1 is added to both numerator and denominator. If, however, 5 is subtracted from both numerator and denominator the fraction will be equal to $\frac{1}{2}$. What is the fraction?
6. Places A and B are 100 km apart on a highway. One car starts from point A and another from point B at the same time at different speeds. If the cars travel in the same direction, they meet in 5 hours. If they travel towards each other, they meet in 1 hour. What are the speeds of the two cars?
7. Two angles are complementary. The larger angle is 3° less than twice the measure of the smaller angle. Find the measure of each angle.
8. A dictionary has a total of 1382 pages. It is broken up into two parts. The second part of the book has 64 pages more than the first part. How many pages are in each part of the book?
9. A chemist has two solutions of hydrochloric acid in stock. One is 50% solution and the other is 80% solution. How much of each should be used to obtain 100ml of a 68% solution.
10. You have ₹12,000/- saved amount, and wants to invest it in two schemes yielding 10% and 15% interest. How much amount should be invested in each scheme so that you should get overall 12% interest.

4.4 Equations Reducible to a Pair of Linear Equations in Two Variables

Now we shall discuss the solution of pairs of equations which are not linear but can be reduced to linear form by making suitable substitutions. Let us see an example:

Example-12. Solve the following pair of equations.

$$\frac{2}{x} + \frac{3}{y} = 13$$

$$\frac{5}{x} - \frac{4}{y} = -2$$

Solution : Observe the given pair of equations. They are not linear equations. (Why?)



We have $2\left(\frac{1}{x}\right) + 3\left(\frac{1}{y}\right) = 13$ (1)

$$5\left(\frac{1}{x}\right) - 4\left(\frac{1}{y}\right) = -2 \quad (2)$$

If we substitute $\frac{1}{x} = p$ and $\frac{1}{y} = q$, we get the following pair of linear equations:

$$2p + 3q = 13 \quad (3)$$

$$5p - 4q = -2 \quad (4)$$

Coefficients of q are 3 and 4 and their LCM is 12. Using the elimination method:

Equation (3) $\times 4$ $8p + 12q = 52$

Equation (4) $\times 3$ $15p - 12q = -6$ 'q' terms have opposite sign, so we add the two equations.

$$23p = 46$$

$$p = \frac{46}{23} = 2$$

Substitute the value of p in equation (3)

$$2(2) + 3q = 13$$

$$3q = 13 - 4 = 9$$

$$q = \frac{9}{3} = 3$$

But, $\frac{1}{x} = p = 2 \Rightarrow x = \frac{1}{2}$

$\frac{1}{y} = q = 3 \Rightarrow y = \frac{1}{3}$



Example-13. Kavitha thought of constructing 2 more rooms in her house. She enquired about the labour and time estimates. She came to know that 6 men and 8 women could finish this work in 14 days. But she wished to complete that work in only 10 days. When she enquired elsewhere, she was told that 8 men and 12 women could finish the work in 10 days. Find out how much time would be taken to finish the work if one man or one woman worked alone.

Solution : Let the time taken by one man to finish the work = x days.



The portion of work done by one man in one day $= \frac{1}{x}$

Let the time taken by one woman to finish the work $= y$ days.

The portion of work done by one woman in one day $= \frac{1}{y}$

Now, 8 men and 12 women can finish the work in 10 days.

So the portion of work done by 8 men and 12 women in one day $= \frac{1}{10}$ (1)

Also, the portion of work done by 8 men in one day is $8 \times \frac{1}{x} = \frac{8}{x}$

Similarly, the portion of work done by 12 women in one day is $12 \times \frac{1}{y} = \frac{12}{y}$

Total portion of work done by 8 men and 12 women in one day $= \frac{8}{x} + \frac{12}{y}$ (2)

Equating equations (1) and (2) $\left(\frac{8}{x} + \frac{12}{y}\right) = \frac{1}{10}$

$$10 \left(\frac{8}{x} + \frac{12}{y}\right) = 1$$

$$\frac{80}{x} + \frac{120}{y} = 1 \quad (3)$$

Also, 6 men and 8 women can finish the work in 14 days.

The portion of work done by 6 men and 8 women in one day $= \frac{6}{x} + \frac{8}{y} = \frac{1}{14}$

$$\Rightarrow 14 \left(\frac{6}{x} + \frac{8}{y}\right) = 1$$

$$\left(\frac{84}{x} + \frac{112}{y}\right) = 1 \quad (4)$$



Observe equations (3) and (4). Are they linear equations? How do we solve these equations?

We can convert them into linear equations by substituting $\frac{1}{x} = u$ and $\frac{1}{y} = v$.

Equation (3) becomes $80u + 120v = 1$ (5)

Equation (4) becomes $84u + 112v = 1$ (6)

L.C.M. of 80 and 84 is 1680. Using the elimination method,

Equation (3) $\times 21$ $(21 \times 80)u + (21 \times 120)v = 21$

Equation (4) $\times 20$ $(20 \times 84)u + (20 \times 112)v = 20$

$$\begin{array}{r} \cancel{1680}u + 2520v = 21 \\ \cancel{1680}u + 2240v = 20 \\ \hline (-) \quad (-) \quad (-) \\ 280v = 1 \end{array}$$

Same sign for u , so subtract

$$v = \frac{1}{280}$$

Substitute in equation (5) $80u + \left(120 \times \frac{1}{280}\right) = 1$

$$80u = 1 - \frac{3}{7} = \frac{7-3}{7} = \frac{4}{7}$$

$$u = \frac{\cancel{4}}{7} \times \frac{1}{\cancel{80}_{20}} = \frac{1}{140}$$



So one man alone can finish the work in 140 days and one woman alone can finish the work in 280 days.

Example-14. A man travels 370 km partly by train and partly by car. If he covers 250 km by train and the rest by car, it takes him 4 hours. But if he travels 130 km by train and the rest by car, it takes 18 minutes more. Find the speed of the train and that of the car.

Solution : Let the speed of the train be x km per hour and that of the car be y km per hour. Also,

we know that $\text{time} = \frac{\text{Distance}}{\text{Speed}}$

In situation 1, time spent travelling by train = $\frac{250}{x}$ hrs

And time spent travelling by car = $\frac{120}{y}$ hrs



So, total time taken = time spent in train + time spent in car = $\frac{250}{x} + \frac{120}{y}$

But, total time of journey is 4 hours, so

$$\frac{250}{x} + \frac{120}{y} = 4$$

$$\frac{125}{x} + \frac{60}{y} = 2 \quad \rightarrow (1)$$

Again, when he travels 130 km by train and the rest by car

Time taken by him to travel 130 km by train = $\frac{130}{x}$ hrs

Time taken by him to travel 240 km (370 - 130) by car = $\frac{240}{y}$ hrs

Total time taken = $\frac{130}{x} + \frac{240}{y}$

But, it is given that the time of journey is 4 hrs 18 min i.e., $4\frac{18}{60}$ hrs = $4\frac{3}{10}$ hrs

$$\text{So, } \frac{130}{x} + \frac{240}{y} = \frac{43}{10} \quad \rightarrow (2)$$

Substitute $\frac{1}{x} = a$ and $\frac{1}{y} = b$ in equations (1) and (2)

$$125a + 60b = 2 \quad \rightarrow (3)$$

$$130a + 240b = 43/10 \quad \rightarrow (4)$$

For 60 and 240, LCM is 240. By using the elimination method,

$$\text{Equation (3)} \times 4 \quad 500a + 240b = 8$$

$$\text{Equation (4)} \times 1 \quad 130a + 240b = \frac{43}{10} \quad (\text{Same sign, so subtract})$$

$$\underline{(-) \quad (-) \quad (-)}$$

$$370a = 8 - \frac{43}{10} = \frac{80 - 43}{10} = \frac{37}{10}$$



$$a = \frac{\cancel{37}}{10} \times \frac{1}{\frac{\cancel{370}}{10}} = \frac{1}{100}$$

Substitute $a = \frac{1}{100}$ in equation (3)

$$\left(\frac{\cancel{125}^5}{\cancel{100}_4} \times \frac{1}{\cancel{100}} \right) + 60b = 2$$

$$60b = 2 - \frac{5}{4} = \frac{8-5}{4} = \frac{3}{4}$$

$$b = \frac{\cancel{3}}{4} \times \frac{1}{\frac{\cancel{60}}{20}} = \frac{1}{80}$$

So $a = \frac{1}{100}$ and $b = \frac{1}{80}$

So $\frac{1}{x} = \frac{1}{100}$ and $\frac{1}{y} = \frac{1}{80}$

$x = 100$ km/hr and $y = 80$ km/hr.

So, speed of the train was 100 km/hr and speed of the car was 80 km/hr.



Exercise - 4.3

Solve each of the following pairs of equations by reducing them to a pair of linear equations.

i) $\frac{5}{x-1} + \frac{1}{y-2} = 2$

$$\frac{6}{x-1} - \frac{3}{y-2} = 1$$

iii) $\frac{2}{\sqrt{x}} + \frac{3}{\sqrt{y}} = 2$

$$\frac{4}{\sqrt{x}} - \frac{9}{\sqrt{y}} = -1$$

v) $\frac{5}{x+y} - \frac{2}{x-y} = -1$

$$\frac{15}{x+y} + \frac{7}{x-y} = 10$$

ii) $\frac{x+y}{xy} = 2$

$$\frac{x-y}{xy} = 6$$

iv) $6x+3y=6xy$

$$2x + 4y = 5xy$$

vi) $\frac{2}{x} + \frac{3}{y} = 13$

$$\frac{5}{x} - \frac{4}{y} = -2$$



$$\text{vii) } \frac{10}{x+y} + \frac{2}{x-y} = 4$$

$$\frac{15}{x+y} - \frac{5}{x-y} = -2$$

$$\text{viii) } \frac{1}{3x+y} + \frac{1}{3x-y} = \frac{3}{4}$$

$$\frac{1}{2(3x+y)} - \frac{1}{2(3x-y)} = \frac{-1}{8}$$

2. Formulate the following problems as a pair of equations and then find their solutions.

- i. A boat goes 30 km upstream and 44 km downstream in 10 hours. In 13 hours it can go 40 km upstream and 55 km downstream. Determine the speed of the stream and that of the boat in still water.
- ii. Rahim travels 600 km to his home partly by train and partly by car. He takes 8 hours if he travels 120 km by train and rest by car. He takes 20 minutes more if he travels 200 km by train and rest by car. Find the speed of the train and the car.
- iii. 2 women and 5 men can together finish an embroidery work in 4 days while 3 women and 6 men can finish it in 3 days. Find the time to be taken by 1 woman alone and 1 man alone to finish the work.



Optional Exercise
[For extensive learning]

1. Solve the following equations:-

$$\text{(i) } \frac{2x}{a} + \frac{y}{b} = 2$$

$$\frac{x}{a} - \frac{y}{b} = 4$$

$$\text{(iii) } \frac{x}{7} + \frac{y}{3} = 5$$

$$\frac{x}{2} - \frac{y}{9} = 6$$

$$\text{(v) } \frac{ax}{b} - \frac{by}{a} = a + b$$

$$ax - by = 2ab$$

$$\text{(ii) } \frac{x+1}{2} + \frac{y-1}{3} = 8$$

$$\frac{x-1}{3} + \frac{y+1}{2} = 9$$

$$\text{(iv) } \sqrt{3}x + \sqrt{2}y = \sqrt{3}$$

$$\sqrt{5}x + \sqrt{3}y = \sqrt{3}$$

$$\text{(vi) } 2^x + 3^y = 17$$

$$2^{x+2} - 3^{y+1} = 5$$

2. Animals in an experiment are to be kept on a strict diet. Each animal is to receive among other things 20g of protein and 6g of fat. The laboratory technicians purchased two food mixes, A and B. Mix A has 10% protein and 6% fat. Mix B has 20% protein and 2% fat. How many grams of each mix should be used?



Suggested Projects

- Construct some pairs of linear equations from daily life situations and find solutions of the equations by using graphs.



What We Have Discussed



1. Two linear equations in the same two variables are called a pair of linear equations in two variables.
$$a_1x + b_1y + c_1 = 0 \quad (a_1^2 + b_1^2 \neq 0)$$
$$a_2x + b_2y + c_2 = 0 \quad (a_2^2 + b_2^2 \neq 0)$$
where $a_1, a_2, b_1, b_2, c_1, c_2$ are real numbers.
2. A pair of linear equations in two variables can be solved by using various methods.
3. The graph of a pair of linear equations in two variables is represented by two lines.
 - i. If the lines intersect at a point then the point gives the unique solution of the two equations. In this case, the pair of equations is consistent and independent.
 - ii. If the lines coincide, then there are infinitely many solutions - each point on the line being a solution. In this case, the pair of equations is consistent and dependent.
 - iii. If the lines are parallel then the pair of equations has no solution. In this case, the pair of equations is inconsistent.
4. We have discussed the following methods for finding the solution(s) of a pair of linear equations.
 - i. Model Method.
 - ii. Graphical Method
 - iii. Algebraic methods - Substitution method and Elimination method.
5. There exists a relation between the coefficients and nature of system of equations.
 - i. If $\frac{a_1}{a_2} \neq \frac{b_1}{b_2}$ then the pair of linear equations is consistent.
 - ii. If $\frac{a_1}{a_2} = \frac{b_1}{b_2} \neq \frac{c_1}{c_2}$ then the pair of linear equations is inconsistent.
 - iii. If $\frac{a_1}{a_2} = \frac{b_1}{b_2} = \frac{c_1}{c_2}$ then the pair of linear equations is dependent and consistent.
6. There are several situations which can be mathematically represented by two equations that are not linear to start with. But we can alter them so that they will be reduced to a pair of linear equations.

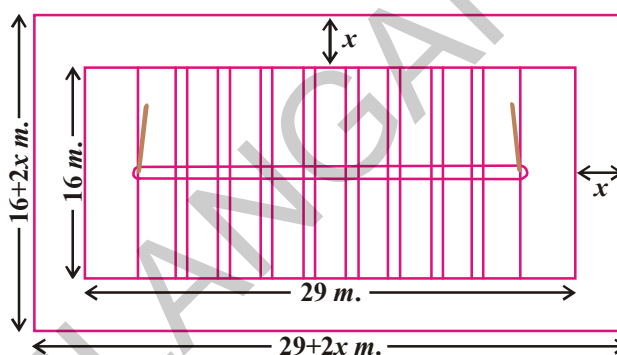




5.1 Introduction

Sports committee of Dhannur High School wants to construct a Kho-Kho court of dimensions $29 \text{ m} \times 16 \text{ m}$. This is to be laid in a rectangular plot of area 558 m^2 . They want to leave space of equal width all around the court for the spectators. What would be the width of the space for spectators? Would it be enough?

Suppose, the width of the space is x meter. So, according to the figure the length of the plot would be $(29 + 2x)$ meter.



And, breadth of the rectangular plot would be $(16 + 2x)$ m.

Therefore, area of the rectangular plot = length \times breadth
 $= (29 + 2x)(16 + 2x)$

Since the area of the plot $= 558 \text{ m}^2$ is given

$$\therefore (29 + 2x)(16 + 2x) = 558$$

$$\therefore 4x^2 + 90x + 464 = 558$$

$$4x^2 + 90x - 94 = 0$$

Dividing both sides by 2

$$2x^2 + 45x - 47 = 0 \quad \dots (1)$$

In the previous class we solved the linear equations of the form $ax + b = c$ to find the value of ' x '. Similarly, the value of x from the above equation will give the possible width of the space for spectators.

Can you think of more such examples where we have to find the quantities, like in the above example using equations.

Let us consider another example:

Rani has a square metal sheet. She removed squares of side 9 cm from each corner of this sheet. Of the remaining sheet, she turned up the sides to form an open box as shown. The capacity of the box is 144 cm^3 . Can we find out the original dimensions of the metal sheet?



Suppose the side of the square piece of metal sheet be 'x' cm.

Then, the dimensions of the box are

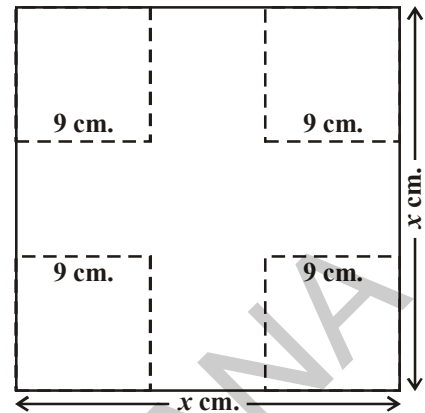
$$9 \text{ cm} \times (x-18) \text{ cm} \times (x-18) \text{ cm}$$

Since volume of the box is 144 cm^3

$$9(x-18)(x-18) = 144$$

$$(x-18)^2 = 16$$

$$x^2 - 36x + 308 = 0 \quad \dots (2)$$

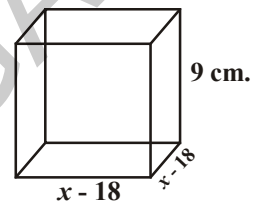


So, the value of 'x' satisfying the above equation will become the side of the metal sheet taken earlier.

Let us observe the L.H.S of equation (1) and (2)

Are they quadratic polynomials?

We have studied quadratic polynomials of the form $ax^2 + bx + c$, $a \neq 0$ in one of the previous chapters.



Since, the LHS of the above equations (1) and (2) are quadratic polynomials and the RHS is 0 they are called quadratic equations.

In this chapter we will study quadratic equations and methods to find their roots.

5.2 Quadratic Equations

A quadratic equation in the variable x is an equation of the form $ax^2 + bx + c = 0$, where a, b, c are real numbers and $a \neq 0$. For example, $2x^2 + x - 300 = 0$ is a quadratic equation, Similarly, $2x^2 - 3x + 1 = 0$, $4x - 3x^2 + 2 = 0$ and $1 - x^2 + 300 = 0$ are also quadratic equations.

In fact, any equation of the form $p(x) = 0$, where $p(x)$ is a polynomial of degree 2, is a quadratic equation. When we write the terms of $p(x)$ in descending order of their degrees, then we get the standard form of the equation. That is, $ax^2 + bx + c = 0$, $a \neq 0$ is called the standard form of a quadratic equation and $y = p(x) = ax^2 + bx + c$ is called a quadratic function.



Try This

Check whether the following equations are quadratic equations or not ?

(i) $x^2 - 6x - 4 = 0$

(ii) $x^3 - 6x^2 + 2x - 1 = 0$

(iii) $7x = 2x^2$

(iv) $x^2 + \frac{1}{x^2} = 2$ ($x \neq 0$)

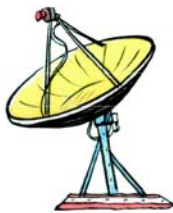
(v) $(2x + 1)(3x + 1) = b(x - 1)(x - 2)$ (vi) $3y^2 = 192$



There are various situations described by quadratic functions. Some of them are:-



1. When a rocket is fired upward, then the path of the rocket is defined by a 'quadratic function.'
2. Shapes of the satellite dish, reflecting mirror in a telescope, lens of the eye glasses and orbits of the celestial objects are defined by the quadratic functions.



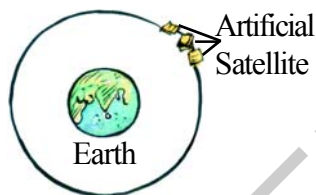
Satellite Dish



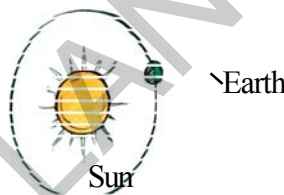
Reflecting Mirror



Lens of Spectacles



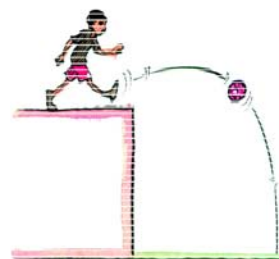
Artificial Satellite



Sun

Earth

3. The path of a projectile is defined by a quadratic function.



4. When the brakes are applied to a vehicle, the stopping distance is calculated by using a quadratic equation.

Example-1. Represent the following situations with suitable mathematical equations.

- i. Sridhar and Rajendar together have 45 marbles. Both of them lost 5 marbles each, and the product of the number of marbles they now have is 124. Form the quadratic equation to find how many marbles each of them had previously.

Solution : i. Let Sridhar has x marbles.

Then, the number of marbles with Rajendar = $45 - x$ (Why?).

The number of marbles left with Sridhar, when he lost 5 marbles = $x - 5$

The number of marbles left with Rajendar, when he lost 5 marbles = $(45 - x) - 5$
 $= 40 - x$



$$\begin{aligned}\text{Therefore, their product} &= (x - 5)(40 - x) \\ &= 40x - x^2 - 200 + 5x \\ &= -x^2 + 45x - 200\end{aligned}$$

$$\text{So, } -x^2 + 45x - 200 = 124 \text{ (Given data)}$$

$$\text{i.e., } -x^2 + 45x - 324 = 0$$

$$\text{i.e., } x^2 - 45x + 324 = 0 \quad (\text{Multiply both sides by } -1)$$

Therefore, the value of 'x', satisfying the quadratic equation $x^2 - 45x + 324 = 0$ will give the number of marbles with Sridhar at the beginning.

$$\therefore x^2 - 45x + 324 = 0 \text{ is the required mathematical equation.}$$

- ii. The hypotenuse of a right triangle is 25 cm. We know that the difference in lengths of the other two sides is 5 cm. Find the required quadratic equation to find out the length of the two sides?

Solution: Let the length of the smaller side be x cm

Then length of the longer side = $(x + 5)$ cm

Given length of the hypotenuse = 25 cm

We know that in a right angled triangle

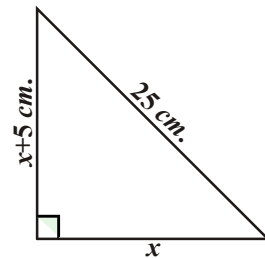
$$(\text{side})^2 + (\text{side})^2 = (\text{hypotenuse})^2$$

$$\text{So, } x^2 + (x + 5)^2 = (25)^2$$

$$x^2 + x^2 + 10x + 25 = 625$$

$$2x^2 + 10x - 600 = 0$$

$$x^2 + 5x - 300 = 0$$



Value of x from the above equation will give the possible value of length of sides of the given right angled triangle.

Example-2. Check whether the following are quadratic equations:

i. $(x - 2)^2 + 1 = 2x - 3$

ii. $x(x + 1) + 8 = (x + 2)(x - 2)$

iii. $x(2x + 3) = x^2 + 1$

iv. $(x + 2)^3 = x^3 - 4$

Solution : i. LHS = $(x - 2)^2 + 1 = x^2 - 4x + 4 + 1 = x^2 - 4x + 5$

Therefore, $(x - 2)^2 + 1 = 2x - 3$ can be written as

$$x^2 - 4x + 5 = 2x - 3$$



$$\Rightarrow x^2 - 6x + 8 = 0$$

It is in the form of $ax^2 + bx + c = 0$.

Therefore, the given equation is a quadratic equation.

ii. Here LHS = $x(x + 1) + 8 = x^2 + x + 8$

and RHS = $(x + 2)(x - 2) = x^2 - 4$

Therefore, $x^2 + x + 8 = x^2 - 4$

$$x^2 + x + 8 - x^2 + 4 = 0$$

$$\Rightarrow x + 12 = 0$$

It is not in the form of $ax^2 + bx + c = 0$, ($a \neq 0$)

Therefore, the given equation is not a quadratic equation.

iii. Here, LHS = $x(2x + 3) = 2x^2 + 3x$

So, $x(2x + 3) = x^2 + 1$ can be rewritten as

$$2x^2 + 3x = x^2 + 1$$

Therefore, we get $x^2 + 3x - 1 = 0$

It is in the form of $ax^2 + bx + c = 0$.

So, the given equation is a quadratic equation.

iv. Here, LHS = $(x + 2)^3 = (x + 2)^2(x + 2)$

$$= (x^2 + 4x + 4)(x + 2)$$

$$= x^3 + 2x^2 + 4x^2 + 8x + 4x + 8$$

$$= x^3 + 6x^2 + 12x + 8$$

Therefore, $(x + 2)^3 = x^3 - 4$ can be rewritten as

$$x^3 + 6x^2 + 12x + 8 = x^3 - 4$$

$$\Rightarrow 6x^2 + 12x + 12 = 0 \quad \text{or,} \quad x^2 + 2x + 2 = 0$$

It is in the form of $ax^2 + bx + c = 0$. So, the given equation is a quadratic equation.

Remark : In (ii) above, the given equation appears to be a quadratic equation, but it is not a quadratic equation. In (iv) above, the given equation appears to be a cubic equation But it turns out to be a quadratic equation.

As you can see, often we need to simplify the given equation before deciding whether it is quadratic or not.





Exercise - 5.1

- Check whether the following are quadratic equations :
 - $(x + 1)^2 = 2(x - 3)$
 - $x^2 - 2x = (-2)(3 - x)$
 - $(x - 2)(x + 1) = (x - 1)(x + 3)$
 - $(x - 3)(2x + 1) = x(x + 5)$
 - $(2x - 1)(x - 3) = (x + 5)(x - 1)$
 - $x^2 + 3x + 1 = (x - 2)^2$
 - $(x + 2)^3 = 2x(x^2 - 1)$
 - $x^3 - 4x^2 - x + 1 = (x - 2)^3$
- Represent the following situations in the form of quadratic equations :
 - The area of a rectangular plot is 528 m^2 . The length of the plot is one metre more than twice its breadth. We need to find the length and breadth of the plot.
 - The product of two consecutive positive integers is 306. We need to find the integers.
 - Rohan's mother is 26 years older than him. The product of their ages after 3 years will be 360 years. We need to find Rohan's present age.
 - A train travels a distance of 480 km at a uniform speed. If the speed had been 8 km/h less, then it would have taken 3 hours more to cover the same distance. We need to find the speed of the train.

5.3 Solution of a Quadratic Equation by Factorisation

We have learned to represent some of the daily life situations in the form of quadratic equation with an unknown variable 'x'.

Now, we need to find the value of x .

Consider the quadratic equation $2x^2 - 3x + 1 = 0$. If we replace x by 1. Then, we get $2 \times (1)^2 - (3 \times 1) + 1 = 0 = \text{RHS of the equation}$. Since $x = 1$ satisfies the equation, we say that 1 is a root / solution of the quadratic equation $2x^2 - 3x + 1 = 0$.

In general, a real number α is called a root of the quadratic equation $ax^2 + bx + c = 0$, if $a\alpha^2 + b\alpha + c = 0$. We also say that $x = \alpha$ is a **solution of the quadratic equation**, or α **satisfies the quadratic equation**.

Let's discuss the method of finding roots of a quadratic equation.



Example-3. Find the roots of the equation $2x^2 - 5x + 3 = 0$, by factorisation.

Solution : Let us split the middle term first.

To split middle term in $2x^2 - 5x + 3 = 0$, we need to find 'p' and 'q', such that

$$p + q = b = -5 \text{ and } p \times q = a \times c = 2 \times 3 = 6$$

For this we have to list out all possible pairs of factors of 6. They are (1, 6), (-1, -6); (2, 3); (-2, -3). From the list, it is clear that the pair (-2, -3) will satisfy our condition $p + q = -5$ and $p \times q = 6$.

The middle term '-5x' can be written as '-2x - 3x'.

$$\text{So, } 2x^2 - 5x + 3 = 2x^2 - 2x - 3x + 3 = 2x(x - 1) - 3(x - 1) = (2x - 3)(x - 1)$$

$$\text{Now, } 2x^2 - 5x + 3 = 0 \text{ can be rewritten as } (2x - 3)(x - 1) = 0.$$

i.e., either $2x - 3 = 0$ or $x - 1 = 0$.

$$\text{Now, } 2x - 3 = 0 \text{ gives } x = \frac{3}{2} \text{ or } x - 1 = 0 \text{ gives } x = 1.$$

So, $x = \frac{3}{2}$ or $x = 1$ are the solutions of the given quadratic equation.

In other words, 1 or $\frac{3}{2}$ are the roots of the equation $2x^2 - 5x + 3 = 0$.



Do This

Find the roots of the following equations using factorisation method.

(i) $x^2 + 5x + 6 = 0$

(ii) $x^2 - 5x + 6 = 0$

(iii) $x^2 + 5x - 6 = 0$

(iv) $x^2 - 5x - 6 = 0$



Try This

Check whether 1 and $\frac{3}{2}$ are the roots of the equation $2x^2 - 5x + 3 = 0$.

Note that we have found the roots of $2x^2 - 5x + 3 = 0$ by factorising $2x^2 - 5x + 3$ into two linear factors and equating each factor to zero.



Example 4 : Find the roots of the equation $x - \frac{1}{3x} = \frac{1}{6}$ ($x \neq 0$)

Solution : We have $x - \frac{1}{3x} = \frac{1}{6} \Rightarrow 6x^2 - x - 2 = 0$

$$\begin{aligned} 6x^2 - x - 2 &= 6x^2 + 3x - 4x - 2 \\ &= 3x(2x + 1) - 2(2x + 1) \\ &= (3x - 2)(2x + 1) \end{aligned}$$

The roots of $6x^2 - x - 2 = 0$ are the values of x for which $(3x - 2)(2x + 1) = 0$

Therefore, $3x - 2 = 0$ or $2x + 1 = 0$,

$$\Rightarrow x = \frac{2}{3} \text{ or } x = -\frac{1}{2}$$

Therefore, the roots of $6x^2 - x - 2 = 0$ are $\frac{2}{3}$ and $-\frac{1}{2}$.

We verify the roots, by substituting $x = \frac{2}{3}$ and $x = -\frac{1}{2}$ in $6x^2 - x - 2 = 0$ and simplifying them.

Example-5. Find the width of the space for spectators discussed in section 5.1.

Solution : In Section 5.1, we found that if the width of the space for spectators is x m, then x satisfies the equation $2x^2 + 45x - 47 = 0$. Applying the factorisation method we write this equation as:-

$$2x^2 - 2x + 47x - 47 = 0$$

$$2x(x - 1) + 47(x - 1) = 0$$

$$\text{i.e., } (x - 1)(2x + 47) = 0$$

So, the roots of the given equation are $x = 1$ or $x = \frac{-47}{2}$.

Since 'x' is the width of space of the spectators it cannot be negative.

Thus, the width is $x = 1$ m. So it is not enough for spectators.



Exercise - 5.2

1. Find the roots of the following quadratic equations by factorisation:

i. $x^2 - 3x - 10 = 0$

ii. $2x^2 + x - 6 = 0$

iii. $\sqrt{2}x^2 + 7x + 5\sqrt{2} = 0$

iv. $2x^2 - x + \frac{1}{8} = 0$

v. $100x^2 - 20x + 1 = 0$

vi. $x(x + 4) = 12$

vii. $3x^2 - 5x + 2 = 0$

viii. $x - \frac{3}{x} = 2$ ($x \neq 0$)

ix. $3(x - 4)^2 - 5(x - 4) = 12$



2. Find two numbers whose sum is 27 and product is 182.
3. Find two consecutive positive integers, sum of whose squares is 613.
4. The altitude of a right triangle is 7 cm less than its base. If the hypotenuse is 13 cm, find the other two sides.
5. A cottage industry produces a certain number of articles in a day. It was observed on a particular day that the cost of production of each article (in rupees) was 3 more than twice the number of articles produced on that day. If the total cost of production on that day was ₹90, find the number of articles produced and the cost of each article.
6. Find the dimensions of a rectangle whose perimeter is 28 meters and whose area is 40 square meters.
7. The base of a triangle is 4cm longer than its altitude. If the area of the triangle is 48 sq.cm then find its base and altitude.
8. Two trains leave a railway station at the same time. The first train travels towards west and the second train towards north. The first train travels 5 km/hr faster than the second train. If after two hours they are 50 km apart, find the average speed of each train.
9. In a class of 60 students, each boy contributed money equal to the number of girls and each girl contributed money equal to the number of boys. If the total money collected was ₹1600, then how many boys were there in the class?
10. A motor boat heads upstream a distance of 24 km in a river whose current is running at 3 km per hour. The trip up and back takes 6 hours. Assuming that the motor boat maintained a constant speed, what was its speed in still water?

5.4 Solution of a Quadratic Equation by Completing the Square

In the previous section, we have learnt method of factorisation for obtaining the roots of a quadratic equation. Is method of factorisation applicable to all types of quadratic equations? Let us try to solve $x^2 + 4x - 4 = 0$ by factorisation method

To solve the given equation $x^2 + 4x - 4 = 0$ by factorisation method.

We have to find 'p' and 'q' such that $p + q = 4$ and $p \times q = -4$

We have no integers p, q satisfying above equation. So by factorisation method it is difficult to solve the given equation. $x^2 + 4x - 4 = 0$

Therefore, we shall try another method.



Consider the following situation

The product of Sunita's age (in years) two years ago and her age four years hence is one more than twice her present age. What is her present age?

To answer this, let her present age be x years. Her age two years ago was $x - 2$ and her age after four years will be $x + 4$.

$$\text{As per given data } (x - 2)(x + 4) = 2x + 1$$

$$\Rightarrow x^2 + 2x - 8 = 2x + 1$$

$$\therefore x^2 - 9 = 0$$

So, the value of ' x ' satisfying the quadratic equation $x^2 - 9 = 0$ will give Sunita's present age. We can write this as $x^2 = 9$. Taking square roots, we get $x = 3$ or $x = -3$. Since the age is a positive number, $x = 3$.

So, Sunita's present age is 3 years.

Now, consider another quadratic equation $(x + 2)^2 - 9 = 0$. To solve it, we can write it as $(x + 2)^2 = 9$. Taking square roots, we get $x + 2 = \sqrt{9} \Rightarrow x + 2 = \pm 3$.

$$\Rightarrow x + 2 = 3 \text{ or } x + 2 = -3.$$

Therefore, $x = 1$ or $x = -5$.

So, the roots of the equation $(x + 2)^2 - 9 = 0$ are 1 and -5 .

In both the examples above, the term containing x is inside a square, and we found the roots easily by taking the square roots. But, what happens if we are asked to solve the equation $x^2 + 4x - 4 = 0$, which cannot be solved by factorisation also.

So, we now introduce the method of completing the square. The idea behind this method is to adjust the left side of the quadratic equation so that it becomes a perfect square of the first degree (linear) polynomial and the RHS without x term.

The process is as follows:

$$x^2 + 4x - 4 = 0$$

$$\Rightarrow x^2 + 4x = 4$$

$$x^2 + 2 \cdot x \cdot 2 = 4$$

Now, the LHS is in the form of $a^2 + 2ab$. If we add b^2 it becomes as $a^2 + 2ab + b^2$ which is perfect square. So, by adding $b^2 = 2^2 = 4$ to both sides we get,

$$x^2 + 2 \cdot x \cdot 2 + 2^2 = 4 + 4$$

$$\Rightarrow (x + 2)^2 = 8 \Rightarrow x + 2 = \pm\sqrt{8}$$

$$\Rightarrow x = -2 \pm 2\sqrt{2}$$



Now consider the equation $3x^2 - 5x + 2 = 0$. Note that the coefficient of x^2 is not 1. So we divide the entire equation by 3 so that the coefficient of x^2 is 1

$$\therefore x^2 - \frac{5}{3}x + \frac{2}{3} = 0$$

$$\Rightarrow x^2 - \frac{5}{3}x = -\frac{2}{3}$$

$$\Rightarrow x^2 - 2 \cdot x \cdot \frac{5}{6} = -\frac{2}{3}$$

$$\Rightarrow x^2 - 2 \cdot x \cdot \frac{5}{6} + \left(\frac{5}{6}\right)^2 = -\frac{2}{3} + \left(\frac{5}{6}\right)^2 \quad \left(\text{add } \left(\frac{5}{6}\right)^2 \text{ both side}\right)$$

$$\left(x - \frac{5}{6}\right)^2 = -\frac{2}{3} + \frac{25}{36}$$

$$\left(x - \frac{5}{6}\right)^2 = \frac{(12 \times -2) + (1 \times 25)}{36}$$

$$\left(x - \frac{5}{6}\right)^2 = \frac{-24 + 25}{36}$$

$$\left(x - \frac{5}{6}\right)^2 = \frac{1}{36}$$

(take square root of both sides)

$$x - \frac{5}{6} = \pm \frac{1}{6}$$

$$\text{So, } x = \frac{5}{6} + \frac{1}{6} \text{ or } x = \frac{5}{6} - \frac{1}{6}$$

$$\text{Therefore, } x = 1 \text{ or } x = \frac{4}{6}$$

$$\text{i.e., } x = 1 \text{ or } x = \frac{2}{3}$$

Therefore, the roots of the given equation are 1 and $\frac{2}{3}$.

From the above examples we can deduce the following algorithm for completing the square.

Algorithm : Let the quadratic equation be $ax^2 + bx + c = 0$ ($a \neq 0$)

Step-1 : Divide each side by 'a'



Step-2 : Rearrange the equation so that constant term c/a is on the right hand side (RHS).

Step-3 : Add $\left[\frac{1}{2}\left(\frac{b}{a}\right)\right]^2$ to both sides to make LHS, a perfect square.

Step-4 : Write the LHS as a square and simplify the RHS.

Step-5 : Solve it.

Example-6. Find the roots of the equation $5x^2 - 6x - 2 = 0$ by the method of completing the square.

Solution : Given : $5x^2 - 6x - 2 = 0$

Now, we follow the Algorithm

Step-1 : $x^2 - \frac{6}{5}x - \frac{2}{5} = 0$ (Dividing both sides by 5)

Step-2 : $x^2 - \frac{6}{5}x = \frac{2}{5}$

Step-3 : $x^2 - \frac{6}{5}x + \left(\frac{3}{5}\right)^2 = \frac{2}{5} + \left(\frac{3}{5}\right)^2$ (Adding $\left(\frac{3}{5}\right)^2$ to both sides)

Step-4 : $\left(x - \frac{3}{5}\right)^2 = \frac{2}{5} + \frac{9}{25}$

Step-5 : $\left(x - \frac{3}{5}\right)^2 = \frac{19}{25}$

$$x - \frac{3}{5} = \pm \sqrt{\frac{19}{25}}$$

$$x = \frac{3}{5} + \frac{\sqrt{19}}{5} \quad \text{or} \quad x = \frac{3}{5} - \frac{\sqrt{19}}{5}$$

$$\therefore x = \frac{3 + \sqrt{19}}{5} \quad \text{or} \quad x = \frac{3 - \sqrt{19}}{5}$$



Example-7. Find the roots of $4x^2 + 3x + 5 = 0$ by the method of completing the square.

Solution : Given $4x^2 + 3x + 5 = 0$

$$x^2 + \frac{3}{4}x + \frac{5}{4} = 0$$

$$x^2 + \frac{3}{4}x = -\frac{5}{4}$$

$$x^2 + \frac{3}{4}x + \left(\frac{3}{8}\right)^2 = -\frac{5}{4} + \left(\frac{3}{8}\right)^2$$

$$\left(x + \frac{3}{8}\right)^2 = -\frac{5}{4} + \frac{9}{64}$$

$$\left(x + \frac{3}{8}\right)^2 = \frac{-71}{64} < 0$$

But $\left(x + \frac{3}{8}\right)^2$ cannot be negative for any real value of x (Why?). So, there is no real value of x satisfying the given equation. Therefore, the given equation has no real roots.



Do This

Solve the equations by completing the square

(i) $x^2 - 10x + 9 = 0$

(ii) $x^2 - 5x + 5 = 0$

(iii) $x^2 + 7x - 6 = 0$

We have solved several examples with the use of the method of ‘completing the square.’ Now, let us apply this method in standard form of quadratic equation $ax^2 + bx + c = 0$ ($a \neq 0$).

Step 1 : Dividing the equation by ‘ a ’ we get ($a \neq 0$)

$$x^2 + \frac{b}{a}x + \frac{c}{a} = 0$$

Step 2 : $x^2 + \frac{b}{a}x = -\frac{c}{a}$

Step 3 : $x^2 + \frac{b}{a}x + \left[\frac{1}{2} \frac{b}{a}\right]^2 = -\frac{c}{a} + \left[\frac{1}{2} \frac{b}{a}\right]^2$

$$\left[\because \text{adding } \left[\frac{1}{2} \frac{b}{a}\right]^2 \text{ both sides} \right]$$



$$\Rightarrow x^2 + 2 \cdot x \frac{b}{2a} + \left[\frac{b}{2a} \right]^2 = -\frac{c}{a} + \left[\frac{b}{2a} \right]^2$$

Step 4: $\left[x + \frac{b}{2a} \right]^2 = \frac{b^2 - 4ac}{4a^2}$

Step 5: If $b^2 - 4ac \geq 0$, then by taking the square roots, we get

$$x + \frac{b}{2a} = \frac{\pm \sqrt{b^2 - 4ac}}{2a}$$

Therefore, $x = \frac{-b \pm \sqrt{b^2 - 4ac}}{2a}$

So, the roots of $ax^2 + bx + c = 0$ are $\frac{-b + \sqrt{b^2 - 4ac}}{2a}$ and $\frac{-b - \sqrt{b^2 - 4ac}}{2a}$,
if $b^2 - 4ac \geq 0$.

If $b^2 - 4ac < 0$, the equation will have no real roots. (Why?)

Thus, if $b^2 - 4ac \geq 0$, then the roots of the quadratic equation $ax^2 + bx + c = 0$ ($a \neq 0$) are

given by $\frac{-b \pm \sqrt{b^2 - 4ac}}{2a}$.

This formula for finding the roots of a quadratic equation is known as the **quadratic formula**.

Let us consider some examples.

Example-8. Solve Q. 2(i) of Exercise 5.1 by using the quadratic formula.

Solution : Let the breadth of the rectangular plot be x metres.

Then the length = $(2x + 1)$ metres.

Since area of rectangular plot is $528m^2$,

we can write $x(2x + 1) = 528$, i.e., $2x^2 + x - 528 = 0$.

This is in the form of $ax^2 + bx + c = 0$, where $a = 2$, $b = 1$, $c = -528$.

So, by the formula



$$x = \frac{-1 \pm \sqrt{1 + 4(2)(528)}}{4} = \frac{-1 \pm \sqrt{4225}}{4} = \frac{-1 \pm 65}{4}$$

$$\therefore x = \frac{64}{4} \text{ or } x = \frac{-66}{4}$$

$$\Rightarrow x = 16 \text{ or } x = -\frac{33}{2}$$

Since breadth cannot be negative. So, the breadth of the plot $x = 16$ metres and hence, the length of the plot is $(2x + 1) = 33$ m.

You should verify that these values satisfy the conditions of the problem.



Think & Discuss

We have three methods to solve a quadratic equation. Among these three, which method would you like to use? Why?

Example-9. Find two consecutive positive odd integers, sum of whose squares is 290.

Solution : Let the first positive odd integer be x . Then, the second integer will be $x + 2$. According to the question,

$$x^2 + (x + 2)^2 = 290$$

$$\text{i.e., } x^2 + x^2 + 4x + 4 = 290$$

$$\text{i.e., } 2x^2 + 4x - 286 = 0$$

$$\text{i.e., } x^2 + 2x - 143 = 0$$

which is a quadratic equation in x .

$$\text{Using the quadratic formula } x = \frac{-b \pm \sqrt{b^2 - 4ac}}{2}$$

$$\text{we get, } x = \frac{-2 \pm \sqrt{4 + 572}}{2} = \frac{-2 \pm \sqrt{576}}{2} = \frac{-2 \pm 24}{2}$$

$$\text{i.e., } x = 11 \text{ or } x = -13$$

But x is given to be positive odd integer. So $x = 11$

$$\therefore x + 2 = 11 + 2 = 13$$

Thus, the two consecutive odd integers are 11 and 13.

$$\text{Check : } 11^2 + 13^2 = 121 + 169 = 290.$$



Example-10. A rectangular park is to be designed whose breadth is 3 m less than its length. Its area is to be 4 square metres more than the area of a park that has already been made in the shape of an isosceles triangle with its base as the breadth of the rectangular park and of altitude 12 m. Find its length and breadth.

Solution : Let the breadth of the rectangular park be x m.

So, its length = $(x + 3)$ m.

Therefore, the area of the rectangular park = $x(x + 3) \text{ m}^2 = (x^2 + 3x) \text{ m}^2$.

Now, base of the isosceles triangle = x m.

Therefore, its area = $\frac{1}{2} \times x \times 12 = 6x \text{ m}^2$.

According to given data

$$x^2 + 3x = 6x + 4$$

i.e., $x^2 - 3x - 4 = 0$

Using the quadratic formula, we get

$$x = \frac{3 \pm \sqrt{25}}{2} = \frac{3 \pm 5}{2} = 4 \text{ or } -1$$

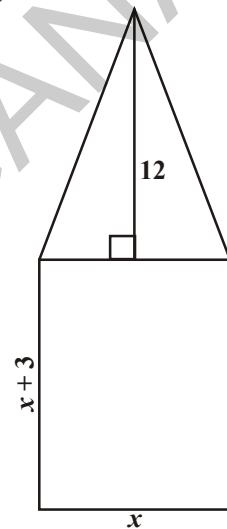
But $x \neq -1$ (Why?). Therefore, $x = 4$.

So, the breadth of the park = 4m and its length will be $x + 3 = 4 + 3 = 7$ m.

Verification : Area of rectangular park = $l \times b = 7\text{m} \times 4\text{m} = 28 \text{ m}^2$,

Similarly, area of triangular park = $\frac{1}{2} \times b \times h = \frac{1}{2} \times 4\text{m} \times 12\text{m} = 24 \text{ m}^2$

Difference between area of rectangular park and triangular park = $(28 - 24) \text{ m}^2 = 4 \text{ m}^2$



Example-11. Find the roots of the following quadratic equations using the formula, if they exist.

(i) $x^2 + 4x + 5 = 0$

(ii) $2x^2 - 2\sqrt{2}x + 1 = 0$

Solution :

(i) $x^2 + 4x + 5 = 0$. Here, $a = 1$, $b = 4$, $c = 5$. So, $b^2 - 4ac = 16 - 20 = -4 < 0$.

Since the square of a real number cannot be negative, therefore $\sqrt{b^2 - 4ac}$ will not have any real value.

So, there are no real roots for the given equation.

(ii) $2x^2 - 2\sqrt{2}x + 1 = 0$. Here, $a = 2$, $b = -2\sqrt{2}$, $c = 1$.



So, $b^2 - 4ac = 8 - 8 = 0$

Therefore, $x = \frac{2\sqrt{2} \pm \sqrt{0}}{4} = \frac{\sqrt{2}}{2} \pm 0$ i.e., $x = \frac{1}{\sqrt{2}}$.

So, the roots are $\frac{1}{\sqrt{2}}, \frac{1}{\sqrt{2}}$.

Example-12. Find the roots of the following equations:

(i) $x + \frac{1}{x} = 3, x \neq 0$

(ii) $\frac{1}{x} - \frac{1}{x-2} = 3, x \neq 0, 2$

Solution :

(i) $x + \frac{1}{x} = 3$. Multiplying both sides of equation by x , we get

$$x^2 + 1 = 3x$$

i.e., $x^2 - 3x + 1 = 0$, which is a quadratic equation.

Here, $a = 1, b = -3, c = 1$

So, $b^2 - 4ac = 9 - 4 = 5 > 0$

Therefore, $x = \frac{3 \pm \sqrt{5}}{2}$ (why?)

So, the roots are $\frac{3 + \sqrt{5}}{2}$ and $\frac{3 - \sqrt{5}}{2}$.

(ii) $\frac{1}{x} - \frac{1}{x-2} = 3, x \neq 0, 2$.

As $x \neq 0, 2$, multiplying the equation by $x(x-2)$, we get

$$(x-2) - x = 3x(x-2)$$

$$= 3x^2 - 6x$$

So, the given equation reduces to $3x^2 - 6x + 2 = 0$, which is a quadratic equation.

Here, $a = 3, b = -6, c = 2$. So, $b^2 - 4ac = 36 - 24 = 12 > 0$

Therefore, $x = \frac{6 \pm \sqrt{12}}{6} = \frac{6 \pm 2\sqrt{3}}{6} = \frac{3 \pm \sqrt{3}}{3}$.

So, the roots are $\frac{3 + \sqrt{3}}{3}$ and $\frac{3 - \sqrt{3}}{3}$.



Example-13. A motor boat whose speed is 18 km/h in still water. It takes 1 hour more to go 24 km upstream than to return downstream to the same spot. Find the speed of the stream.

Solution : Let the speed of the stream be x km/h.

Therefore, the speed of the boat upstream = $(18 - x)$ km/h and the speed of the boat downstream = $(18 + x)$ km/h.

The time taken to go upstream = $\frac{\text{distance}}{\text{speed}} = \frac{24}{18 - x}$ hours.

Similarly, the time taken to go downstream = $\frac{24}{18 + x}$ hours.

According to the question,

$$\frac{24}{18 - x} - \frac{24}{18 + x} = 1$$

i.e., $24(18 + x) - 24(18 - x) = (18 - x)(18 + x)$

i.e., $x^2 + 48x - 324 = 0$

Using the quadratic formula, we get

$$\begin{aligned} x &= \frac{-48 \pm \sqrt{48^2 + 1296}}{2} = \frac{-48 \pm \sqrt{3600}}{2} \\ &= \frac{-48 \pm 60}{2} = 6 \text{ or } -54 \end{aligned}$$

Since x is the speed of the stream, it cannot be negative. So, we ignore the root $x = -54$.

Therefore, $x = 6$ gives the speed of the stream as 6 km/h.



Exercise - 5.3

1. Find the roots of the following quadratic equations, if they exist.

i. $2x^2 + x - 4 = 0$

ii. $4x^2 + 4\sqrt{3}x + 3 = 0$

iii. $5x^2 - 7x - 6 = 0$

iv. $x^2 + 5 = -6x$



2. Find the roots of the quadratic equations given in Q.1 by applying the quadratic formula.
3. Find the roots of the following equations:
 - (i) $x - \frac{1}{x} = 3, x \neq 0$
 - (ii) $\frac{1}{x+4} - \frac{1}{x-7} = \frac{11}{30}, x \neq -4, 7$
4. The sum of the reciprocals of Rehman's ages, (in years) 3 years ago and 5 years from now is $\frac{1}{3}$. Find his present age.
5. In a class test, the sum of Moulika's marks in Mathematics and English is 30. If she got 2 marks more in Mathematics and 3 marks less in English, the product of her marks would have been 210. Find her marks in the two subjects.
6. The diagonal of a rectangular field is 60 metres more than the shorter side. If the longer side is 30 metres more than the shorter side, find the sides of the field.
7. The difference of squares of two numbers is 180. The square of the smaller number is 8 times the larger number. Find the two numbers.
8. A train travels 360 km at a uniform speed. If the speed had been 5 km/h more, it would have taken 1 hour less for the same journey. Find the speed of the train.
9. Two water taps together can fill a tank in $9\frac{3}{8}$ hours. The tap of larger diameter takes 10 hours less than the smaller one to fill the tank separately. Find the time in which each tap can separately fill the tank.
10. An express train takes 1 hour less than a passenger train to travel 132 km between Mysore and Bengaluru (without taking into consideration the time they stop at intermediate stations). If the average speed of the express train is 11 km/h more than that of the passenger train, find the average speed of the two trains.
11. Sum of the areas of two squares is 468 m^2 . If the difference of their perimeters is 24 m, find the sides of the two squares.
12. An object is thrown upwards with an initial velocity of 17 m/sec from a building with a height of 12 m. It is at a height of $S = 12 + 17t - 5t^2$ from the ground after a flight of ' t ' seconds. Find the time taken by the object to touch the ground.
13. If a polygon of ' n ' sides has $\frac{1}{2}n(n-3)$ diagonals. How many sides are there in a polygon with 65 diagonals? Is there a polygon with 50 diagonals?



5.5 Nature of Roots

In the previous section, we have seen that the roots of the equation $ax^2 + bx + c = 0$ are given by

$$x = \frac{-b \pm \sqrt{b^2 - 4ac}}{2a}$$

Now, let us try to study the nature of roots of a quadratic equation.

Case-1 : If $b^2 - 4ac > 0$;

We get two distinct real roots $\frac{-b + \sqrt{b^2 - 4ac}}{2a}$, $\frac{-b - \sqrt{b^2 - 4ac}}{2a}$

Remember that zeroes are those points where value of polynomial becomes zero or we can say that the curve of quadratic polynomial cuts the X-axis.

Similarly, roots of a quadratic equation are those points where the curve cuts the X-axis.

If $b^2 - 4ac > 0$ in such case if we draw corresponding graph for the given quadratic equation we get the following types of figures.

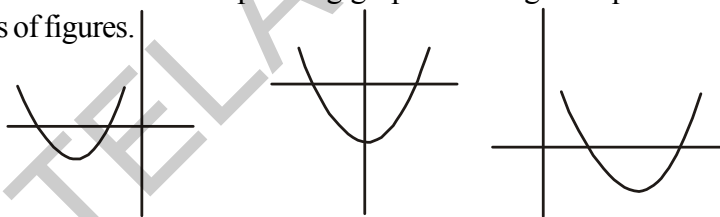


Figure shows that the corresponding curve of the quadratic equation cuts the X-axis at two distinct points

Case-2 : If $b^2 - 4ac = 0$

$$x = \frac{-b + 0}{2a}$$

$$\text{So, } x = \frac{-b}{2a}, \frac{-b}{2a}$$

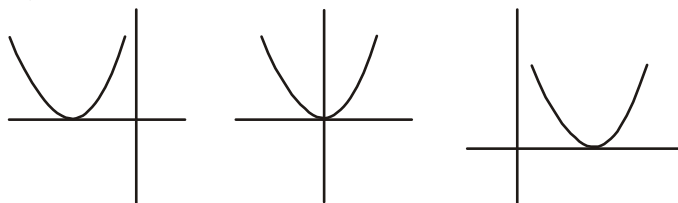
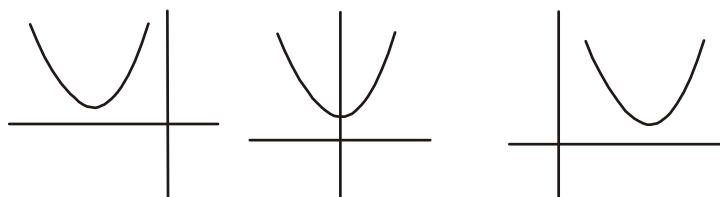


Figure shows that the curve of the quadratic equation touches X-axis at one point.

Case-3 : If $b^2 - 4ac < 0$

There are no real roots. Roots are imaginary.



In this case, the curve neither intersects nor touches the X-axis at all. So, there are no real roots.

Since, $b^2 - 4ac$ determines whether the quadratic equation $ax^2 + bx + c = 0$ ($a \neq 0$) has real roots or not, $b^2 - 4ac$ is called the **discriminant** of the quadratic equation.

So, a quadratic equation $ax^2 + bx + c = 0$ ($a \neq 0$) has

- i. two distinct real roots, if $b^2 - 4ac > 0$,
- ii. two equal real roots, if $b^2 - 4ac = 0$,
- iii. no real roots, if $b^2 - 4ac < 0$.

Let us consider some examples.

Example-14. Find the discriminant of the quadratic equation $2x^2 - 4x + 3 = 0$, and hence find the nature of its roots.

Solution : The given equation is in the form of $ax^2 + bx + c = 0$, where $a = 2$, $b = -4$ and $c = 3$. Therefore, the discriminant

$$b^2 - 4ac = (-4)^2 - (4 \times 2 \times 3) = 16 - 24 = -8 < 0$$

So, the given equation has no real roots.

Example-15. A pole has to be erected at a point on the boundary of a circular park of diameter 13 metres in such a way that the difference of its distances from two diametrically opposite fixed gates A and B on the boundary is 7 metres. Is it possible to do so? If yes, at what distances from the two gates should the pole be erected?

Solution : Let us first draw the diagram.

Let P be the required location of the pole. Let the distance of the pole from the gate B be x m, i.e., $BP = x$ m. Now the difference of the distances of the pole from the two gates = $AP - BP$ (or, $BP - AP$) = 7 m. Therefore, $AP = (x + 7)$ m.

Now, $AB = 13$ m, and since AB is a diameter,

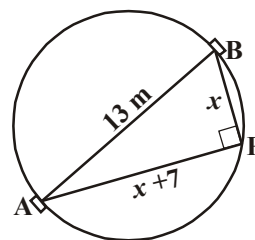
$$\angle BPA = 90^\circ \quad (\text{Why?})$$

Therefore, $AP^2 + PB^2 = AB^2$ (By Pythagoras theorem)

$$\text{i.e.,} \quad (x + 7)^2 + x^2 = 13^2$$

$$\text{i.e.,} \quad x^2 + 14x + 49 + x^2 = 169$$

$$\text{i.e.,} \quad 2x^2 + 14x - 120 = 0$$



So, the value of 'x' satisfying the below equation will become the distance from gate B to pole B.

$$x^2 + 7x - 60 = 0$$

So, it would be possible to place the pole if this equation has real roots. To see if this is so or not, let us consider its discriminant.

$$\therefore \text{Discriminant} = b^2 - 4ac = 7^2 - 4 \times 1 \times (-60) = 289 > 0.$$

So, the given quadratic equation has two real roots, and it is possible to erect the pole on the boundary of the park.

Solving the quadratic equation $x^2 + 7x - 60 = 0$, by the quadratic formula, we get

$$x = \frac{-7 \pm \sqrt{289}}{2} = \frac{-7 \pm 17}{2}$$

Therefore, $x = 5$ or -12 .

Since x is the distance between the pole and the gate B, it must be positive.

Therefore, $x = -12$ will have to be ignored. So, $x = 5$.

Thus, the pole has to be erected on the boundary of the park at a distance of 5m from the gate B and 12m from the gate A.



Try This

1. Explain the benefits of evaluating the discriminant of a quadratic equation before attempting to solve it. What does its value signify?
2. Write three quadratic equations, one having two distinct real solutions, one having no real solution and one having exactly one real solution.

Example-16. Find the discriminant of the equation $3x^2 - 2x + \frac{1}{3} = 0$ and hence find the nature of its roots. Find them, if they are real.

Solution : Here $a = 3$, $b = -2$ and $c = \frac{1}{3}$

$$\text{Therefore, discriminant } b^2 - 4ac = (-2)^2 - 4 \times 3 \times \frac{1}{3} = 4 - 4 = 0.$$

Hence, the given quadratic equation has two equal real roots.

$$\text{The roots are } \frac{-b}{2a}, \frac{-b}{2a}, \text{ i.e., } \frac{2}{6}, \frac{2}{6}, \text{ i.e., } \frac{1}{3}, \frac{1}{3}.$$





Exercise - 5.4

- Find the nature of the roots of the following quadratic equations. If real roots exist, find them:
 - $2x^2 - 3x + 5 = 0$
 - $3x^2 - 4\sqrt{3}x + 4 = 0$
 - $2x^2 - 6x + 3 = 0$
- Find the values of k for each of the following quadratic equations, so that they have two equal roots.
 - $2x^2 + kx + 3 = 0$
 - $kx(x - 2) + 6 = 0$ ($k \neq 0$)
- Is it possible to design a rectangular mango grove whose length is twice its breadth, and the area is 800 m^2 ? If so, find its length and breadth.
- The sum of the ages of two friends is 20 years. Four years ago, the product of their ages in years was 48. Is the above situation possible? If so, determine their present ages.
- Is it possible to design a rectangular park of perimeter 80 m and area 400 m^2 ? If so, find its length and breadth. Comment on your answer.



Optional Exercise [For extensive Learning]

- Some points are plotted on a plane such that any three of them are non collinear. Each point is joined with all remaining points by line segments. Find the number of points if the number of line segments are 10.
- A two digit number is such that the product of its digits is 8. When 18 is added to the number the digits interchange their places. Determine the number.
- A piece of wire 8 m. in length is cut into two pieces, and each piece is bent into a square. Where should the cut in the wire be made if the sum of the areas of these squares is to be 2 m^2 ?

$$\left[\text{Hint : } x + y = 8, \left(\frac{x}{4}\right)^2 + \left(\frac{y}{4}\right)^2 = 2 \Rightarrow \left(\frac{x}{4}\right)^2 + \left(\frac{8-x}{4}\right)^2 = 2 \right].$$

- Vinay and Praveen working together can paint the exterior of a house in 6 days. Vinay by himself can complete the job in 5 days less than Praveen. How long will it take Vinay to complete the job by himself?
- Show that the sum of roots of a quadratic equation $ax^2 + bx + c = 0$ ($a \neq 0$) is $-\frac{b}{a}$.



6. Show that the product of the roots of a quadratic equation $ax^2 + bx + c = 0$ ($a \neq 0$) is $\frac{c}{a}$.
7. If the sum of the fraction and its reciprocal is $2\frac{16}{21}$, find the fraction.

Suggested Projects

Solving quadratic equations by graphical methods.

- Take two or three quadratic equations of the form $ax^2 + bx + c = 0$, where $a \neq 0$, for different situations like $a > 0$, $a < 0$, $b = 0$ and solve them by graphical methods.



What We Have Discussed

- Standard form of quadratic equation in variable x is $ax^2 + bx + c = 0$, where a, b, c are real numbers and $a \neq 0$.
- A real number α is said to be a root of the quadratic equation $ax^2 + bx + c = 0$, if $a\alpha^2 + b\alpha + c = 0$.
- If we can factorise $ax^2 + bx + c, a \neq 0$, into a product of two linear factors, then the roots of the quadratic equation $ax^2 + bx + c = 0$ can be found by equating each factor to zero.
- A quadratic equation can also be solved by the method of completing the square.
- Quadratic formula: The roots of a quadratic equation $ax^2 + bx + c = 0$ ($a \neq 0$) are given by

$$\frac{-b \pm \sqrt{b^2 - 4ac}}{2a}, \text{ provided } b^2 - 4ac \geq 0.$$
- A quadratic equation $ax^2 + bx + c = 0$ ($a \neq 0$) has
 - two distinct real roots, if $b^2 - 4ac > 0$,
 - two equal roots, if $b^2 - 4ac = 0$, and
 - no real roots, if $b^2 - 4ac < 0$.





6.1 Introduction

You might have observed that in nature, many things follow a certain pattern such as the petals of a sunflower, the cells of a honeycomb, the grains on a maize cob, the spirals on a pineapple and on a pine cone etc.

Can you see a pattern in each of the above given example? We can see the natural patterns have a repetition which is not progressive. The identical petals of the sunflower are equidistantly grown. In a honeycomb identical hexagonal shaped cells are arranged symmetrically around each hexagonal cell. Similarly, you can find out other natural patterns in spirals of pineapple....

You can look for some other patterns in nature. Some examples are:

- (i) List of the last digits (digits in unit place) taken from the values of $4, 4^2, 4^3, 4^4, 4^5, 4^6, \dots$ is 4, 6, 4, 6, 4, 6,
- (ii) Mary is doing problems on patterns as a part of preparing for a bank exam. One of them is “find the next two terms in the following pattern”.
1, 2, 4, 8, 10, 20, 22
- (iii) Usha applied for a job and got selected. She has been offered a job with a starting monthly salary of ₹8000, with an annual increment of ₹500. Her salary (in rupees) for 1st, 2nd, 3rd ... years will be 8000, 8500, 9000 respectively.
- (iv) The lengths of the rungs of a ladder decrease uniformly by 2 cm from bottom to top. The bottom rung is 45 cm in length. The lengths (in cm) of the 1st, 2nd, 3rd, 8th rung from the bottom to the top are 45, 43, 41, 39, 37, 35, 33, 31 respectively.

Can you see any relationship between the terms in the pattern of numbers written above?

Pattern given in example (i) has a repetitive pattern where 4 and 6 are repeating alternatively.



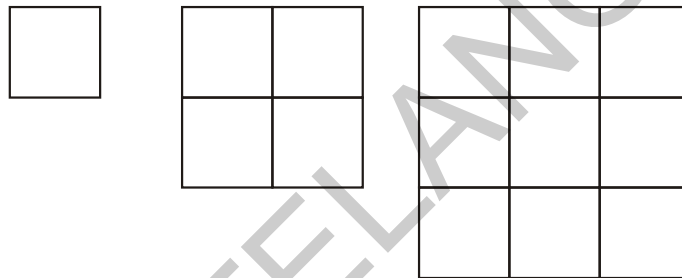
Now try to find out the pattern in example (ii). In examples (iii) and (iv), the relationship between the numbers in each list is constantly progressive. In the given list 8000, 8500, 9000, each succeeding term is obtained by adding 500 to the preceding term.

Where as in 45, 43, 41, each succeeding term is obtained by adding '-2' to each preceding term. Now we can see some more examples of progressive patterns.

- (a) In a savings scheme, the amount becomes $\frac{5}{4}$ times of itself after 3 years.

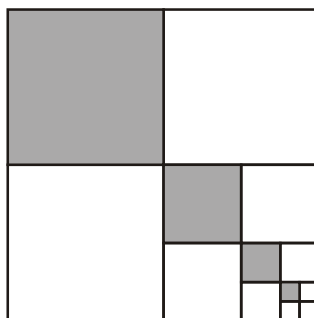
The maturity amount (in Rupees) of an investment of ₹ 8000 after 3, 6, 9 and 12 years will be 10000, 12500, 15625, 19531.25 respectively.

- (b) The number of unit squares in squares with sides 1, 2, 3, units are respectively, $1^2, 2^2, 3^2, \dots$



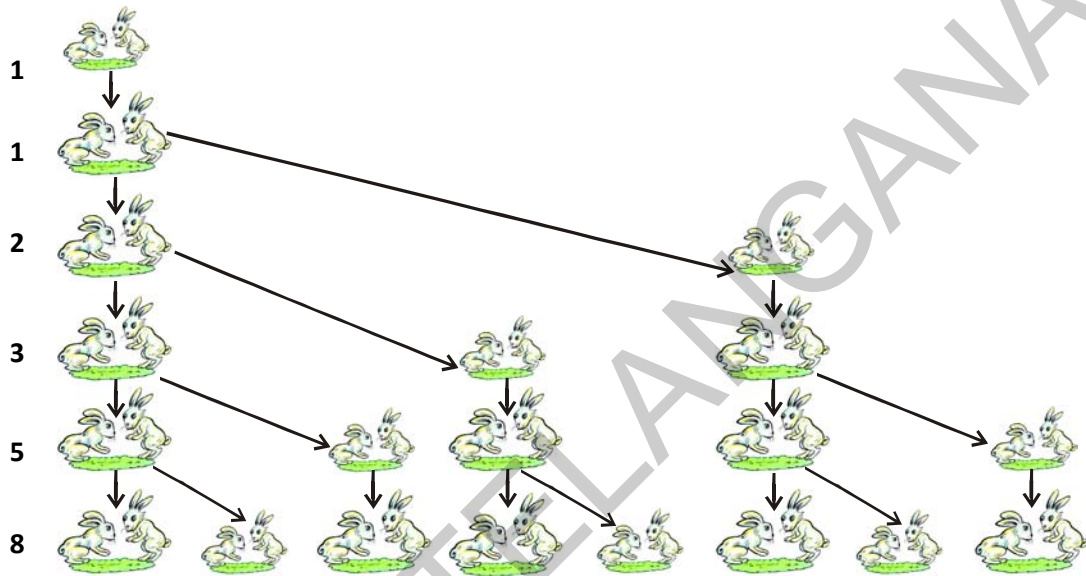
- (c) Hema put ₹ 1000 into her daughter's money box when she was one year old and increased the amount by ₹ 500 every year. The amount of money (in ₹) in the box on her 1st, 2nd, 3rd, 4th birthday would be 1000, 1500, 2000, 2500, respectively.
- (d) The fraction of first, second, third shaded regions of the squares in the following figure will be respectively.

$$\frac{1}{4}, \frac{1}{16}, \frac{1}{64}, \frac{1}{256}, \dots$$



- (e) A pair of rabbits are too young to produce in their first month. In the second, and every subsequent month, they produce a new pair. Each new pair of rabbits produce a new pair in their second month and in every subsequent month (see the figure below). Assuming no rabbit dies, the number of pairs of rabbits at the start of the 1st, 2nd, 3rd,, 6th month, respectively are :

1, 1, 2, 3, 5, 8



In the examples above, we observe some patterns. In some of them, we find that the succeeding terms are obtained by **adding a fixed number** and in others **by multiplying with a fixed number**. In another, we find that they are squares of consecutive numbers and so on.

In this chapter, we shall discuss some of these patterns in which succeeding terms are obtained by adding a fixed number to the preceding term or multiplying the preceding term by a fixed number. These patterns are called as arithmetic and geometric progressions respectively. We shall also see how to find their n^{th} term and the sum of n consecutive terms for a general value of ' n ' and use this knowledge in solving some daily life problems.

History : Evidence is found that by 400 BCE, Babylonians knew of Arithmetic and geometric progressions. According to Boethius (570 CE), these progressions were known to early Greek writers. Among the Indian mathematicians, Aryabhatta (470 CE) was the first to give formula for the sum of squares and cubes of natural numbers in his famous work Aryabhatiyam written around 499 CE. He also gave the formula for finding the sum of n terms of an Arithmetic Progression starting with p^{th} term. Indian mathematician Brahmagupta (598 CE), Mahavira (850 CE) and Bhaskara (1114-1185 CE) also considered the sums of squares and cubes.



Let us see some more examples of A.P. :

- Heights (in cm) of some students of a school standing in a queue in the morning assembly are 147 , 148, 149, . . . , 157.
- Minimum temperatures (in degree celsius) recorded for a week, in the month of January in a city, arranged in ascending order are
 $- 3.1, - 3.0, - 2.9, - 2.8, - 2.7, - 2.6, - 2.5$
- The balance money (in ₹) after paying 5% of the total loan of ₹1000 every month is ₹950, ₹900, ₹850, ₹800, . . . , ₹50.
- Cash prizes (in ₹) given by a school to the toppers of Classes I to XII are ₹200, ₹250, ₹300, ₹350, . . . , ₹750 respectively.
- Total savings (in ₹) after every month, for 10 months when ₹ 50 are saved each month are ₹50, ₹100, ₹150, ₹200, ₹250, ₹300, ₹350, ₹400, ₹450, ₹500.



Think and Discuss

- Think how each of the list given above form an A.P.. Discuss with your friends.
- Find the common difference in each pattern above? Think when is it positive?
- Write an arithmetic progression in which the common difference is a small positive quantity.
- Make an A.P. in which the common difference is big(large) positive quantity.
- Make an A.P. in which the common difference is negative.

General form of an A.P. : An A.P. can be written as

$$a, a + d, a + 2d, a + 3d, \dots$$

This is called general form of an A.P where 'a' is the first term and 'd' is the common difference

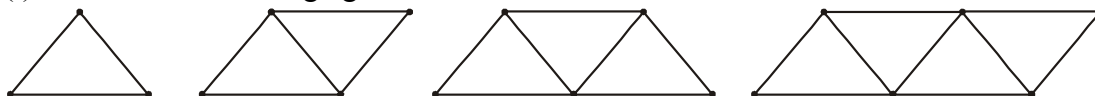
For example in 1, 2, 3, 4, 5, The first term is 1 and the common difference is also 1.

In 2, 4, 6, 8, 10, what is the first term and what is the common difference?



Activity

- (i) Make the following figures with match sticks



- (ii) Write down the number of match sticks required for each figure.



- (iii) Can you find a common difference in members of the list? Is it a constant?
- (iv) Does the list of these numbers form an A.P.?

6.2.2 Parameters of Arithmetic Progressions

Note that in examples (a) to (e) above, in section 6.2.1 there are only a finite number of terms. Such an A.P. is called a **finite A.P.** Also note that each of these Arithmetic Progressions (A.P.s) has a last term. The A.P.s in examples (i) to (v) in the section 6.2, are not finite A.P.s and so they are called **infinite Arithmetic Progressions**. Such A.P.s are never ending and do not have a last term.



Do this

Write three examples for finite A.P. and three for infinite A.P..

Now, to know about an A.P., what is the minimum information that you need? Is it enough to know the first term? Or, is it enough to know only the common difference?

We can see that we need to know both – the first term a and the common difference d . These two parameters are sufficient for us to complete the Arithmetic Progression.

For instance, if the first term a is 6 and the common difference d is 3, then the A.P. is

$$6, 9, 12, 15, \dots$$

and if a is 6 and d is -3 , then the A.P. is

$$6, 3, 0, -3, \dots$$

Similarly, when

$$a = -7, \quad d = -2, \quad \text{the A.P. is } -7, -9, -11, -13, \dots$$

$$a = 1.0, \quad d = 0.1, \quad \text{the A.P. is } 1.0, 1.1, 1.2, 1.3, \dots$$

$$a = 0, \quad d = 1\frac{1}{2}, \quad \text{the A.P. is } 0, 1\frac{1}{2}, 3, 4\frac{1}{2}, 6, \dots$$

$$a = 2, \quad d = 0, \quad \text{the A.P. is } 2, 2, 2, 2, \dots$$

So, if you know what a and d are, you can list the A.P..

Let us try the other way. If you are given a list of numbers, how can you say whether it is an A.P. or not?

For example, for any list of numbers :

$$6, 9, 12, 15, \dots,$$

We check the difference of the succeeding terms.



In the given list we have $a_2 - a_1 = 9 - 6 = 3$,

Similarly $a_3 - a_2 = 12 - 9 = 3$,

$$a_4 - a_3 = 15 - 12 = 3$$

We see that $a_2 - a_1 = a_3 - a_2 = a_4 - a_3 \dots = 3$

Here, the difference of any two consecutive terms in each case is 3. So, the given list is an A.P. whose first term $a = 6$ and common difference $d = 3$.

For the list of numbers : 6, 3, 0, -3, ... ,

$$a_2 - a_1 = 3 - 6 = -3,$$

$$a_3 - a_2 = 0 - 3 = -3$$

$$a_4 - a_3 = -3 - 0 = -3$$

$$a_2 - a_1 = a_3 - a_2 = a_4 - a_3 = -3$$

Similarly, this is also an A.P. whose first term $a = 6$ and the common difference $d = -3$.

So, we see that if the difference between any two consecutive terms is constant, then it is an Arithmetic Progression.

In general, for an A.P. a_1, a_2, \dots, a_n , we can say

$$d = a_{k+1} - a_k \quad \text{where } k \in \mathbb{N}; k \geq 1$$

where a_{k+1} and a_k are the $(k+1)^{\text{th}}$ and the k^{th} terms respectively.

Consider the list of numbers 1, 1, 2, 3, 5, By looking at it, you can tell that the difference between any two consecutive terms is not the same. So, this is not an A.P..

Note : To find d in the A.P. : 6, 3, 0, -3, ... , we have subtracted 6 from 3 and not 3 from 6. We have to subtract the k^{th} term from the $(k+1)^{\text{th}}$ term even if the $(k+1)^{\text{th}}$ term is smaller and to find 'd' in a given A.P., we do not need to find all of $a_2 - a_1, a_3 - a_2 \dots$. It is enough to find only one of them



Do This

1. Take any Arithmetic Progression.
2. Add a fixed number to each and every term of A.P.. Write the resulting numbers as a list.
3. Similarly subtract a fixed number from each and every term of A.P.. Write the resulting numbers as a list.
4. Multiply or divide each term of A.P. by a fixed number and write the resulting numbers as a list.



5. Check whether the resulting lists are A.P. in each case.
6. What is your conclusion?

Let us consider some examples

Example-1. For the A.P. : $\frac{1}{4}, \frac{-1}{4}, \frac{-3}{4}, \frac{-5}{4}$, write the first term a and the common difference d .

Solution : Here, $a = \frac{1}{4}$; $d = \frac{-1}{4} - \frac{1}{4} = \frac{-1}{2}$

Remember that we can find d using any two consecutive terms, once we know that the numbers are in A.P..

Example-2. Which of the following forms an A.P.? If they form an A.P., then write the next two terms?

- (i) 4, 10, 16, 22, ... (ii) 1, -1, -3, -5, ... (iii) -2, 2, -2, 2, -2, ...
 (iv) 1, 1, 1, 2, 2, 2, 3, 3, 3, ... (v) $x, 2x, 3x, 4x$

Solution : (i) We have $a_2 - a_1 = 10 - 4 = 6$

$$a_3 - a_2 = 16 - 10 = 6$$

$$a_4 - a_3 = 22 - 16 = 6$$

i.e., $a_{k+1} - a_k$ is same every time.

So, the given list of numbers forms an A.P. with the common difference $d = 6$.

The next two terms are: $22 + 6 = 28$ and $28 + 6 = 34$.

(ii) $a_2 - a_1 = -1 - 1 = -2$

$$a_3 - a_2 = -3 - (-1) = -3 + 1 = -2$$

$$a_4 - a_3 = -5 - (-3) = -5 + 3 = -2$$

i.e., $a_{k+1} - a_k$ is same every time.

So, the given list of numbers forms an A.P. with the common difference $d = -2$.

The next two terms are:

$$-5 + (-2) = -7 \text{ and } -7 + (-2) = -9$$



$$(iii) a_2 - a_1 = 2 - (-2) = 2 + 2 = 4$$

$$a_3 - a_2 = -2 - 2 = -4$$

As $a_2 - a_1 \neq a_3 - a_2$, the given list of numbers does not form an A.P..

$$(iv) a_2 - a_1 = 1 - 1 = 0$$

$$a_3 - a_2 = 1 - 1 = 0$$

$$a_4 - a_3 = 2 - 1 = 1$$

Here, $a_2 - a_1 = a_3 - a_2 \neq a_4 - a_3$.

So, the given list of numbers does not form an A.P..

$$(v) \text{ We have } a_2 - a_1 = 2x - x = x$$

$$a_3 - a_2 = 3x - 2x = x$$

$$a_4 - a_3 = 4x - 3x = x$$

i.e., $a_{k+1} - a_k$ is same every time. So, the given list form an A.P..

The next two terms are $4x + x = 5x$ and $5x + x = 6x$.



Exercise - 6.1

1. In which of the following situations, the list of numbers involved forms an arithmetic progression? why?

(i) The minimum taxi fare is ₹ 20 for the first km and there after ₹ 8 for each additional km.

(ii) The amount of air present in a cylinder when a vacuum pump removes $\frac{1}{4}$ of the air remaining in the cylinder at a time.

(iii) The cost of digging a well, after every metre of digging, when it costs ₹ 150 for the first metre and rises by ₹ 50 for each subsequent metre.

(iv) The amount of money in the account at the end of each year, when ₹ 10000 is deposited at compound interest at 8 % per annum.

2. Write first four terms of the A.P., when the first term a and the common difference d are given as follows:

$$(i) a = 10, d = 10$$

$$(ii) a = -2, d = 0$$

$$(iii) a = 4, d = -3$$

$$(iv) a = -1, d = \frac{1}{2}$$

$$(v) a = -1.25, d = -0.25$$



3. For the following A.P.s, write the first term and the common difference:

(i) $3, 1, -1, -3, \dots$

(ii) $-5, -1, 3, 7, \dots$

(iii) $\frac{1}{3}, \frac{5}{3}, \frac{9}{3}, \frac{13}{3}, \dots$

(iv) $0.6, 1.7, 2.8, 3.9, \dots$

4. Which of the following are A.P.s? If they form an A.P., find the common difference d and write the next three terms.

(i) $2, 4, 8, 16, \dots$

(ii) $2, \frac{5}{2}, 3, \frac{7}{2}, \dots$

(iii) $-1.2, -3.2, -5.2, -7.2, \dots$

(iv) $-10, -6, -2, 2, \dots$

(v) $3, 3 + \sqrt{2}, 3 + 2\sqrt{2}, 3 + 3\sqrt{2}, \dots$

(vi) $0.2, 0.22, 0.222, 0.2222, \dots$

(vii) $0, -4, -8, -12, \dots$

(viii) $-\frac{1}{2}, -\frac{1}{2}, -\frac{1}{2}, -\frac{1}{2}, \dots$

(ix) $1, 3, 9, 27, \dots$

(x) $a, 2a, 3a, 4a, \dots$

(xi) a, a^2, a^3, a^4, \dots

(xii) $\sqrt{2}, \sqrt{8}, \sqrt{18}, \sqrt{32}, \dots$

(xiii) $\sqrt{3}, \sqrt{6}, \sqrt{9}, \sqrt{12}, \dots$

6.3 n^{th} Term of an Arithmetic Progression

Usha who applied for a job and got selected. Let us consider the offer made to her. She has been offered a starting monthly salary of ₹ 8000, with an annual increment of ₹ 500. What would be her monthly salary in the fifth year?

To answer this, let us first see what her monthly salary for the second year would be.

It would be ₹ $(8000 + 500) = ₹ 8500$.

In the same way, we can find the monthly salary for the 3rd, 4th and 5th year by adding ₹ 500 to the salary of the previous year.

So, the salary for the 3rd year = ₹ $(8500 + 500)$

$$= ₹ (8000 + 500 + 500)$$

$$= ₹ (8000 + 2 \times 500)$$

$$= ₹ [8000 + (3 - 1) \times 500] \quad (\text{for the } 3^{\text{rd}} \text{ year})$$

$$= ₹ 9000$$

Salary for the 4th year = ₹ $(9000 + 500)$

$$= ₹ (8000 + 500 + 500 + 500)$$



$$\begin{aligned}
 &= ₹ (8000 + 3 \times 500) \\
 &= ₹ [8000 + (4 - 1) \times 500] \quad (\text{for the 4}^{\text{th}} \text{ year}) \\
 &= ₹ 9500
 \end{aligned}$$

$$\begin{aligned}
 \text{Salary for the 5}^{\text{th}} \text{ year} &= ₹ (9500 + 500) \\
 &= ₹ (8000 + 500 + 500 + 500 + 500) \\
 &= ₹ (8000 + 4 \times 500) \\
 &= ₹ [8000 + (5 - 1) \times 500] \quad (\text{for the 5}^{\text{th}} \text{ year}) \\
 &= ₹ 10000
 \end{aligned}$$

Observe that we are getting a list of numbers

$$8000, 8500, 9000, 9500, 10000, \dots$$

These numbers are in Arithmetic Progression.

Looking at the pattern above, can we find her monthly salary in the 6th year? The 15th year? And, assuming that she is still working at the same job, what would be her monthly salary in the 25th year? Here, we can calculate the salary of the present year by adding ₹ 500 to the salary of previous year. Can we make this process shorter? Let us see. You may have already got some idea from the way we have obtained the salaries above.

$$\begin{aligned}
 \text{Salary for the 15}^{\text{th}} \text{ year} &= \text{Salary for the 14}^{\text{th}} \text{ year} + ₹ 500 \\
 &= ₹ \left[8000 + \underbrace{500 + 500 + 500 + \dots + 500}_{13 \text{ times}} \right] + ₹ 500 \\
 &= ₹ [8000 + 14 \times 500] \\
 &= ₹ [8000 + (15 - 1) \times 500] = ₹ 15000
 \end{aligned}$$

i.e., First salary + (15 - 1) × Annual increment.

In the same way, her monthly salary for the 25th year would be

$$\begin{aligned}
 &₹ [8000 + (25 - 1) \times 500] = ₹ 20000 \\
 &= \text{First salary} + (25 - 1) \times \text{Annual increment}
 \end{aligned}$$

This example has given us an idea about how to write the 15th term, or the 25th term. By using the same idea, now let us find the n^{th} term of an A.P..

Let a_1, a_2, a_3, \dots be an A.P. whose first term a_1 is a and the common difference is d .



Then,

$$\text{the second term } a_2 = a + d = a + (2 - 1) d$$

$$\text{the third term } a_3 = a_2 + d = (a + d) + d = a + 2d = a + (3 - 1) d$$

$$\text{the fourth term } a_4 = a_3 + d = (a + 2d) + d = a + 3d = a + (4 - 1) d$$

.....
.....

Looking at the pattern, we can say that the n^{th} term $a_n = a + (n - 1) d$.

So, the n^{th} term of an A.P. with first term a and common difference d is given by $a_n = a + (n - 1) d$.

a_n is also called the **general term of the A.P.**

If there are m terms in the A.P., then a_m represents the **last term which is sometimes also denoted by l .**

Finding terms of an A.P. : Using the above formula we can find different terms of an arithmetic progression.

Let us consider some examples.

Example-3. Find the 10th term of the A.P. : 5, 1, -3, -7 ...

Solution : Here, $a = 5$, $d = 1 - 5 = -4$ and $n = 10$.

$$\text{We have } a_n = a + (n - 1) d$$

$$\text{So, } a_{10} = 5 + (10 - 1) (-4) = 5 - 36 = -31$$

Therefore, the 10th term of the given A.P. is -31.

Example-4. Which term of the A.P. : 21, 18, 15, ... is -81?

Is zero a term of this A.P.? Give reason for your answer.

Solution : Here, $a = 21$, $d = 18 - 21 = -3$ and if $a_n = -81$, we have to find n .

$$\begin{aligned} \text{As } a_n &= a + (n - 1) d, \\ \text{we have } -81 &= 21 + (n - 1)(-3) \\ -81 &= 24 - 3n \\ -105 &= -3n \end{aligned}$$

$$\text{So, } n = 35$$

Therefore, the 35th term of the given A.P. is -81.

Next, we want to know if there is any n for which $a_n = 0$. If such n is there, then

$$\begin{aligned} 21 + (n - 1)(-3) &= 0, \\ \text{i.e., } 3(n - 1) &= 21 \\ \text{i.e., } n &= 8 \end{aligned}$$

So, the eighth term is zero.



Example-5. Determine the A.P. whose 3rd term is 5 and the 7th term is 9.

Solution : We have

$$a_3 = a + (3 - 1) d = a + 2d = 5 \quad (1)$$

and $a_7 = a + (7 - 1) d = a + 6d = 9 \quad (2)$

Solving the pair of linear equations (1) and (2), we get

$$a = 3, d = 1$$

Hence, the required A.P. is 3, 4, 5, 6, 7, ...

Example-6. Check whether 301 is a term of the list of numbers 5, 11, 17, 23, ...

Solution : We have :

$$a_2 - a_1 = 11 - 5 = 6, a_3 - a_2 = 17 - 11 = 6, a_4 - a_3 = 23 - 17 = 6$$

As $(a_{k+1} - a_k)$ is the same for $k = 1, 2, 3$, etc., the given list of numbers is an A.P.

Now, for this A.P. we have $a = 5$ and $d = 6$.

We choose to begin with the assumption that 301 is n th term of this A.P.. We will see if an 'n' exists for which $a_n = 301$.

We know

$$a_n = a + (n - 1) d$$

$$301 = 5 + (n - 1) \times 6$$

or $301 = 6n - 1$

So, $n = \frac{302}{6} = \frac{151}{3}$

But n should be a positive integer (Why?).

So, 301 is not a term of the given list of numbers.

Example-7. How many two-digit numbers are divisible by 3?

Solution : The list of two-digit numbers divisible by 3 is :

$$12, 15, 18, \dots, 99$$

Is this an A.P. ? Yes it is. Here, $a = 12, d = 3, a_n = 99$.



As $a_n = a + (n - 1) d$,
 we have $99 = 12 + (n - 1) \times 3$
 i.e., $87 = (n - 1) \times 3$
 i.e., $n - 1 = \frac{87}{3} = 29$
 i.e., $n = 29 + 1 = 30$ (So, 99 is the 30th term)



So, there are 30 two-digit numbers divisible by 3.

Example-8. Find the 11th term from the last of the A.P. series given below :

A.P. : 10, 7, 4, . . . , - 62.

Solution : Here, $a = 10$, $d = 7 - 10 = -3$, $l = -62$,

To find the 11th term from the last term, we will find the total number of terms in the A.P.

where $l = a + (n - 1) d$
 So, $-62 = 10 + (n - 1)(-3)$
 i.e., $-72 = (n - 1)(-3)$
 i.e., $n - 1 = 24$
 or $n = 25$

So, there are 25 terms in the given A.P.

The 11th term from the last will be the 15th term of the A.P. (Note that it will not be the 14th term. Why?)

So, $a_{15} = 10 + (15 - 1)(-3) = 10 - 42 = -32$

i.e., the 11th term from the end is - 32.

Note : The 11th term from the last is also equal to 11th term of the A.P. with first term - 62 and the common difference 3.

Example-9. A sum of ₹ 1000 is invested at 8% simple interest per year. Calculate the interest at the end of each year. Do these interests form an A.P.? If so, find the interest at the end of 30 years.

Solution : We know that the formula to calculate simple interest is given by

$$\text{Simple Interest} = \frac{P \times R \times T}{100}$$

So, the interest at the end of the 1st year = ₹ $\frac{1000 \times 8 \times 1}{100} = ₹ 80$

The interest at the end of the 2nd year = ₹ $\frac{1000 \times 8 \times 2}{100} = ₹ 160$



The interest at the end of the 3rd year = $\frac{1000 \times 8 \times 3}{100} = ₹ 240$

Similarly, we can obtain the interest at the end of the 4th year, 5th year, and so on. So, the interest (in Rupees) at the end of the 1st, 2nd, 3rd, ... years, respectively are

$$80, 160, 240, \dots$$

It is an A.P. and the difference between the consecutive terms in the list is 80,

i.e., $d = 80$. Also, $a = 80$.

So, to find the interest at the end of 30 years, we shall find a_{30} .

Now, $a_{30} = a + (30 - 1)d = 80 + 29 \times 80 = 2400$

So, the interest at the end of 30 years will be ₹ 2400.

Example-10. In a flower bed, there are 23 rose plants in the first row, 21 in the second, 19 in the third, and so on. There are 5 rose plants in the last row. How many rows are there in the flower bed?

Solution : The number of rose plants in the 1st, 2nd, 3rd, ..., rows are 23, 21, 19, ..., 5

It forms an A.P. (Why?).

Let the number of rows in the flower bed be n .

Then $a = 23$, $d = 21 - 23 = -2$, $a_n = 5$

As, $a_n = a + (n - 1)d$

We have, $5 = 23 + (n - 1)(-2)$

i.e., $-18 = (n - 1)(-2)$ i.e., $n = 10$

The rows in the flower bed = 10.



Exercise - 6.2

- Fill in the blanks in the following table, given that a is the first term, d the common difference and a_n the n th term of the A.P.:

S. No.	a	d	n	a_n
(i)	7	3	8	...
(ii)	-18	...	10	0



(iii)	...	-3	18	-5
(iv)	-18.9	2.5	...	3.6
(v)	3.5	0	105	...

2. Find the
 - (i) 30th term of the A.P. 10, 7, 4
 - (ii) 11th term of the A.P. : $-3, \frac{-1}{2}, 2, \dots$
3. Find the respective terms for the following A.P.s.
 - (i) $a_1 = 2, a_3 = 26$ find a_2
 - (ii) $a_2 = 13, a_4 = 3$ find a_1, a_3
 - (iii) $a_1 = 5, a_4 = 9\frac{1}{2}$ find a_2, a_3
 - (iv) $a_1 = -4, a_6 = 6$ find a_2, a_3, a_4, a_5
 - (v) $a_2 = 38, a_6 = -22$ find a_1, a_3, a_4, a_5
4. Which term of the A.P. : 3, 8, 13, 18, ... , is 78?
5. Find the number of terms in each of the following A.P.s :
 - (i) 7, 13, 19, ... , 205
 - (ii) $18, 15\frac{1}{2}, 13, \dots, -47$
6. Check whether, -150 is a term of the A.P. : 11, 8, 5, 2 ...
7. Find the 31st term of an A.P. whose 11th term is 38 and the 16th term is 73.
8. If the 3rd and the 9th terms of an A.P. are 4 and -8 respectively, which term of this A.P. is zero?
9. The 17th term of an A.P. exceeds its 10th term by 7. Find the common difference.
10. Two A.P.s have the same common difference. The difference between their 100th terms is 100. What is the difference between their 1000th terms?
11. How many three-digit numbers are divisible by 7?
12. How many multiples of 4 lie between 10 and 250?
13. For what value of n , are the n th terms of two A.P.s: 63, 65, 67, ... and 3, 10, 17, ... equal?
14. Determine the A.P. whose 3rd term is 16 and the 7th term exceeds the 5th term by 12.
15. Find the 20th term from the end of the A.P. : 3, 8, 13, ... , 253.



16. The sum of the 4th and 8th terms of an A.P. is 24 and the sum of the 6th and 10th terms is 44. Find the first three terms of the A.P.
17. Subba Rao started his job in 1995 at a monthly salary of ₹ 5000 and received an increment of ₹ 200 each year. In which year did his salary reach ₹ 7000?

6.4 Sum of First n Terms in Arithmetic Progression

Let us consider the situation again given in Section 6.1 in which Hema put ₹ 1000 in the money box when her daughter was one year old, ₹ 1500 on her second birthday, ₹ 2000 on her third birthday and will continue in the same way. How much money will be collected in the money box by the time her daughter is 21 years old?

Here, the amount of money (in Rupees) put in the money box on her first, second, third, fourth . . . birthday were respectively ₹1000, ₹1500, ₹2000, ₹2500, . . . till her 21st birthday. To find the total amount in the money box on her 21st birthday, we will have to write each of the 21 numbers in the list above and then add them up. Don't you think it would be a tedious and time consuming process? Can we make the process shorter?

This would be possible if we can find a method for getting this sum. Let us see.



6.4.1 How 'Gauss' found the sum of terms

We consider the problem given to Gauss, to solve when he was just 10 years old. He was asked to find the sum of the positive integers from 1 to 100. He replied that the sum is 5050. Can you guess how could he do it?

$$\text{Let } S = 1 + 2 + 3 + \dots + 99 + 100$$

And then, reverse the numbers to write

$$S = 100 + 99 + \dots + 3 + 2 + 1$$

When he added these two, term by term he got,

$$\begin{aligned} 2S &= (100 + 1) + (99 + 2) + \dots + (3 + 98) + (2 + 99) + (1 + 100) \\ &= 101 + 101 + \dots + 101 + 101 \text{ (100 times) (check this out and discuss)} \end{aligned}$$

$$\text{So, } S = \frac{100 \times 101}{2} = 5050, \text{ i.e., the sum} = 5050.$$



Carl Fredrich Gauss
(1777-1855) was a great
German Mathematician



6.4.2 Sum of n terms of an A.P.

We will now use the same technique that was used by Gauss to find the sum of the first n terms of an A.P. : $a, a + d, a + 2d, \dots$

The n^{th} term of this A.P. $a_n = a + (n - 1)d$.

Let S_n denote the sum of the first n terms of the A.P.

$$\therefore S_n = a + (a + d) + (a + 2d) + \dots + a + (n - 1)d$$

By writing S_n in two different orders, we get

$$S_n = [a + (n - 1)d] + [a + (n - 2)d] + \dots + a$$

Adding term by term

$$\begin{aligned} 2S_n &= [2a + (n - 1)d] + [2a + (n - 1)d] + \dots + [2a + (n - 1)d] \quad n \text{ times} \\ &= n[2a + (n - 1)d] \end{aligned}$$

$$\therefore S_n = \frac{n}{2}[2a + (n - 1)d] = \frac{n}{2}[a + \{a + (n - 1)d\}] = \frac{n}{2} [\text{first term} + n^{\text{th}} \text{ term}] = \frac{n}{2}(a + a_n)$$

$$S_n = \frac{n}{2}[2a + (n - 1)d] \quad \text{or} \quad S_n = \frac{n}{2}(a + l) \quad [\because a_n = a + (n - 1)d]$$

If the first and last terms of an A.P. are given and the common difference is not given then

$$S_n = \frac{n}{2}(a + a_n) \text{ is very useful to find } S_n \text{ or } S_n = \frac{n}{2}(a + l) \text{ where 'l' is the last term.}$$

Now, we return to the example (c) in the introduction 6.1. The amount of money (in Rupees) in the money box of Hema's daughter on 1st, 2nd, 3rd, 4th birthday, ..., were 1000, 1500, 2000, 2500, ..., respectively.

This is an A.P.. We have to find the total money collected on her 21st birthday, i.e., the sum of the first 21 terms of this A.P..

Here, $a = 1000$, $d = 500$ and $n = 21$. Using the formula :

$$S_n = \frac{n}{2}[2a + (n - 1)d],$$

$$\text{we have } S = \frac{21}{2}[2 \times 1000 + (21 - 1) \times 500]$$

$$= \frac{21}{2}[2000 + 10000]$$

$$= \frac{21}{2}[12000] = 126000$$

So, the amount of money collected on her 21st birthday is ₹ 1,26,000.



We use S_n in place of S to denote the sum of first n terms of the A.P. so that we know how many terms we have added. We write S_{20} to denote the sum of the first 20 terms of an A.P.. The formula for the sum of the first n terms involves four quantities S_n, a, d and n . If we know any three of them, we can find the fourth.

Remark : The n^{th} term of an A.P. is the difference of the sum of first n terms and the sum of first $(n - 1)$ terms of it, i.e., $a_n = S_n - S_{n-1}$.



Do This

Find the sum of indicated number of terms in each of the following A.P.s

- (i) 16, 11, 6; 23 terms (ii) -0.5, -1.0, -1.5,; 10 terms
- (iii) $-1, \frac{1}{4}, \frac{3}{2}, \dots$; 10 terms

Let us consider some examples.

Example-11. If the sum of the first 14 terms of an A.P. is 1050 and its first term is 10, find the 20th term.

Solution : Here, $S_n = 1050; n = 14, a = 10$

$$S_n = \frac{n}{2}[2a + (n-1)d]$$

$$1050 = \frac{14}{2}[2(10) + 13d] = 140 + 91d$$

$$910 = 91d$$

$$\therefore d = 10$$

$$\therefore a_{20} = 10 + (20 - 1)10 = 200$$

Example-12. How many terms of the A.P. : 24, 21, 18, ... must be taken so that their sum is 78?

Solution : Here, $a = 24, d = 21 - 24 = -3, S_n = 78$. Let the number of terms of A.P. be n , then we need to find n .

We know that $S_n = \frac{n}{2}[2a + (n-1)d]$

$$78 = \frac{n}{2}[48 + (n-1)(-3)] = \frac{n}{2}[51 - 3n]$$

$$\text{or } 3n^2 - 51n + 156 = 0$$



$$\text{or } n^2 - 17n + 52 = 0$$

$$\text{or } (n - 4)(n - 13) = 0$$

$$\text{or } n = 4 \text{ or } 13$$

Both values of n are admissible. So, the number of terms is either 4 or 13.

Remarks :

1. In this case, the sum of the first 4 terms = the sum of the first 13 terms = 78.
2. Two answers are possible because the sum of the terms from 5th to 13th will be zero. This is because a is positive and d is negative, so that some terms are positive and some are negative, and will cancel out each other.

Example-13. Find the sum of :

- (i) the first 1000 natural numbers (ii) the first n natural numbers

Solution :

(i) Let $S = 1 + 2 + 3 + \dots + 1000$

Using the formula $S_n = \frac{n}{2}(a + l)$ we have

$$S_{1000} = \frac{1000}{2}(1 + 1000) = 500 \times 1001 = 500500$$

So, the sum of the first 1000 positive integers = 500500.

(ii) Let $S_n = 1 + 2 + 3 + \dots + n$

Here $a = 1$ and the last term l is n .

$$\text{Therefore, } S_n = \frac{n(1+n)}{2} \quad (\text{or}) \quad S_n = \frac{n(n+1)}{2}$$

The sum of first n positive integers is given by $S_n = \frac{n(n+1)}{2}$

Example-14. Find the sum of first 24 terms of the list of numbers whose n^{th} term is given by

$$a_n = 3 + 2n$$

Solution : As $a_n = 3 + 2n$,

so, $a_1 = 3 + 2 = 5$

$$a_2 = 3 + 2 \times 2 = 7$$

$$a_3 = 3 + 2 \times 3 = 9$$

...



List of numbers becomes 5, 7, 9, 11, ...

Here, $7 - 5 = 9 - 7 = 11 - 9 = 2$ and so on.

So, it forms an A.P. with first term $a = 5$ and common difference, $d = 2$.

To find S_{24} , we have $n = 24$, $a = 5$, $d = 2$.

$$\text{Therefore, } S_{24} = \frac{24}{2} [2 \times 5 + (24 - 1) \times 2] = 12(10 + 46) = 672$$

So, the sum of first 24 terms of the list of numbers is 672.

Example-15. A manufacturer of TV sets produced 600 sets in the third year and 700 sets in the seventh year. Assuming that the production increases uniformly by a fixed number every year, find:

- (i) the production in the 1st year
- (ii) the production in the 10th year
- (iii) the total production in first 7 years

Solution : (i) Since the production increases uniformly by a fixed number every year, the number of TV sets manufactured in 1st, 2nd, 3rd, ..., years will form an A.P..

Let us denote the number of TV sets manufactured in the n th year by a_n .

$$\text{Then, } a_3 = 600 \text{ and } a_7 = 700$$

$$\text{or, } a + 2d = 600$$

$$\text{and } a + 6d = 700$$

Solving these equations, we get $d = 25$ and $a = 550$.

Therefore, production of TV sets in the first year is 550.

$$\text{(ii) Now } a_{10} = a + 9d = 550 + 9 \times 25 = 775$$

So, production of TV sets in the 10th year is 775.

$$\text{(iii) Also, } S_7 = \frac{7}{2} [2 \times 550 + (7 - 1) \times 25]$$

$$\text{or } = \frac{7}{2} [1100 + 150] = 4375$$

Thus, the total production of TV sets in first 7 years is 4375.





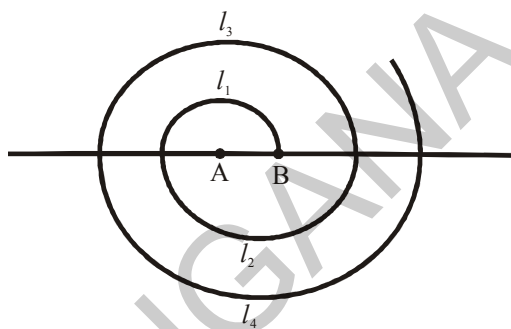
Exercise - 6.3

- Find the sum of the following A.P.s:
 - 2, 7, 12, . . . , to 10 terms.
 - 37, –33, –29, . . . , to 12 terms.
 - 0.6, 1.7, 2.8, . . . , to 100 terms.
 - $\frac{1}{15}, \frac{1}{12}, \frac{1}{10}, \dots$, to 11 terms.
- Find the sums given below :
 - $7 + 10\frac{1}{2} + 14 + \dots + 84$
 - $34 + 32 + 30 + \dots + 10$
 - $-5 + (-8) + (-11) + \dots + (-230)$
- In an A.P.:
 - given $a = 5, d = 3, a_n = 50$, find n and S_n .
 - given $a = 7, a_{13} = 35$, find d and S_{13} .
 - given $a_{12} = 37, d = 3$, find a and S_{12} .
 - given $a_3 = 15, S_{10} = 125$, find d and a_{10} .
 - given $a = 2, d = 8, S_n = 90$, find n and a_n .
 - given $a_n = 4, d = 2, S_n = -14$, find n and a .
 - given $l = 28, S_9 = 144$, and there are total 9 terms, find a .
- The first and the last terms of an A.P. are 17 and 350 respectively. If the common difference is 9, how many terms are there and what is their sum?
- Find the sum of first 51 terms of an A.P. whose second and third terms are 14 and 18 respectively.
- If the sum of first 7 terms of an A.P. is 49 and that of 17 terms is 289, find the sum of first n terms.
- Show that $a_1, a_2, \dots, a_n, \dots$ form an A.P. where a_n is defined as below.
Also find the sum of the first 15 terms in each case.
 - $a_n = 3 + 4n$
 - $a_n = 9 - 5n$
- If the sum of the first n terms of an A.P. is $4n - n^2$, what is the first term (note that the first term is S_1)? What is the sum of first two terms? What is the second term? Similarly, find the 3rd, the 10th and the n th terms.
- Find the sum of the first 40 positive integers divisible by 6.
- A sum of ₹ 700 is to be used to give seven cash prizes to students of a school for their overall academic performance. If each prize is ₹ 20 less than its preceding prize, find the value of each of the prizes.



11. Students of a school decided to plant trees in and around the school to reduce air pollution. It was decided that the number of trees, that each section of each class will plant, will be the same as the class, in which they are studying, e.g., a section of Class I will plant 1 tree, a section of Class II will plant 2 trees and so on till Class XII. There are three sections of each class. How many trees will be planted by the students?

12. A spiral is made up of successive semicircles, with centres alternately at A and B, starting with centre at A, of radii 0.5 cm, 1.0 cm, 1.5 cm, 2.0 cm, . . . as shown in Figure. What is the total length of such a spiral made up of thirteen consecutive semicircles? (Take $\pi = \frac{22}{7}$)



[Hint : Length of successive semicircles is $l_1, l_2, l_3, l_4, \dots$ with centres at A, B, A, B, . . . , respectively.]

13. 200 logs are stacked in the following manner: 20 logs in the bottom row, 19 in the row above, 18 in the row above it and so on. In how many rows are the 200 logs placed and how many logs are in the top row?



14. In a bucket and ball race, a bucket is placed at the starting point, which is 5 m from the first ball, and the other balls are placed 3 m apart in a straight line. There are ten balls in the line.



A runner starts from the bucket, picks up the nearest ball, runs back with it, drops it in the bucket, runs back to pick up the next ball, runs to the bucket to drop it in, and she continues in the same way until all the balls are in the bucket. What is the total distance the runner has to run?

[Hint : To pick up the first ball and the second ball, the total distance (in metres) run by a runner is $2 \times 5 + 2 \times (5 + 3)$]



6.5 Geometric Progressions

Consider the following patterns

- (i) 30, 90, 270, 810 (ii) $\frac{1}{4}, \frac{1}{16}, \frac{1}{64}, \frac{1}{256}, \dots$
- (iii) 30, 24, 19.2, 15.36, 12.288

Can we write the next term in each of the patterns above?

In (i), each term is obtained by multiplying the preceding term by 3.

In (ii), each term is obtained by multiplying the preceding term by $\frac{1}{4}$.

In (iii), each term is obtained by multiplying the preceding term by 0.8.

In all the lists given above, we see that successive terms are obtained by multiplying the preceding term by a fixed number. Such a list of numbers is said to form **Geometric Progression (G.P.)**.

This fixed number is called the common ratio ' r ' of G.P. So in the above example (i), (ii), (iii) the common ratios are 3, $\frac{1}{4}$, 0.8 respectively.

Let us denote the first term of a G.P. by a and common ratio r . To get the second term according to the rule of Geometric Progression, we have to multiply the first term by the common ratio r , where $a \neq 0$, $r \neq 0$ and $r \neq 1$

\therefore The second term = ar

Third term = $ar \cdot r = ar^2$

$\therefore a, ar, ar^2, \dots$ is called the general form of a G.P.

In the above G.P. the ratio between any term (except first term) and its preceding term is ' r '

i.e., $\frac{ar}{a} = \frac{ar^2}{ar} = \dots = r$

If we denote the first term of GP by a_1 , second term by a_2 n^{th} term by a_n

then $\frac{a_2}{a_1} = \frac{a_3}{a_2} = \dots = \frac{a_n}{a_{n-1}} = r$

\therefore A list of numbers $a_1, a_2, a_3, \dots, a_n, \dots$ is called a geometric progression (G.P.), if each term is non zero and

$$\frac{a_n}{a_{n-1}} = r \quad (r \neq 1)$$

where n is a natural number and $n \geq 2$.





Do This

Find which of the following are not GPs

- | | |
|-------------------------|-------------------------------|
| 1. 6, 12, 24, 48, | 2. 1, 4, 9, 16, |
| 3. 1, -1, 1, -1, | 4. -4, -20, -100, -500, |

Some more example of GP are :

- (i) A person writes a letter to four of his friends. He asks each one of them to copy the letter and give it to four different persons with same instructions so that they can move the chain ahead similarly. Assuming that the chain is not broken the number of letters at first, second, third ... stages are

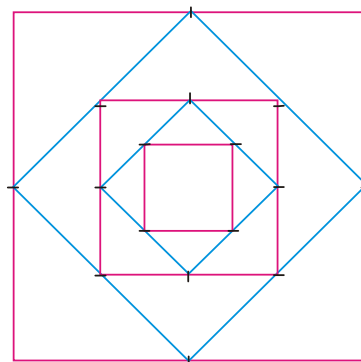
1, 4, 16, 64, 256 respectively.

- (ii) The total amount at the end of first , second, third year if ₹ 500/- is deposited in the bank with annual interest rate of 10% compounded annually is

550, 605, 665.5

- (iii) A square is drawn by joining the mid points of the sides of a given square. A third square is drawn inside the second square in the same way and this process continues indefinitely. If a side of the first square is 16cm then the area of first, second, third square will be respectively.

256, 128, 64, 32,



- (iv) Initially a pendulum swings through an arc of 18 cm. On each successive swing the length of the arc is 0.9^{th} part of the previous length. So the length of the arc at first, second, third..... swing will be respectively (in cm).

18, 16.2, 14.58, 13.122.....



Think - Discuss

1. Explain why each of the lists above is a G.P.
2. To know about a GP, what is the minimum information that we need?



Solution : (i) We know that a list of numbers $a_1, a_2, a_3, \dots, a_n, \dots$ is called a G.P. if each term is

non zero and $\frac{a_2}{a_1} = \frac{a_3}{a_2} = \dots = \frac{a_n}{a_{n-1}} = r$

Here all the terms are non zero. Further

$$\frac{a_2}{a_1} = \frac{6}{3} = 2$$

and $\frac{a_3}{a_2} = \frac{12}{6} = 2$

i.e., $\frac{a_2}{a_1} = \frac{a_3}{a_2} = 2$

So, the given list of number forms a G.P. with the common ratio 2.

(ii) All the terms are non zero.

$$\frac{a_2}{a_1} = \frac{-32}{64} = \frac{-1}{2}$$

and $\frac{a_3}{a_2} = \frac{16}{-32} = \frac{-1}{2}$

$$\therefore \frac{a_2}{a_1} = \frac{a_3}{a_2} = \frac{-1}{2}$$

So, the given list of numbers form a G.P. with common ratio $\frac{-1}{2}$.

(iii) All the terms are non zero.

$$\frac{a_2}{a_1} = \frac{32}{1} = 32 \quad \text{and} \quad \frac{a_3}{a_2} = \frac{8}{32} = \frac{1}{4}$$

Here $\frac{a_2}{a_1} \neq \frac{a_3}{a_2}$

So, the given list of numbers does not form G.P.

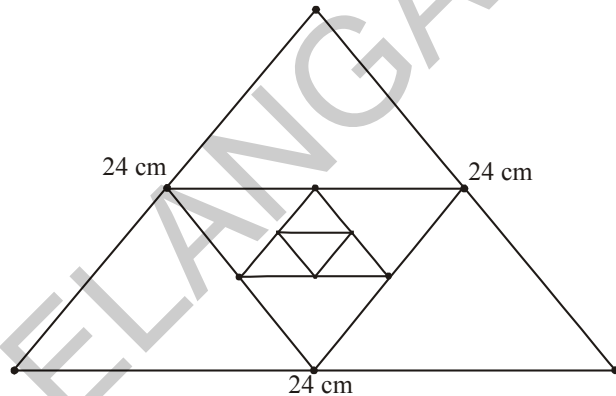




Exercise - 6.4

1. In which of the following situations, does the list of numbers involved is in the form of a G.P.?

- Salary of Sharmila: when her salary is ₹ 5,00,000 for the first year and expected to receive yearly increment of 10% .
- Number of bricks needed to make each step: if the stair case has total 30 steps, provided that bottom step needs 100 bricks and each successive step needs 2 bricks less than the previous step.
- Perimeter of the each triangle: when the mid points of sides of an equilateral triangle whose side is 24 cm are joined to form another triangle, whose mid points in turn are joined to form still another triangle and the process continues indefinitely.



2. Write three terms of the G.P. when the first term 'a' and the common ratio 'r' are given?

- | | |
|----------------------------------|--------------------------------------|
| (i) $a = 4; r = 3$ | (ii) $a = \sqrt{5}; r = \frac{1}{5}$ |
| (iii) $a = 81; r = \frac{-1}{3}$ | (iv) $a = \frac{1}{64}; r = 2$ |

3. Which of the following are G.P.? If they are in G.P. write next three terms?

- | | |
|--|---|
| (i) 4, 8, 16, ... | (ii) $\frac{1}{3}, \frac{-1}{6}, \frac{1}{12}, \dots$ |
| (iii) 5, 55, 555, ... | (iv) -2, -6, -18, ... |
| (v) $\frac{1}{2}, \frac{1}{4}, \frac{1}{6}, \dots$ | (vi) 3, -3^2 , 3^3 , ... |
| (vii) $x, 1, \frac{1}{x}, \dots, (x \neq 0)$ | (viii) $\frac{1}{\sqrt{2}}, -2, 4\sqrt{2}, \dots$ |
| (ix) 0.4, 0.04, 0.004, ... | |

4. Find x so that $x, x + 2, x + 6$ are consecutive terms of a geometric progression.



6.6 n^{th} term of a G.P.

Let us examine a problem. The number of bacteria in a certain petri dish culture triples every hour. If there were 30 bacteria present in the petri dish originally, then what would be the number of bacteria in fourth hour?

To answer this, let us first see what the number of bacteria in second hour would be.

Since for every hour it triples

$$\begin{aligned}\text{No. of bacteria in Second hour} &= 3 \times \text{no. of bacteria in first hour} \\ &= 3 \times 30 = 30 \times 3^1 \\ &= 30 \times 3^{(2-1)} \\ &= 90\end{aligned}$$

$$\begin{aligned}\text{No. of bacteria in third hour} &= 3 \times \text{no. of bacteria in second hour} \\ &= 3 \times 90 = 30 \times (3 \times 3) \\ &= 30 \times 3^2 = 30 \times 3^{(3-1)} \\ &= 270\end{aligned}$$

$$\begin{aligned}\text{No. of bacteria in fourth hour} &= 3 \times \text{no. of bacteria in third hour} \\ &= 3 \times 270 = 30 \times (3 \times 3 \times 3) \\ &= 30 \times 3^3 = 30 \times 3^{(4-1)} \\ &= 810\end{aligned}$$

Observe that we are getting a list of numbers

$$30, 90, 270, 810, \dots$$

These numbers are in GP (why?)

Now looking at the pattern formed above, can you find number of bacteria in 20th hour?

You may have already got some idea from the way we have obtained the number of bacteria as above. By using the same pattern, we can compute that number of bacteria in 20th hour.

$$\begin{aligned}\text{The number of bacteria in } 20^{\text{th}} \text{ hour} &= 30 \times \underbrace{(3 \times 3 \times \dots \times 3)}_{19 \text{ terms}} \\ &= 30 \times 3^{19} = 30 \times 3^{(20-1)}\end{aligned}$$

This example would have given you some idea about how to write the 25th term, 35th term and more generally the n^{th} term of the G.P.

Let a_1, a_2, a_3, \dots be in GP whose 'first term' a_1 is ' a ' and the common ratio is ' r '.



then the second term $a_2 = ar = ar^{(2-1)}$

the third term $a_3 = a_2 \times r = (ar) \times r = ar^2 = ar^{(3-1)}$

the fourth term $a_4 = a_3 \times r = ar^2 \times r = ar^3 = ar^{(4-1)}$

.....

Looking at the pattern we can say that n^{th} term $a_n = ar^{n-1}$

So n^{th} term of a G.P. with first term 'a' and common ratio 'r' is given by $a_n = ar^{n-1}$.

Let us consider some examples

Example-20. Find the 20th and n^{th} term of the G.P. $\frac{5}{2}, \frac{5}{4}, \frac{5}{8}, \dots$

Solution : Here $a = \frac{5}{2}$ and $r = \frac{\frac{5}{4}}{\frac{5}{2}} = \frac{1}{2}$

Then $a_{20} = ar^{20-1} = \frac{5}{2} \left(\frac{1}{2}\right)^{19} = \frac{5}{2^{20}}$

and $a_n = ar^{n-1} = \frac{5}{2} \left(\frac{1}{2}\right)^{n-1} = \frac{5}{2^n}$

Example-21. Which term of the G.P. : 2, $2\sqrt{2}$, 4 is 128 ?

Solution : Here $a = 2$ $r = \frac{2\sqrt{2}}{2} = \sqrt{2}$

Let 128 be the n^{th} term of the G.P.

Then $a_n = ar^{n-1} = 128$

$$2 \cdot (\sqrt{2})^{n-1} = 128$$

$$(\sqrt{2})^{n-1} = 64$$

$$(2)^{\frac{n-1}{2}} = 2^6$$



$$\Rightarrow \frac{n-1}{2} = 6$$

$$\therefore n = 13.$$

Hence 128 is the 13th term of the G.P.

Example-22. In a GP the 3rd term is 24 and 6th term is 192. Find the 10th term.

Solution : Here $a_3 = ar^2 = 24$... (1)

$$a_6 = ar^5 = 192$$
 ... (2)

Dividing (2) by (1) we get $\frac{ar^5}{ar^2} = \frac{192}{24}$

$$\Rightarrow r^3 = 8 = 2^3$$

$$\Rightarrow r = 2$$

Substituting $r = 2$ in (1) we get $a = 6$.

$$\therefore a_{10} = ar^9 = 6(2)^9 = 3072.$$



Exercise-6.5

1. For each geometric progression given below, find the common ratio ' r ', and find n^{th} term

(i) $3, \frac{3}{2}, \frac{3}{4}, \frac{3}{8}, \dots$

(ii) $2, -6, 18, -54$

(iii) $-1, -3, -9, -27, \dots$

(iv) $5, 2, \frac{4}{5}, \frac{8}{25}, \dots$

2. Find the 10th and n^{th} term of G.P. : 5, 25, 125,

3. Find the indicated term of each Geometric Progression

(i) $a_1 = 9; r = \frac{1}{3};$ find a_7

(ii) $a_1 = -12; r = \frac{1}{3};$ find a_6

4. Which term of the G.P.

(i) $2, 8, 32, \dots$ is 512 ?

(ii) $\sqrt{3}, 3, 3\sqrt{3}, \dots$ is 729 ?

(iii) $\frac{1}{3}, \frac{1}{9}, \frac{1}{27}, \dots$ is $\frac{1}{2187}$?



- Find the 12th term of a G.P. whose 8th term is 192 and the common ratio is 2.
- The 4th term of a geometric progression is $\frac{2}{3}$ and the seventh term is $\frac{16}{81}$. Find the geometric progression.
- If the geometric progressions 162, 54, 18 and $\frac{2}{81}, \frac{2}{27}, \frac{2}{9}$ have their n^{th} term equal. Find the value of n .



Optional Exercise

[For extensive Learning]

- Which term of the A.P. : 121, 117, 113, ..., is the first negative term?

[Hint : Find n for $a_n < 0$]

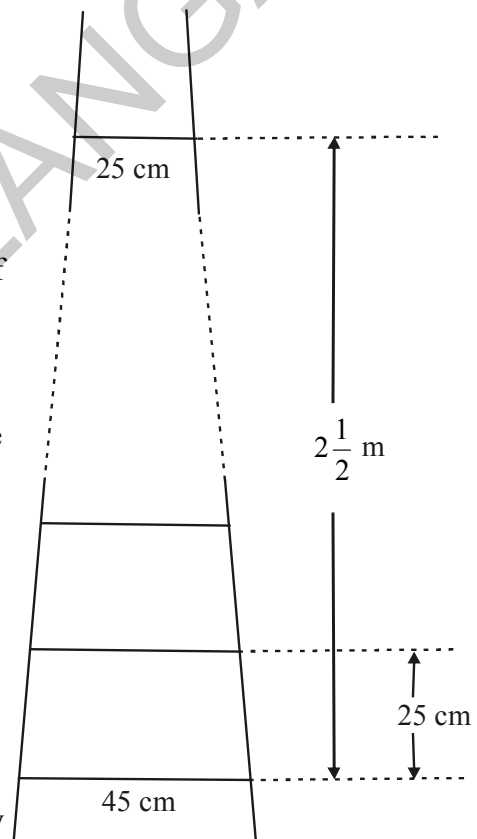
- The sum of the third and the seventh terms of an A.P. is 6 and their product is 8. Find the sum of first sixteen terms of the A.P..

- A ladder has rungs 25 cm apart. The rungs decrease uniformly in length from 45 cm at the bottom to 25 cm at the top. If the top and the bottom rungs are $2\frac{1}{2}$ m apart, what is the length of the wood required for the rungs?

[Hint : Number of rungs = $\frac{250}{25} + 1$]

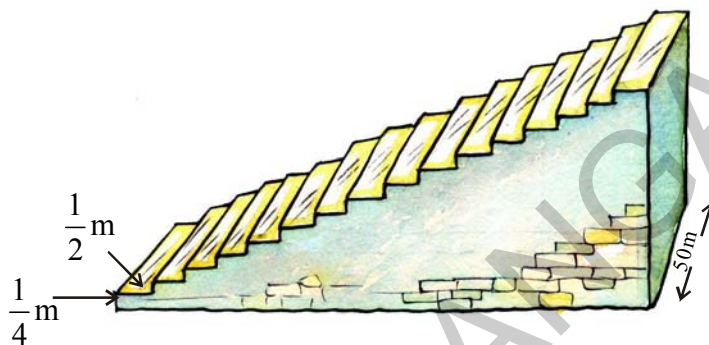
- The houses of a row are numbered consecutively from 1 to 49. Show that there is a value of x such that the sum of the numbers of the houses preceding the house numbered x is equal to the sum of the numbers of the houses following it. And find this value of x .

[Hint : $S_{x-1} = S_{49} - S_x$]



5. The sitting area around a football ground comprises of 15 steps, each of which is 50 m long and built of bricks. Each step has a rise of $\frac{1}{4}$ m and a tread of $\frac{1}{2}$ m. (as shown in the figure below). Calculate the total volume of the sitting area.

[Hint : Volume of the first step = $\frac{1}{4} \times \frac{1}{2} \times 50 \text{ m}^3$]



6. 150 workers were engaged to finish a piece of work in a certain number of days. Four workers dropped from the work on the second day. Four workers dropped on third day and so on. It took 8 more days to finish the work. Find the number of days in which the work was completed.

[Let the no. of days to finish the work be 'x' then

$$150x = \frac{x+8}{2} [2 \times 150 + (x+8-1)(-4)]$$

[Ans. $x = 17 \Rightarrow x + 8 = 17 + 8 = 25$]

7. A machine costs ₹ 5,00,000. If its value depreciates 15% in the first year, $13\frac{1}{2}$ % in the second year, 12% in the third year and so on. What will be its value at the end of 10 years, when all the percentages will be applied to the original cost?

[Hint: Total depreciation = $15 + 13\frac{1}{2} + 12 + \dots$ 10 terms.

$$S_n = \frac{10}{2} [30 - 13.5] = 82.5\%$$

\therefore after 10 year original cost = $100 - 82.5 = 17.5$ i.e., 17.5% of 5,00,000]



Suggested Projects

1. To verify that a given list of numbers is an A.P. or not using graphical method (using Bar graph).
2. To verify the sum of '10' terms of A.P. and generalize it (using Grid paper).



What We Have Discussed



In this chapter, you have studied the following points :

1. An **arithmetic progression** (A.P.) is a list of numbers in which each term is obtained by adding a fixed number d to the preceding term, except the first term. The fixed number d is called the **common difference**.

The terms of A.P. are $a, a + d, a + 2d, a + 3d, \dots$

2. A given list of numbers a_1, a_2, a_3, \dots is an A.P., if the differences $a_2 - a_1, a_3 - a_2, a_4 - a_3, \dots$, give the same value, i.e., if $a_{k+1} - a_k$ is the same for different values of k .
3. In an A.P. with first term a and common difference d , the n^{th} term (or the general term) is given by $a_n = a + (n - 1) d$.
4. The sum of the first n terms of an A.P. is given by :

$$S = \frac{n}{2}[2a + (n - 1)d]$$

5. If l is the last term of the finite A.P., say the n^{th} term, then the sum of all terms of the A.P. is given by :

$$S = \frac{n}{2}(a + l).$$

6. A **Geometric Progression** (G.P.) is a list of numbers in which first term is non-zero each succeeding term is obtained by multiplying preceding term with a fixed non zero number ' r ' except first term. This fixed number is called **common ratio** ' r '.

The general form of GP is a, ar, ar^2, ar^3, \dots

7. If the first term and common ratio of a GP are a and r respectively then n^{th} term $a_n = ar^{n-1}$. (Here $a \neq 0, r \neq 0$ and $r \neq 1$)



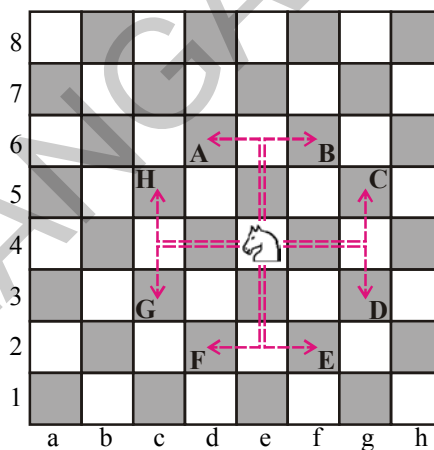


7.1 Introduction

You know that in chess, the Knight moves in 'L' shape (two squares vertically and one square horizontally or vice - versa) see figure. It can jump over other pieces too. A Bishop moves diagonally, as many steps as are free in front of it.

Find out how other pieces move. Also locate Knight, Bishop and other pieces on the board and see how they move.

Consider the position of Knight at $(0, 0)$. It can move in 4 directions as shown by dotted lines in the figure. Suppose, it is at B then its position will be expressed as f6. Find the coordinates of its position after the various moves shown in the figure.



Do This

- From the figure write coordinates of the points A, B, C, D, E, F, G, H.
- Find the distance covered by the Knight in each of its 8 moves i.e. find the distance of A, B, C, D, E, F, G and H from its original position.
- What is the distance between two points H and C? Also find the distance between two points A and B

7.2 Distance Between Two Points

The two points $(2, 0)$ and $(6, 0)$ lie on the X-axis as shown in figure. It is easy to see that the distance between two points A and B as 4 units.

We can say the distance between points lying on X-axis is the difference between the x-coordinates.



What is the distance between $(-2, 0)$ and $(-6, 0)$?

The difference in the value of x -coordinates is

$$(-6) - (-2) = -4 \text{ (Negative)}$$

We never say the distance in negative values.

So, we will take absolute value of the difference.

Therefore, the distance from 'A' and 'B'

$$= |(-6) - (-2)| = |-4| = 4 \text{ units.}$$

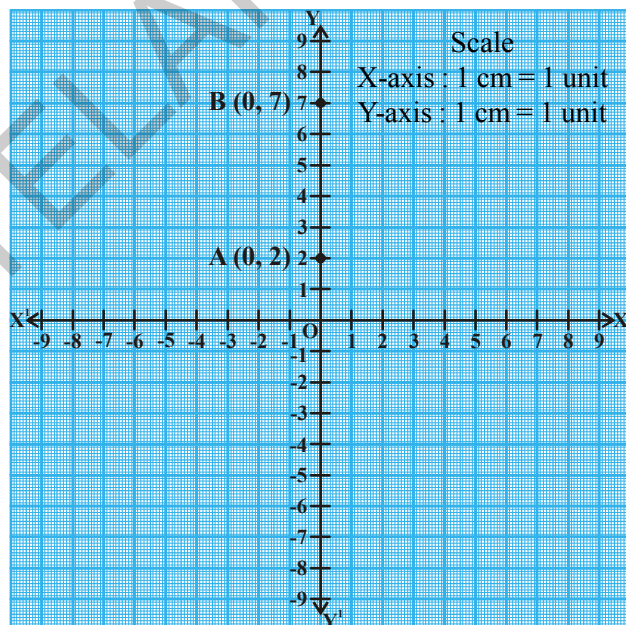
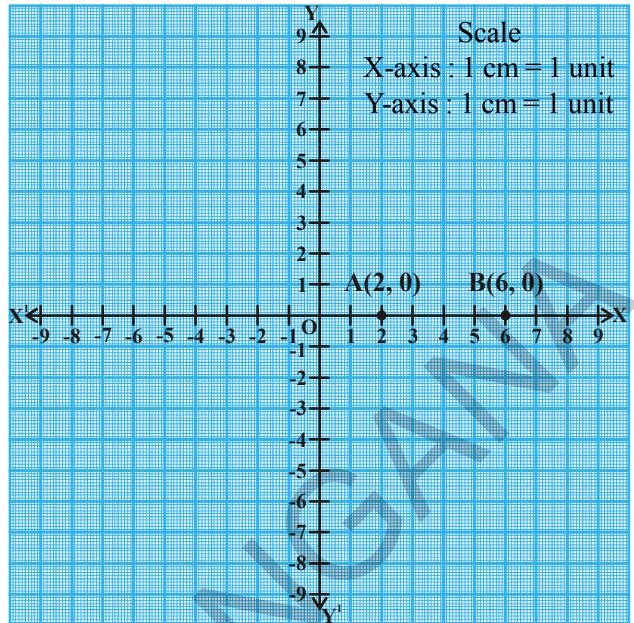
So, in general for the points $A(x_1, 0)$ and $B(x_2, 0)$ that lie on the X -axis, the distance between A and B is $|x_2 - x_1|$.

Similarly, if two points lie on Y -axis, then the distance between the points A and B would be the difference between their y coordinates of the points.

The distance between two points $(0, y_1)$ and $(0, y_2)$ would be $|y_2 - y_1|$.

For example, let the points be $A(0, 2)$ and $B(0, 7)$

Then, the distance between A and B is $|7 - 2| = 5$ units.



Do this

1. Where do points $(-4, 0)$, $(2, 0)$, $(6, 0)$ and $(-8, 0)$ lie on coordinate plane?
2. Find the distance between points (i) $(-4, 0)$ and $(6, 0)$; (ii) $(-4, 0)$ and $(-8, 0)$?





Try this

1. Where do points $(0, -3)$, $(0, -8)$, $(0, 6)$ and $(0, 4)$ lie on coordinate plane?
2. Find the distance between points (i) $(0, -3)$ and $(0, 6)$; (ii) $(0, -3)$ and $(0, -8)$?



Think & Discuss

How will you find the distance between two points in which x or y coordinates are same but not zero?

7.3 Distance Between Two Points on a Line Parallel to the Coordinate Axes

Consider the points $A(x_1, y_1)$ and $B(x_2, y_1)$. Since the y -coordinates are equal, points lie on a line, parallel to X -axis.

AP and BQ are drawn perpendicular to X -axis.

Observe the figure. $APQB$ is a rectangle.

Therefore, $AB = PQ$.

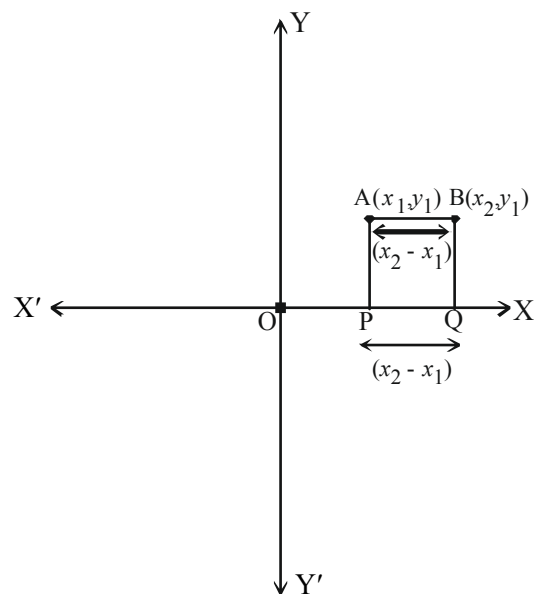
$PQ = |x_2 - x_1|$ (i.e., The modulus of difference between x coordinates)

Similarly, line joining two points $A(x_1, y_1)$ and $B(x_1, y_2)$ is parallel to Y -axis. Then the distance between these two points is $|y_2 - y_1|$ (It is read as modulus of the difference of y coordinates).

Example-1. What is the distance between $A(4, 0)$ and $B(8, 0)$.

Solution : The absolute value of the difference in the x coordinates is

$$|x_2 - x_1| = |8 - 4| = 4 \text{ units.}$$



Example-2. A and B are two points given by (8, 3), (-4, 3). Find the distance between A and B.

Solution : Here Points A and B are lying in two different quadrants and their y-coordinates are equal.

$$\text{Distance AB} = |x_2 - x_1| = |-4 - 8| = |-12| = 12 \text{ units}$$



Do This

Find the distance between the following points.

- i. (3, 8), (6, 8) ii. (-4, -3), (-8, -3) iii. (3, 4), (3, 8) (iv) (-5, -8), (-5, -12)

Let A and B denote the points (4, 0) and (0, 3) and 'O' be the origin.

The $\triangle AOB$ is a right angle triangle.

From the figure

OA = 4 units (x-coordinate)

OB = 3 units (y-coordinate)

Then distance AB = ?

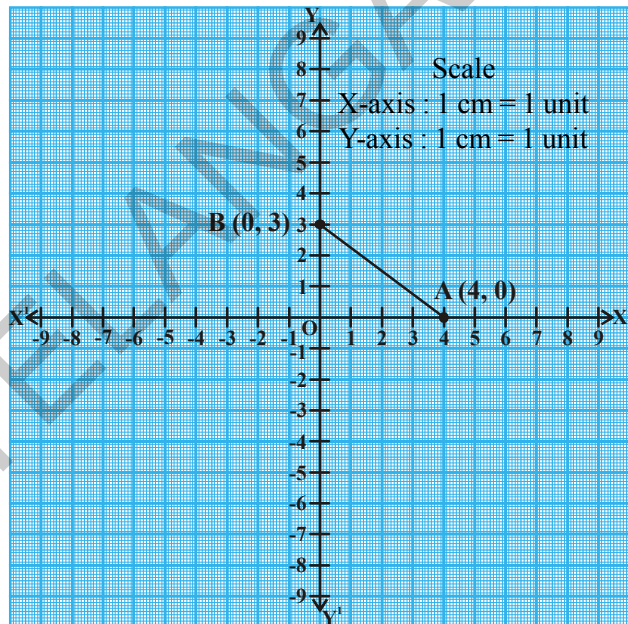
Hence, by using Pythagorean theorem

$$AB^2 = AO^2 + OB^2$$

$$AB^2 = 4^2 + 3^2$$

$$AB = \sqrt{16 + 9} = \sqrt{25} = 5$$

⇒ Distance between A and B is 5 units.



Do This

Find the distance between the following points

- (i) A (2, 0) and B(0, 4)
 (ii) P(0, 5) and Q(-12, 0)



Try This

Find the distance between points O (origin) and A (7, 4).





Think - Discuss

1. Ramu says the distance of a point $P(x_1, y_1)$ from the origin $O(0, 0)$ is $\sqrt{x_1^2 + y_1^2}$. Do you agree with Ramu? Why?

7.4 Distance Between Any Two Points in the plane

Let $A(x_1, y_1)$ and $B(x_2, y_2)$ be any two points in a plane as shown in figure.

Draw AP and BQ perpendiculars to X -axis

Draw a perpendicular AR from the point A on BQ .

Then $OP = x_1$, $OQ = x_2$ (Why?)

So, $PQ = OQ - OP = x_2 - x_1$

Observe the shape of $APQR$. It is a rectangle.

So $PQ = AR = x_2 - x_1$.

Also $QB = y_2$, $QR = y_1$,

So $BR = QB - QR = y_2 - y_1$

In $\triangle ARB$ (right triangle)

$AB^2 = AR^2 + RB^2$ (By Pythagorean theorem)

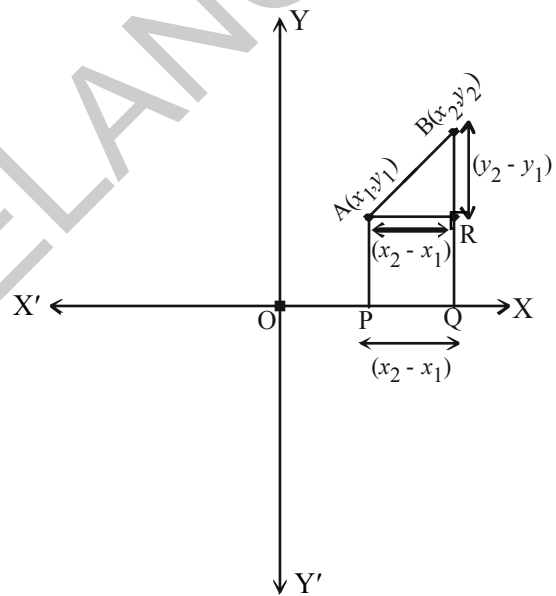
$$AB^2 = (x_2 - x_1)^2 + (y_2 - y_1)^2$$

$$\text{i.e., } AB = \sqrt{(x_2 - x_1)^2 + (y_2 - y_1)^2}$$

Hence, 'd' the distance between the points A and B is

$$d = \sqrt{(x_2 - x_1)^2 + (y_2 - y_1)^2}.$$

This is called the distance formula.



Think - Discuss

1. Ramu also writes the distance formula for $AB = \sqrt{(x_1 - x_2)^2 + (y_1 - y_2)^2}$ (why?)



Example-3. Find the distance between two points A(4, 3) and B(8, 6)

Solution : Compare these points with $(x_1, y_1), (x_2, y_2)$

$$x_1 = 4, x_2 = 8, y_1 = 3, y_2 = 6$$

Using distance formula

$$d = \sqrt{(x_2 - x_1)^2 + (y_2 - y_1)^2}$$

$$\begin{aligned} \text{distance AB} &= \sqrt{(8-4)^2 + (6-3)^2} = \sqrt{4^2 + 3^2} \\ &= \sqrt{16+9} = \sqrt{25} = 5 \text{ units.} \end{aligned}$$



Do This

Find the distance between the following pair of points

(i) (7, 8) and (-2, 3)

(ii) (-8, 6) and (2, 0)



Try This

Find the distance between A(1, -3) and B(-4, 4) and round it off to two decimal places.



Think & Discuss

Sridhar calculated the distance between T(5, 2) and R(-4, -1) to the nearest decimal as 9.5 units.

Now, find the distance between P(4, 1) and Q(-5, -2). What do you observe in these two results?

Let us observe some more examples.

Example-4. Show that the points A(4, 2), B(7, 5) and C(9, 7) are three points lying on the same line.

Solution : Let us find the distances AB, BC, AC by using distance formula,

$$d = \sqrt{(x_2 - x_1)^2 + (y_2 - y_1)^2}$$



$$\text{So, } d = AB = \sqrt{(7-4)^2 + (5-2)^2} = \sqrt{3^2 + 3^2} = \sqrt{9+9} = \sqrt{18} = \sqrt{9 \times 2} = 3\sqrt{2} \text{ units.}$$

$$BC = \sqrt{(9-7)^2 + (7-5)^2} = \sqrt{2^2 + 2^2} = \sqrt{4+4} = \sqrt{8} = \sqrt{4 \times 2} = 2\sqrt{2} \text{ units}$$

$$AC = \sqrt{(9-4)^2 + (7-2)^2} = \sqrt{5^2 + 5^2} = \sqrt{25+25} = \sqrt{50} = \sqrt{25 \times 2} = 5\sqrt{2} \text{ units.}$$

$$\text{Now } AB + BC = 3\sqrt{2} + 2\sqrt{2} = 5\sqrt{2} = AC.$$

Therefore, the three points (4, 2), (7, 5) and (9, 7) lie on a straight line.

(Note: Points that lie on the same line are called collinear points.)

Example-5. Do the points (3, 2), (-2, -3) and (2, 3) form a triangle?

Solution : Let us apply the distance formula to find the lengths PQ, QR and PR, where P(3, 2), Q(-2, -3) and R(2, 3) are the given points.

$$PQ = \sqrt{(-2-3)^2 + (-3-2)^2} = \sqrt{(-5)^2 + (-5)^2} = \sqrt{25+25} = \sqrt{50} = 7.07 \text{ units (approx)}$$

$$QR = \sqrt{(2-(-2))^2 + (3-(-3))^2} = \sqrt{(4)^2 + (6)^2} = \sqrt{52} = 7.21 \text{ units (approx)}$$

$$PR = \sqrt{(2-3)^2 + (3-2)^2} = \sqrt{(-1)^2 + 1^2} = \sqrt{2} = 1.41 \text{ units (approx)}$$

Since the sum of any two of these lengths is greater than the third length, the points P, Q and R form a scalene triangle.

Example-6. Show that the points (1, 7), (4, 2), (-1, -1) and (-4, 4) are the vertices of a square.

Solution : Let A(1, 7), B(4, 2), C(-1, -1) and D(-4, 4) be the given points.

One way of showing that ABCD is a square is to use the property that all its sides should be equal and both its diagonals should also be equal. Now, the sides are

$$AB = \sqrt{(1-4)^2 + (7-2)^2} = \sqrt{9+25} = \sqrt{34} \text{ units}$$

$$BC = \sqrt{(4+1)^2 + (2+1)^2} = \sqrt{25+9} = \sqrt{34} \text{ units}$$

$$CD = \sqrt{(-1+4)^2 + (-1-4)^2} = \sqrt{9+25} = \sqrt{34} \text{ units}$$

$$DA = \sqrt{(-4-1)^2 + (4-7)^2} = \sqrt{25+9} = \sqrt{34} \text{ units}$$



and diagonal are $AC = \sqrt{(1+1)^2 + (7+1)^2} = \sqrt{4+64} = \sqrt{68}$ units

$$BD = \sqrt{(4+4)^2 + (2-4)^2} = \sqrt{64+4} = \sqrt{68} \text{ units}$$

Since $AB = BC = CD = DA$ and $AC = BD$. So all the four sides of the quadrilateral ABCD are equal and its diagonals AC and BD are also equal. Therefore, ABCD is a square.

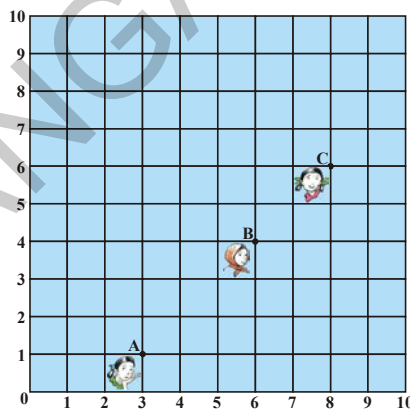
Example-7. The figure shows the arrangement of desks in a class room. Madhuri, Meena, Pallavi are seated at A(3, 1), B(6, 4) and C(8, 6) respectively. Do you think they are seated in a line? Give reasons for your answer.

Solution : Using the distance formula, we have

$$AB = \sqrt{(6-3)^2 + (4-1)^2} = \sqrt{9+9} = \sqrt{18} = 3\sqrt{2} \text{ units}$$

$$BC = \sqrt{(8-6)^2 + (6-4)^2} = \sqrt{4+4} = \sqrt{8} = 2\sqrt{2} \text{ units}$$

$$AC = \sqrt{(8-3)^2 + (6-1)^2} = \sqrt{25+25} = \sqrt{50} = 5\sqrt{2} \text{ units}$$



Since, $AB + BC = 3\sqrt{2} + 2\sqrt{2} = 5\sqrt{2} = AC$, we can say that the points A, B and C are collinear. Therefore, they are seated in a line.

Example-8. Find the relation between x and y such that the point (x, y) is equidistant from the points $(7, 1)$ and $(3, 5)$.

Solution : Given $P(x, y)$ be equidistant from the points $A(7, 1)$ and $B(3, 5)$.

$$\therefore AP = BP. \quad \text{So, } AP^2 = BP^2$$

$$\text{i.e., } (x-7)^2 + (y-1)^2 = (x-3)^2 + (y-5)^2$$

$$\text{i.e., } (x^2 - 14x + 49) + (y^2 - 2y + 1) = (x^2 - 6x + 9) + (y^2 - 10y + 25)$$

$$(x^2 + y^2 - 14x - 2y + 50) - (x^2 + y^2 - 6x - 10y + 34) = 0$$



$$-8x + 8y = -16 \text{ (Dividing both sides by } -8)$$

i.e., $x - y = 2$ which is the required relation.

Example-9. Find a point on the Y-axis which is equidistant from both the points A(6, 5) and B(-4, 3).

Solution : We know that a point on the Y-axis is of the form (0,y). So, let the point P(0, y) be equidistant from A and B. Then $PA = PB$

$$PA = \sqrt{(6-0)^2 + (5-y)^2}$$

$$PB = \sqrt{(-4-0)^2 + (3-y)^2}$$

$$\text{Given } PA = PB \text{ So } PA^2 = PB^2$$

$$\text{So, } (6-0)^2 + (5-y)^2 = (-4-0)^2 + (3-y)^2$$

$$\Rightarrow 36 + 25 + y^2 - 10y = 16 + 9 + y^2 - 6y$$

$$\Rightarrow 4y = 36$$

$$\therefore y = 9$$

So, the required point is (0, 9).

$$\text{Let us check our solution : } AP = \sqrt{(6-0)^2 + (5-9)^2} = \sqrt{36+16} = \sqrt{52}$$

$$BP = \sqrt{(-4-0)^2 + (3-9)^2} = \sqrt{16+36} = \sqrt{52}$$

So (0, 9) is equidistant from (6, 5) and (4, 3).



Exercise 7.1

- Find the distance between the following pairs of points
 - (2, 3) and (4, 1)
 - (-5, 7) and (-1, 3)
 - (-2, -3) and (3, 2)
 - (a, b) and (-a, -b)
- Find the distance between the points (0, 0) and (36, 15).
- Verify whether the points (1, 5), (2, 3) and (-2, -1) are collinear or not.
- Check whether (5, -2), (6, 4) and (7, -2) are the vertices of an isosceles triangle.
- Show that the points A(a, 0), B(-a, 0), C(0, $a\sqrt{3}$) form an equilateral triangle.

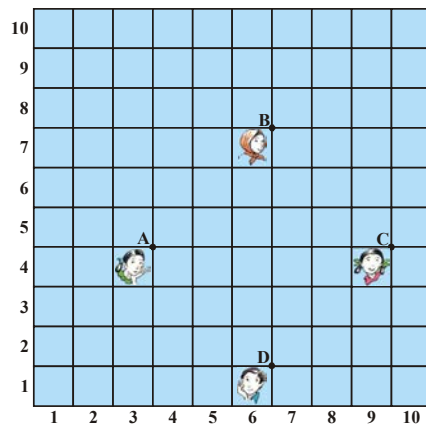


6. Prove that the points $(-7, -3)$, $(5, 10)$, $(15, 8)$ and $(3, -5)$ taken in order are the corners of a parallelogram.
7. Show that the points $(-4, -7)$, $(-1, 2)$, $(8, 5)$ and $(5, -4)$ taken in order are the vertices of a rhombus. Find its area.

(Hint : Area of rhombus = $\frac{1}{2} \times$ product of its diagonals)

8. Name the type of quadrilateral formed, if any, by the following points, and give reasons for your answer.
 - (i) $(-1, -2)$, $(1, 0)$, $(-1, 2)$, $(-3, 0)$
 - (ii) $(-3, 5)$, $(3, 1)$, $(1, -3)$, $(-5, 1)$
 - (iii) $(4, 5)$, $(7, 6)$, $(4, 3)$, $(1, 2)$
9. Find the point on the X-axis which is equidistant from $(2, -5)$ and $(-2, 9)$.
10. If the distance between two points $(x, 7)$ and $(1, 15)$ is 10, find the value of x .
11. Find the values of y for which the distance between the points $P(2, -3)$ and $Q(10, y)$ is 10 units.
12. Find the radius of the circle whose centre is $(3, 2)$ and passes through $(-5, 6)$.
13. Can you draw a triangle with vertices $(1, 5)$, $(5, 8)$ and $(13, 14)$? Give reason.
14. Find a relation between x and y such that the point (x, y) is equidistant from the points $(-2, 8)$ and $(-3, -5)$

15. In a class room, 4 friends are seated at the points A, B, C and D as shown in Figure. Jarina and Phani walk into the class and after observing for a few minutes Jarina asks Phani “Don’t you notice that ABCD is a square?” Phani disagrees. Using distance formula, decide who is correct and why?

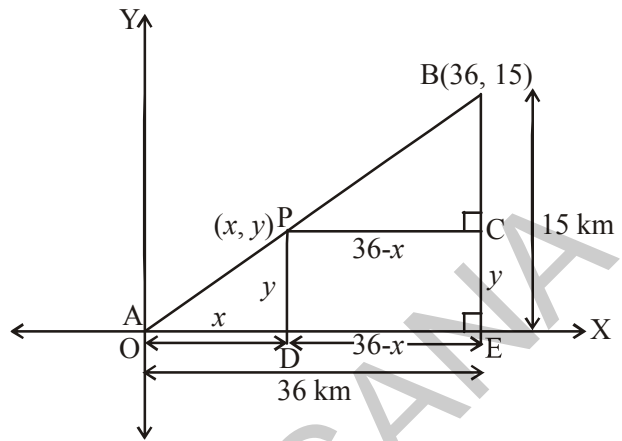


16. Find a relation between x and y such that the point (x, y) is equidistant from the points $(7, 1)$ and $(3, 5)$.



7.5 Section Formula

A and B are two towns. To reach B from A, we have to travel 36 km East and 15 km North from there (as shown in the figure). Suppose a telephone company wants to position a relay tower at P between A and B in such a way that the distance of the tower from B is twice its distance from A. If P lies on AB, it will divide AB in the ratio 1 : 2 (See figure).



If we take A as the origin O, and 1 km as one unit on both the axes, the coordinates of B will be (36, 15). In order to know the position of the tower, we must know the coordinates of P. How do we find these coordinates?

Let the coordinates of P be (x, y). Draw perpendiculars from P and B to the X-axis, meeting it in D and E, respectively. Draw PC perpendicular to BE. Then, by the AA similarity criterion, studied earlier, $\triangle POD$ and $\triangle BPC$ are similar.

$$\text{Therefore, } \frac{OD}{PC} = \frac{OP}{PB} = \frac{1}{2} \quad \text{and} \quad \frac{PD}{BC} = \frac{OP}{PB} = \frac{1}{2}$$

$$\text{So, } \frac{x}{36-x} = \frac{1}{2} \qquad \frac{y}{15-y} = \frac{1}{2}$$

$$2x = (36 - x) \qquad 2y = 15 - y$$

$$3x = 36 \qquad 3y = 15$$

$$x = 12 \qquad y = 5$$

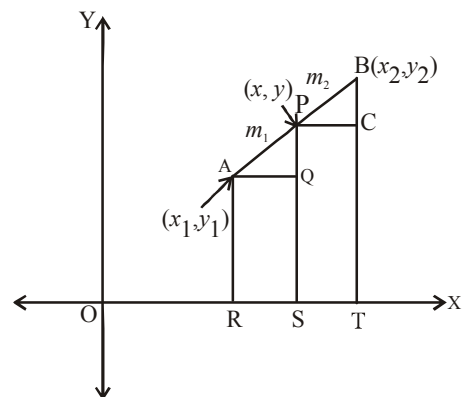
These equations give $x = 12$ and $y = 5$.

You can check that $P(12, 5)$ meets the condition that $OP : PB = 1 : 2$.

Consider any two points $A(x_1, y_1)$ and $B(x_2, y_2)$ and assume that P (x, y) divides AB internally in the ratio $m_1 : m_2$,

$$\text{i.e., } \frac{AP}{PB} = \frac{m_1}{m_2} \quad \dots (1) \quad (\text{See figure}).$$

Draw AR, PS and BT perpendicular to the X-axis.



Draw AQ and PC parallel to the X-axis. Then, by the AA similarity criterion,

$$\Delta PAQ \sim \Delta BPC$$

Therefore, $\frac{AP}{PB} = \frac{AQ}{PC} = \frac{PQ}{BC}$ (2)

Now, $AQ = RS = OS - OR = x - x_1$

$$PC = ST = OT - OS = x_2 - x$$

$$PQ = PS - QS = PS - AR = y - y_1$$

$$BC = BT - CT = BT - PS = y_2 - y$$



Substituting these values in (1), we get

$$\frac{m_1}{m_2} = \frac{x - x_1}{x_2 - x} = \frac{y - y_1}{y_2 - y} \quad \left[\because \frac{AP}{PB} = \frac{m_1}{m_2} \text{ from (1)} \right]$$

Taking $\frac{m_1}{m_2} = \frac{x - x_1}{x_2 - x}$, we get $x = \frac{m_1 x_2 + m_2 x_1}{m_1 + m_2}$

Similarly, taking $\frac{m_1}{m_2} = \frac{y - y_1}{y_2 - y}$, we get $y = \frac{m_1 y_2 + m_2 y_1}{m_1 + m_2}$

So, the coordinates of the point $P(x, y)$ which divides the line segment joining the points $A(x_1, y_1)$ and $B(x_2, y_2)$ in the ratio $m_1 : m_2$ **internally** are

$$\left(\frac{m_1 x_2 + m_2 x_1}{m_1 + m_2}, \frac{m_1 y_2 + m_2 y_1}{m_1 + m_2} \right) \quad \text{.....(3)}$$

This is known as the **section formula**.

This can also be derived by drawing perpendiculars from A, P and B on the Y-axis and proceeding as above.

If the ratio in which P divides AB is $k : 1$, then the coordinates of the point P are

$$\left(\frac{kx_2 + x_1}{k + 1}, \frac{ky_2 + y_1}{k + 1} \right).$$



Special Case : Let A (x_1, y_1) and B (x_2, y_2) be any two points. Then the midpoint of the line segment \overline{AB} divides the line segment in the ratio 1 : 1. Therefore, the coordinates of the mid-point P are

$$\left(\frac{1 \cdot x_1 + 1 \cdot x_2}{1+1}, \frac{1 \cdot y_1 + 1 \cdot y_2}{1+1} \right) = \left(\frac{x_1 + x_2}{2}, \frac{y_1 + y_2}{2} \right).$$

Let us solve few examples based on the section formula.

Example-10. Find the coordinates of the point which divides the line segment joining the points $(4, -3)$ and $(8, 5)$ in the ratio 3 : 1 internally.

Solution : Let $P(x, y)$ be the required point. Using the section formula

$$P(x, y) = \left(\frac{m_1 x_2 + m_2 x_1}{m_1 + m_2}, \frac{m_1 y_2 + m_2 y_1}{m_1 + m_2} \right), \text{ we get}$$

$$x = \frac{3(8) + 1(4)}{3+1} = \frac{24+4}{4} = \frac{28}{4} = 7,$$

$$y = \frac{3(5) + 1(-3)}{3+1} = \frac{15-3}{4} = \frac{12}{4} = 3$$

$P(x, y) = (7, 3)$ is the required point.

Example-11. Find the midpoint of the line segment joining the points $(3, 0)$ and $(-1, 4)$

Solution : The midpoint $M(x, y)$ of the line segment joining the points (x_1, y_1) and (x_2, y_2) .

$$M(x, y) = \left(\frac{x_1 + x_2}{2}, \frac{y_1 + y_2}{2} \right)$$

\therefore The mid point of the line segment joining the points $(3, 0)$ and $(-1, 4)$ is

$$M(x, y) = \left(\frac{3+(-1)}{2}, \frac{0+4}{2} \right) = \left(\frac{2}{2}, \frac{4}{2} \right) = (1, 2).$$



Do This

- 1 Find the point which divides the line segment joining the points $(3, 5)$ and $(8, 10)$ in the ratio 2 : 3 internally.
2. Find the midpoint of the line segment joining the points $(2, 7)$ and $(12, -7)$.




7.6 Trisectional Points of a Line segment

The points which divide a line segment into 3 equal parts are said to be the trisectional points.

Example-12. Find the coordinates of the points of trisection of the line segment joining the points A(2,-2) and B(-7, 4).

Solution : Let P and Q be the points of trisection of AB i.e., AP=PQ=QB (see figure below).

Therefore, P divides AB in the ratio 1 : 2 internally. 

Therefore, the coordinates of P are (by applying the section formula)

$$\begin{aligned} P(x, y) &= \left(\frac{m_1x_2 + m_2x_1}{m_1 + m_2}, \frac{m_1y_2 + m_2y_1}{m_1 + m_2} \right) \\ &= \left(\frac{1(-7) + 2(2)}{1 + 2}, \frac{1(4) + 2(-2)}{1 + 2} \right) \\ &= \left(\frac{-7 + 4}{3}, \frac{4 - 4}{3} \right) = \left(\frac{-3}{3}, \frac{0}{3} \right) = (-1, 0) \end{aligned}$$

Now, Q also divides AB in the ratio 2:1 internally.

So, the coordinates of Q are

$$\begin{aligned} &= \left(\frac{2(-7) + 1(2)}{2 + 1}, \frac{2(4) + 1(-2)}{2 + 1} \right) \\ &= \left(\frac{-14 + 2}{3}, \frac{8 - 2}{3} \right) = \left(\frac{-12}{3}, \frac{6}{3} \right) = (-4, 2) \end{aligned}$$

Therefore, the coordinates of the points of trisection of the line segment are P(-1, 0) and Q(-4, 2)

NOTE: P, Q divide \overline{AB} in the ratio 1:2 and 2:1.



Do This

1. Find the trisectional points of line segment joining (2, 6) and (-4, 8).
2. Find the trisectional points of line segment joining (-3, -5) and (-6, -8).





Try This

Let $A(4, 2)$, $B(6, 5)$ and $C(1, 4)$ be the vertices of $\triangle ABC$

1. AD is the median on BC . Find the coordinates of the point D .
2. Find the coordinates of the point P on AD such that $AP : PD = 2 : 1$.
3. Find the points Q and R which divide the median BE and median CF respectively in the ratio $2:1$.
4. What do you observe?

Justify that the point that divides each median in the ratio $2 : 1$ is the centroid of a triangle.

7.7 Centroid of a Triangle

The centroid of a triangle is the point of concurrency of its medians.

Let $A(x_1, y_1)$, $B(x_2, y_2)$ and $C(x_3, y_3)$ be the vertices of the triangle ABC .

Let AD be the median bisecting its base.

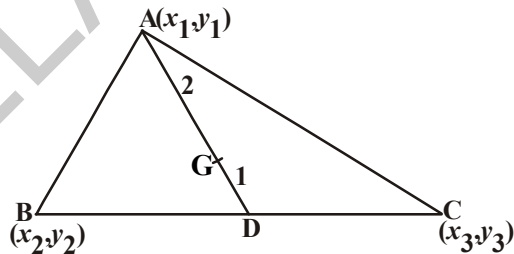
$$\text{Then, } D = \left(\frac{x_2 + x_3}{2}, \frac{y_2 + y_3}{2} \right)$$

Now the point G on AD which divides it in the ratio $2 : 1$ internally, is the centroid.

If (x, y) are the coordinates of G , then

$$G(x, y) = \left(\frac{2\left(\frac{x_2 + x_3}{2}\right) + 1(x_1)}{2 + 1}, \frac{2\left(\frac{y_2 + y_3}{2}\right) + 1(y_1)}{2 + 1} \right)$$

$$= \left(\frac{x_1 + x_2 + x_3}{3}, \frac{y_1 + y_2 + y_3}{3} \right)$$



Hence, the coordinates of the centroid are given by $\left(\frac{x_1 + x_2 + x_3}{3}, \frac{y_1 + y_2 + y_3}{3} \right)$.



Example-13. Find the centroid of the triangle whose vertices are $(3, -5)$, $(-7, 4)$ and $(10, -2)$.

Solution : The coordinates of the centroid are

$$= \left(\frac{x_1 + x_2 + x_3}{3}, \frac{y_1 + y_2 + y_3}{3} \right)$$

Therefore, Centroid of the triangle whose vertices are $(3, -5)$, $(-7, 4)$ and $(10, -2)$.

$$\left(\frac{3 + (-7) + 10}{3}, \frac{(-5) + 4 + (-2)}{3} \right) = (2, -1)$$

\therefore The centroid is $(2, -1)$.



Do This

Find the centroid of the triangle whose vertices are $(-4, 6)$, $(2, -2)$ and $(2, 5)$.

Example-14. In what ratio does the point $(-4, 6)$ divide the line segment joining the points $A(-6, 10)$ and $B(3, -8)$?

Solution : Let $(-4, 6)$ divide AB internally in the ratio $m_1 : m_2$. Using the section formula, we get

$$(-4, 6) = \left(\frac{3m_1 - 6m_2}{m_1 + m_2}, \frac{-8m_1 + 10m_2}{m_1 + m_2} \right) \quad \dots(1)$$

We know that if $(x, y) = (a, b)$ then $x = a$ and $y = b$.

$$\text{So, } -4 = \frac{3m_1 - 6m_2}{m_1 + m_2} \quad \text{and} \quad 6 = \frac{-8m_1 + 10m_2}{m_1 + m_2}$$

$$\text{Now, } -4 = \frac{3m_1 - 6m_2}{m_1 + m_2} \quad \text{gives us}$$

$$-4m_1 - 4m_2 = 3m_1 - 6m_2$$

$$\text{i.e., } 7m_1 = 2m_2$$

$$\frac{m_1}{m_2} = \frac{2}{7} \quad \text{i.e., } m_1 : m_2 = 2 : 7$$



We should verify that the ratio satisfies they-coordinate also.

$$\text{Now, } \frac{-8m_1 + 10m_2}{m_1 + m_2} = \frac{-8 \frac{m_1}{m_2} + 10}{\frac{m_1}{m_2} + 1} \quad (\text{Dividing numerator and denominator by } m_2)$$

$$= \frac{-8 \times \frac{2}{7} + 10}{\frac{2}{7} + 1} = \frac{\frac{-16}{7} + 10}{\frac{9}{7}} = \frac{-16 + 70}{9} = \frac{54}{9} = 6$$

Therefore, the point $(-4, 6)$ divides the line segment joining the points $A(-6, 10)$ and $B(3, -8)$ in the ratio $2 : 7$.



Think - Discuss

The line segment joining points $A(6, 9)$ and $B(-6, -9)$ is given

- In what ratio does the origin divide \overline{AB} ? And what is it called for \overline{AB} ?
- In what ratio does the point $P(2, 3)$ divide \overline{AB} ?
- In what ratio does the point $Q(-2, -3)$ divide \overline{AB} ?
- In how many equal parts is \overline{AB} divided by P and Q ?
- What do we call P and Q for \overline{AB} ?

Example-15. Find the ratio in which the y -axis divides the line segment joining the points $(5, -6)$ and $(-1, -4)$. Also find the point of intersection.

Solution : Let the ratio be $K : 1$. Then by the section formula, the coordinates of the point which divides AB in the ratio $K : 1$ are

$$\left(\frac{K(-1) + 1(5)}{K + 1}, \frac{K(-4) + 1(-6)}{K + 1} \right)$$

i.e., $\left(\frac{-K + 5}{K + 1}, \frac{-4K - 6}{K + 1} \right)$



This point lies on the Y-axis, and we know that on the Y-axis the abscissa is 0.

$$\text{Therefore, } \frac{-K+5}{K+1} = 0$$

$$-K + 5 = 0 \Rightarrow K = 5.$$

So, the ratio is $K : 1 = 5 : 1$

Putting the value of $K = 5$, we get the point of intersection as

$$= \left(\frac{-5+5}{5+1}, \frac{-4(5)-6}{5+1} \right) = \left(0, \frac{-20-6}{6} \right) = \left(0, \frac{-26}{6} \right) = \left(0, \frac{-13}{3} \right)$$

Example-16. Show that the points $A(7, 3)$, $B(6, 1)$, $C(8, 2)$ and $D(9, 4)$ taken in that order are vertices of a parallelogram.

Solution : Let the points $A(7, 3)$, $B(6, 1)$, $C(8, 2)$ and $D(9, 4)$ be vertices of a parallelogram.

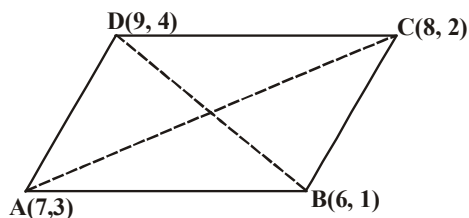
We know that the diagonals of a parallelogram bisect each other.

\therefore So the midpoint of the diagonals AC and DB should be same.

Now, we find the mid points of AC and DB by using $\left(\frac{x_1 + x_2}{2}, \frac{y_1 + y_2}{2} \right)$ formula.

$$\text{midpoint of } AC = \left(\frac{7+8}{2}, \frac{3+2}{2} \right) = \left(\frac{15}{2}, \frac{5}{2} \right)$$

$$\text{midpoint of } DB = \left(\frac{9+6}{2}, \frac{4+1}{2} \right) = \left(\frac{15}{2}, \frac{5}{2} \right)$$



Hence, midpoint of AC and midpoint of DB is same.

Therefore, the points A, B, C, D are vertices of a parallelogram.

Example-17. If the points $A(6, 1)$, $B(8, 2)$, $C(9, 4)$ and $D(p, 3)$ are the vertices of a parallelogram, taken in order, find the value of p .

Solution : We know that diagonals of parallelogram bisect each other.

So, the coordinates of the midpoint of AC = Coordinates of the midpoint of BD .

$$\text{i.e., } \left(\frac{6+9}{2}, \frac{1+4}{2} \right) = \left(\frac{8+p}{2}, \frac{5}{2} \right)$$

$$\left(\frac{15}{2}, \frac{5}{2} \right) = \left(\frac{8+p}{2}, \frac{5}{2} \right)$$

$$\frac{15}{2} = \frac{8+p}{2} \text{ from this we get } 15 = 8 + p \Rightarrow p = 7.$$





Exercise - 7.2

1. Find the point which divides the line segment joining the points $(-1, 7)$ and $(4, -3)$ in the ratio $2 : 3$.
2. Find the points of trisection of the line segment joining $(4, -1)$ and $(-2, -3)$.
3. Find the ratio in which the line segment joining the points $(-3, 10)$ and $(6, -8)$ is divided by $(-1, 6)$.
4. If $(1, 2)$, $(4, y)$, $(x, 6)$ and $(3, 5)$ are the vertices of a parallelogram taken in order, find x and y .
5. Find the point A, where AB is the diameter of a circle whose centre is $(2, -3)$ and B is $(1, 4)$.
6. If A and B are $(-2, -2)$ and $(2, -4)$ respectively, find the P on AB such that $AP = \frac{3}{7} AB$.
7. Find the points which divide the line segment joining A $(-4, 0)$ and B $(0, 6)$ into four equal parts.
8. Find the points which divides the line segment joining A $(-2, 2)$ and B $(2, 8)$ into four equal parts.
9. Find the point which divides the line segment joining the points $(a + b, a - b)$ and $(a - b, a + b)$ in the ratio $3 : 2$ internally.
10. Find the centroid of the triangles with vertices:
 - i. $(-1, 3)$, $(6, -3)$ and $(-3, 6)$
 - ii. $(6, 2)$, $(0, 0)$ and $(4, -7)$
 - iii. $(1, -1)$, $(0, 6)$ and $(-3, 0)$
11. Find the point A (x, y) when C divides AB in the ratio $2 : 3$. Points B and C are given as $(-5, 8)$ and $(3, 6)$.
12. The line segment AB meets the coordinate axes in points A and B. If point P $(3, 6)$ divides AB in the ratio $2 : 3$, then find the points A and B.



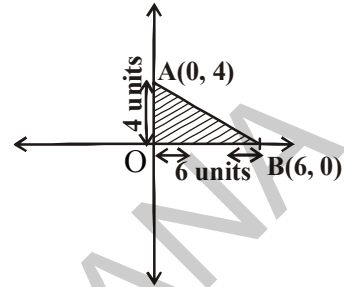
7.8 Area of the Triangle

Consider the points $A(0, 4)$ and $B(6, 0)$ which form a triangle with origin O on a plane as shown in the figure.

What is the area of the $\triangle AOB$?

$\triangle AOB$ is a right angle triangle with the base as 6 units (i.e., x coordinate) and height as 4 units (i.e., y coordinate).

$$\begin{aligned} \therefore \text{Area of } \triangle AOB &= \frac{1}{2} \times \text{base} \times \text{height} \\ &= \frac{1}{2} \times 6 \times 4 = 12 \text{ square units.} \end{aligned}$$



Try This

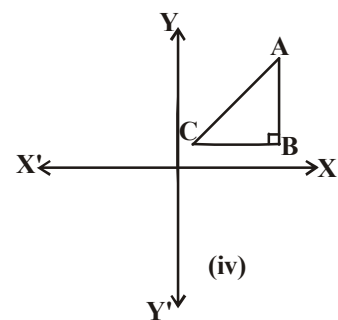
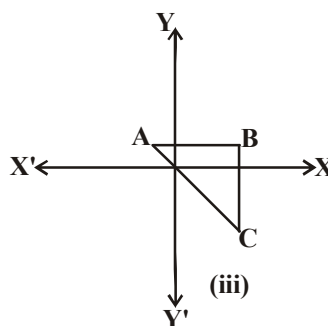
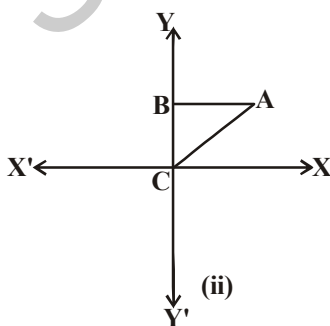
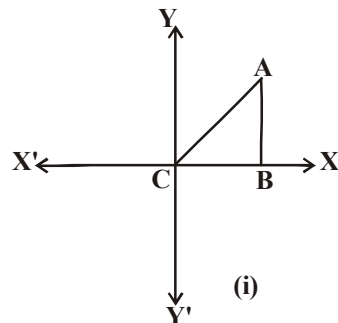
Take a point A on X -axis and B on Y -axis and find area of the triangle AOB . Discuss with your friends how to find the area of the triangle?



Think - Discuss

Let $A(x_1, y_1)$, $B(x_2, y_2)$, $C(x_3, y_3)$ be three points.

Then find the area of the following triangles and discuss with your friends in groups about the area of that triangle.



Area of the triangle

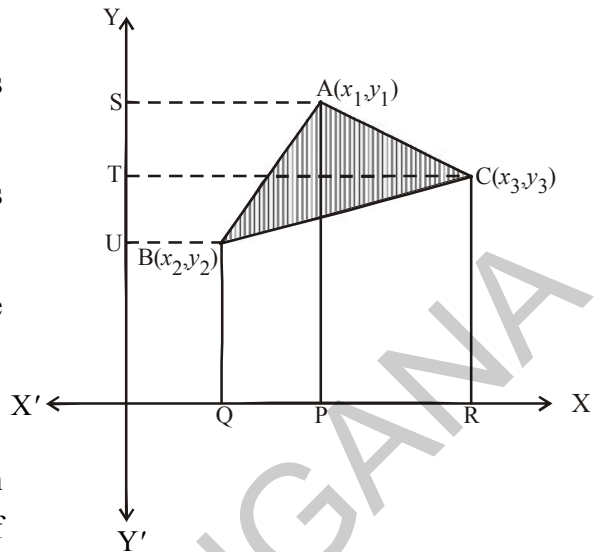
Let ΔABC be any triangle whose vertices are $A(x_1, y_1)$, $B(x_2, y_2)$ and $C(x_3, y_3)$.

Draw AP , BQ and CR perpendiculars from A , B and C respectively to the X -axis.

Clearly $ABQP$, $APRC$ and $BQRC$ are all trapezia.

Now from the figure, it is clear that

Area of ΔABC = area of trapezium $ABQP$ + area of trapezium $APRC$ – area of trapezium $BQRC$



$$\text{Area of } \Delta ABC = \frac{1}{2}(BQ + AP)QP + \frac{1}{2}(AP + CR)PR - \frac{1}{2}(BQ + CR)QR \quad \dots (1)$$

[\because Area of trapezium = $\frac{1}{2}$ (sum of the parallel sides) (distance between them)]

From the figure

$$BQ = y_2, \quad AP = y_1, \quad QP = OP - OQ = x_1 - x_2$$

$$CR = y_3, \quad PR = OR - OP = x_3 - x_1$$

$$QR = OR - OQ = x_3 - x_2$$

Therefore, Area of ΔABC [from (1)]

$$\begin{aligned} &= \frac{1}{2} \left| (y_2 + y_1)(x_1 - x_2) + \frac{1}{2}(y_1 + y_3)(x_3 - x_1) - \frac{1}{2}(y_2 + y_3)(x_3 - x_2) \right| \\ &= \frac{1}{2} |x_1(y_2 - y_3) + x_2(y_3 - y_1) + x_3(y_1 - y_2)| \end{aligned}$$

Thus, the area of ΔABC is

$$\Delta = \frac{1}{2} |x_1(y_2 - y_3) + x_2(y_3 - y_1) + x_3(y_1 - y_2)|$$

Note: As the area cannot be negative, we have taken absolute value.



Let us try some examples.

Example-18. Find the area of a triangle whose vertices are $(1, -1)$, $(-4, 6)$ and $(-3, -5)$.

Solution : The area of the triangle formed by the vertices $A(1, -1)$, $B(-4, 6)$ and $C(-3, -5)$, by using the formula

$$\text{Area of the triangle} = \Delta = \frac{1}{2} |x_1(y_2 - y_3) + x_2(y_3 - y_1) + x_3(y_1 - y_2)|$$

$$\text{Area of } \Delta ABC = \frac{1}{2} |1(6 + 5) + (-4)(-5 + 1) + (-3)(-1 - 6)|$$

$$= \frac{1}{2} |11 + 16 + 21| = 24$$

So, the area of the triangle ΔABC is 24 square units.

Example-19. Find the area of a triangle formed by the points $A(5, 2)$, $B(4, 7)$ and $C(7, -4)$.

Solution : The area of the triangle formed by the vertices $A(5, 2)$, $B(4, 7)$ and $C(7, -4)$ is given by

$$\text{Area of } \Delta ABC = \frac{1}{2} |5(7 + 4) + 4(-4 - 2) + 7(2 - 7)|$$

$$= \frac{1}{2} |55 - 24 - 35| = \left| \frac{-4}{2} \right| = |-2| = 2$$

Therefore, the area of the triangle = 2 square units.



Do This

Find the area of the triangle whose vertices are

1. $(5, 2)$, $(3, -5)$ and $(-5, -1)$
2. $(6, -6)$, $(3, -7)$ and $(3, 3)$

Example-20. If $A(-5, 7)$, $B(-4, -5)$, $C(-1, -6)$ and $D(4, 5)$ are the vertices of a quadrilateral, then, find the area of the quadrilateral ABCD.

Solution : By joining B to D, you will get two triangles ABD, and BCD.

$$\text{The area of } \Delta ABD = \frac{1}{2} |-5(-5 - 5) + (-4)(5 - 7) + 4(7 + 5)|$$

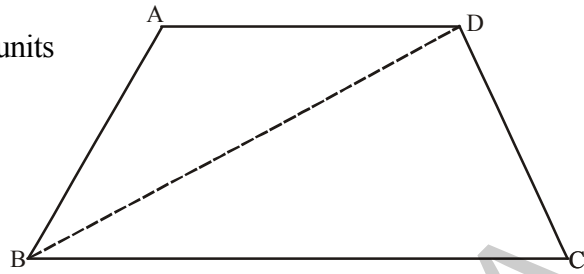


$$= \frac{1}{2}|50 + 8 + 48| = \frac{106}{2} = 53 \text{ square units}$$

Also, the area of $\triangle BCD$

$$= \frac{1}{2}|-4(-6 - 5) - 1(5 + 5) + 4(-5 + 6)|$$

$$= \frac{1}{2}|44 - 10 + 4| = 19 \text{ Square units}$$



So, the area of quadrilateral ABCD = Area of $\triangle ABD$ + area of $\triangle BCD$

$$53 + 19 = 72 \text{ square units.}$$



Try This

Find the area of the square formed by $(0, -1)$, $(2, 1)$, $(0, 3)$ and $(-2, 1)$ as vertices.



Think & Discuss

Find the area of the triangle formed by the following points

- (i) $(2, 0)$, $(1, 2)$, $(-1, 6)$
- (ii) $(3, -1)$, $(5, 0)$, $(1, -2)$
- (iii) $(-1.5, 3)$, $(6, -2)$, $(-3, 4)$

- What do you observe?
- Plot these points on three different graphs. What do you observe now?
- Can we have a triangle with area as zero square units? What does it mean?

7.8.1. Collinearity

We know that the points that lie on the same line are called collinear points.

Suppose the points $A(x_1, y_1)$, $B(x_2, y_2)$ and $C(x_3, y_3)$ are collinear i.e. they are lying on a line. Then, they can not form a triangle. i.e. area of $\triangle ABC$ is zero.

Similarly, when the area of a triangle formed by three points A, B and C is zero, then these three points are said to be collinear points.



Example-21. The points $(3, -2)$, $(-2, 8)$ and $(0, 4)$ are three points in a plane. Show that these points are collinear.

Solution : By using area of the triangle formula

$$\begin{aligned}\Delta &= \frac{1}{2} |3(8 - 4) + (-2)(4 - (-2)) + 0((-2) - 8)| \\ &= \frac{1}{2} |12 - 12| = 0\end{aligned}$$

The area of the triangle is 0. Hence the three points are collinear i.e., they lie on the same line.

Example-22. Find the value of 'b' for which the points $A(1, 2)$, $B(-1, b)$ and $C(-3, -4)$ are collinear.

Solution : Let the given points $A(1, 2)$, $B(-1, b)$ and $C(-3, -4)$

$$\text{Then } x_1 = 1, y_1 = 2; \quad x_2 = -1, y_2 = b; \quad x_3 = -3, y_3 = -4$$

$$\text{We know, area of } \Delta = \frac{1}{2} |x_1(y_2 - y_3) + x_2(y_3 - y_1) + x_3(y_1 - y_2)|$$

$$\text{area of } \Delta ABC = \frac{1}{2} |1(b + 4) + (-1)(-4 - 2) + (-3)(2 - b)| = 0 \quad (\because \text{The given points are collinear})$$

$$|b + 4 + 6 - 6 + 3b| = 0$$

$$|4b + 4| = 0$$

$$4b + 4 = 0$$

$$\therefore b = -1$$



Do This

Verify whether the following points are collinear

(i) $(1, -1), (4, 1), (-2, -3)$

(ii) $(1, -1), (2, 3), (2, 0)$

(iii) $(1, -6), (3, -4), (4, -3)$

7.8.2. Area of a Triangle- 'Heron's Formula'

We know the formula for area of the triangle is $\frac{1}{2} \times \text{base} \times \text{height}$.

Any given triangle may be a right angled triangle, equilateral triangle or an isosceles triangle. How do we calculate its area?



If we know the base and height directly, we apply the above formula to find the area of a triangle.

However, if the height (h) is not known, how do we find its area?

For this Heron, an Ancient Greek mathematician, derived a formula for a triangle whose lengths of sides a , b and c are known. The formula is:

$$A = \sqrt{s(s-a)(s-b)(s-c)}, \text{ where } s = \frac{a+b+c}{2}$$

For example, we find the area of the triangle whose lengths of sides are 12m, 9m, 15m by using Heron's formula we get

$$A = \sqrt{s(s-a)(s-b)(s-c)}, \text{ where } \left(s = \frac{a+b+c}{2} \right)$$

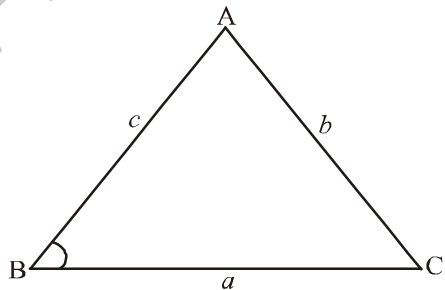
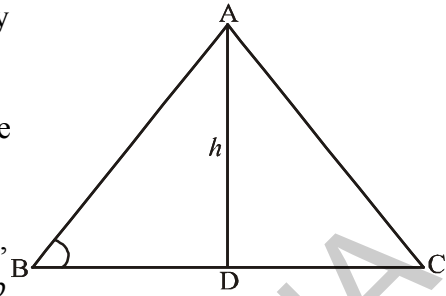
$$s = \frac{12+9+15}{2} = \frac{36}{2} = 18m$$

$$\text{Then } s - a = 18 - 12 = 6m$$

$$s - b = 18 - 9 = 9m$$

$$s - c = 18 - 15 = 3m$$

$$A = \sqrt{18(6)(9)(3)} = \sqrt{2916} = 54 \text{ square meters.}$$



Do This

- (i) Find the area of the triangle the lengths of whose sides are 7m, 24m, 25m (use Heron's Formula).
- (ii) Find the area of the triangle formed by the points (0, 0), (4, 0), (4, 3) by using Heron's formula.





Exercise - 7.3

- Find the area of the triangle whose vertices are
 - $(2, 3)$, $(-1, 0)$, $(2, -4)$
 - $(-5, -1)$, $(3, -5)$, $(5, 2)$
 - $(0, 0)$, $(3, 0)$ and $(0, 2)$
- Find the value of 'K' for which the points are collinear.
 - $(7, -2)$, $(5, 1)$, $(3, K)$
 - $(8, 1)$, $(K, -4)$, $(2, -5)$
 - (K, K) , $(2, 3)$ and $(4, -1)$
- Find the area of the triangle formed by joining the mid-points of the sides of the triangle whose vertices are $(0, -1)$, $(2, 1)$ and $(0, 3)$. Find the ratio of this area to the area of the given triangle.
- Find the area of the quadrilateral whose vertices taken in order are $(-4, -2)$, $(-3, -5)$, $(3, -2)$ and $(2, 3)$.
- Find the area of the triangle formed by the points $(2, 3)$, $(6, 3)$ and $(2, 6)$ by using Heron's formula.

7.9 Straight Lines

Bharadwaj and Meena are trying to find solutions for a linear equation in two variable.

Bharadwaj : Can you find solutions for $2x + 3y = 12$

Meena : Yes, I have found some of them.

x	0	3	6	-3
y	4	2	0	6

In general, $2x + 3y = 12$

$$3y = 12 - 2x$$

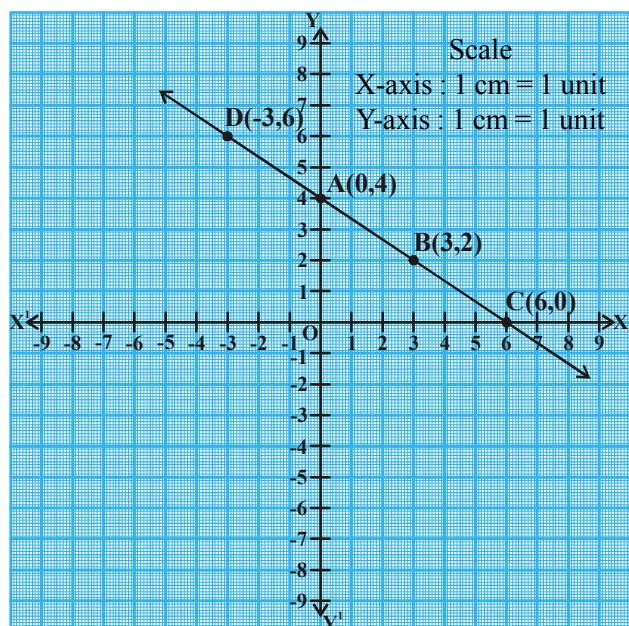
$$y = \frac{12 - 2x}{3}$$

Meena : Can you write these solutions in ordered pairs?

Bharadwaj : Yes, $(0, 4)$, $(3, 2)$, $(6, 0)$, $(-3, 6)$

Meena, can you plot these points on the coordinate plane?

Meena : I have done like this. I have drawn a line joining these points. Observe.



Bharadwaj : What does this figure represent?

Meena : It is a straight line.

Bharadwaj : Can you identify some more points on this line?

Can you help Meena to find some more points on this line?

.....,,,

And in this line, what is \overline{AB} called ?

\overline{AB} is a line segment.



Do This

Plot these points on the coordinate plane and join them:

1. A(1, 2), B(-3, 4), C(7, -1)
2. P(3, -5), Q(5, -1), R(2, 1), S(1, 2)

Which one is a straight line? Which is not? Why?



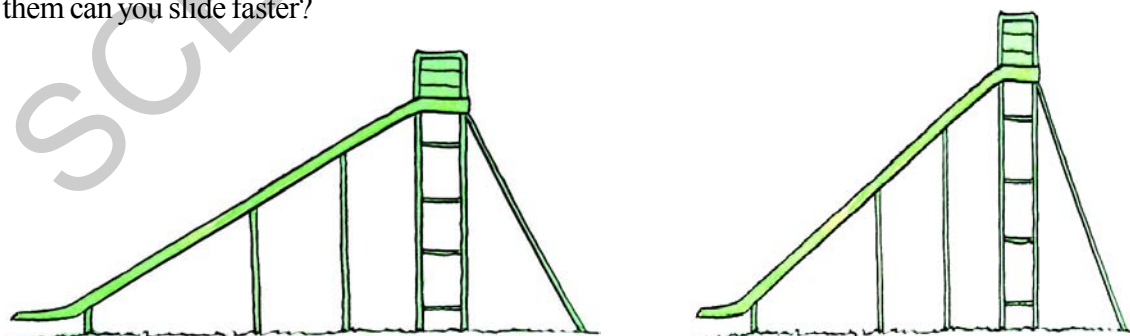
Think & Discuss

Does $y = x + 7$ represent a straight line? Draw the line on the coordinate plane.

At which point does this line intersect X-axis? What is the angle made by this line with X-axis? Discuss with your friends.

7.9.1 Slope of the straight line

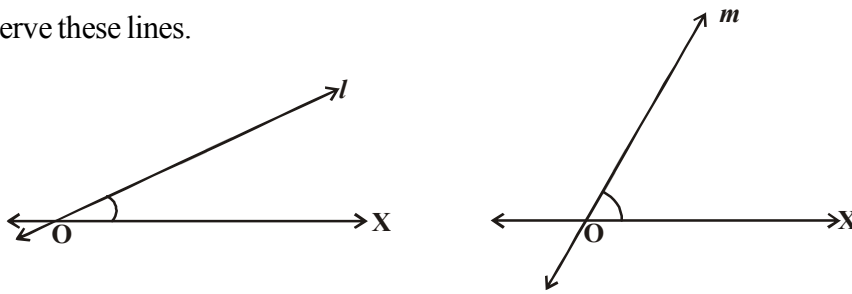
You might have seen a slide in a park. Two slides have been shown here. On which of them can you slide faster?



Obviously your answer will be second. Why?



Observe these lines.



Which line makes greater angle with OX ?

Since, the line “m” makes a greater angle with OX than line ‘l’,

line ‘m’ has a greater “slope” than line ‘l’.

Now can we measure the slope of a line?



Activity

Consider the line given in the figure identify the points on the line and fill the table below.

x coordinate	0	1	2	3	4
y coordinate	0	2	4	6	8

We can observe that y coordinates change when x coordinates change.

When y coordinate increases from $y_1 = 0$ to $y_2 = 2$,

So the change in y is =

Then corresponding change in ‘x’ is = ...

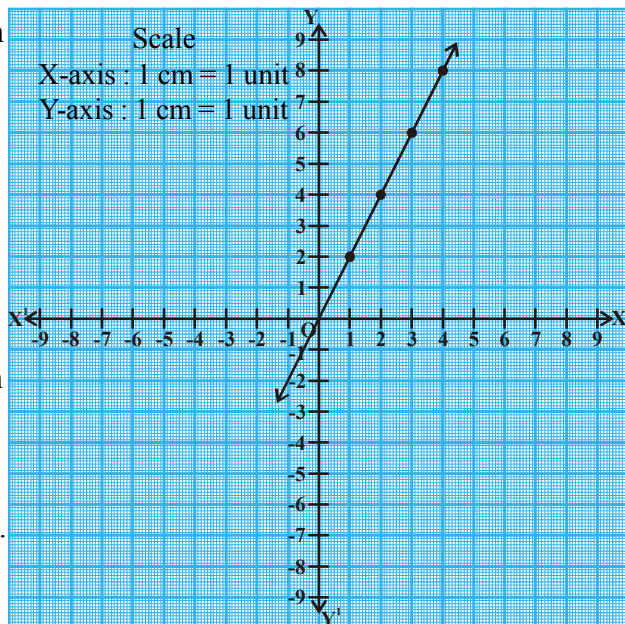
$$\therefore \frac{\text{change in } y}{\text{change in } x} = \dots\dots\dots$$

When y coordinate increases from $y_1 = 2$ to $y_3 = 4$,

the change in y is =

the corresponding change in x is

$$\text{So, } \frac{\text{change in } y}{\text{change in } x} = \dots\dots\dots$$



Then, can you try other points on the line? Choose any two points and fill in the table.

Change in y	Change in x	$\frac{\text{Change in } y}{\text{Change in } x}$
2	1	$\frac{2}{1} = 2$

What do you conclude from the above activity?

Therefore, the ratio of change in y to change in x , on a line, has a relation with the angle made by the line with X-axis. Let us discuss about this relationship now.

7.9.2 Slope of a line joining Two Points

Let $A(x_1, y_1)$ and $B(x_2, y_2)$ be two points on a line ' l ' not parallel to Y-axis as shown in the figure.

The slope of a line = $\frac{\text{change in } y}{\text{change in } x}$

$$\text{Slope of } \overline{AB} = m = \frac{y_2 - y_1}{x_2 - x_1}$$

Slope will be denoted by ' m ' and the line ' l ' makes the angle θ with X-axis.

So, AB line segment makes the same angle θ with AC also.

$$\therefore \tan \theta = \frac{\text{Opposite side of angle } \theta}{\text{adjacent side of angle } \theta}$$

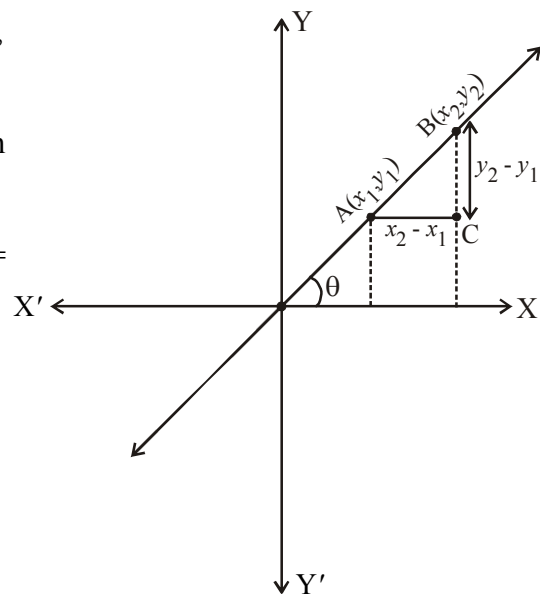
$$\frac{BC}{AC} = \frac{y_2 - y_1}{x_2 - x_1}$$

$$\therefore \tan \theta = \frac{y_2 - y_1}{x_2 - x_1} = m$$

$$\text{Hence } \therefore m = \tan \theta = \frac{y_2 - y_1}{x_2 - x_1}$$

It is the formula to find slope of line segment \overline{AB} which is having end points as (x_1, y_1) , (x_2, y_2) .

If θ is angle made by the line with X-axis, then $m = \tan \theta$.



Example-23. The end points of a line segment are (2, 3) and (4, 5). Find the slope of the line segment.

Solution : The end points of the line segment are (2, 3) and (4, 5), the slope of the line segment is

$$m = \frac{y_2 - y_1}{x_2 - x_1} = \frac{5 - 3}{4 - 2} = \frac{2}{2} = 1$$

Slope of the given line segment is 1.



Do This

Find the slope of \overline{AB} , where

1. A(4, -6), B(7, 2)
2. A(8, -4), B(-4, 8)
3. A(-2, -5), B(1, -7)



Try This

Find the slope of \overline{AB} , where

1. A(2, 1), B(2, 6)
2. A(-4, 2), B(-4, -2)
3. A(-2, 8), B(-2, -2)
4. Justify that the line \overline{AB} formed by points given in the above three examples is parallel to Y-axis. What can you say about the slope in each case? Why?



Think & Discuss

Find the slope of \overline{AB} passing through A(3, 2) and B(-8, 2)

Is the line \overline{AB} parallel to X-axis? Why?

Think and discuss with your friends in groups.

Example-24. Determine x so that 2 is the slope of the line passing through P(2, 5) and Q(x, 3).

Solution : Slope of the line passing through P(2, 5) and Q(x, 3) is 2.

$$\text{Here, } x_1 = 2, \quad y_1 = 5, \quad x_2 = x, \quad y_2 = 3$$

$$\text{Slope of } \overline{PQ} = \frac{y_2 - y_1}{x_2 - x_1} = \frac{3 - 5}{x - 2} = \frac{-2}{x - 2} \Rightarrow \frac{-2}{x - 2} = 2$$

$$\Rightarrow -2 = 2x - 4 \quad \Rightarrow 2x = 2 \quad \Rightarrow x = 1$$





Exercise - 7.4

1. Find the slope of the line passing through the given two points

- (i) $(4, -8)$ and $(5, -2)$
- (ii) $(0, 0)$ and $(\sqrt{3}, 3)$
- (iii) $(2a, 3b)$ and $(a, -b)$
- (iv) $(a, 0)$ and $(0, b)$
- (v) $A(-1.4, -3.7)$ and $B(-2.4, 1.3)$
- (vi) $A(3, -2)$ and $B(-6, -2)$
- (vii) $A\left(-3\frac{1}{2}, 3\right)$ and $B\left(-7, 2\frac{1}{2}\right)$
- (viii) $A(0, 4)$ and $B(4, 0)$



Optional Exercise

[For extensive learning]

- 1. Centre of a circle Q is on the Y -axis. The circle passes through the points $(0, 7)$ and $(0, -1)$. If it intersects the positive X -axis at $(p, 0)$, what is the value of ' p '?
- 2. $\triangle ABC$ is formed by the points $A(2, 3)$, $B(-2, -3)$, $C(4, -3)$. What is the point of intersection of the side BC and the bisector of angle A ?
- 3. The side BC of an equilateral triangle $\triangle ABC$ is parallel to X -axis. Find the slopes of the lines along sides BC , CA and AB .
- 4. Find the centroid of the triangle formed by the line $2x + 3y - 6 = 0$, with the coordinate axes.

Project

- To derive the formula - for obtaining co-ordinates of a point that divides the line segment internally.





What We Have Discussed



1. The distance between two points (x_1, y_1) and (x_2, y_1) on a line parallel to X-axis is $|x_2 - x_1|$.
2. The distance between two points (x_1, y_1) and (x_1, y_2) on a line parallel to Y-axis is $|y_2 - y_1|$.
3. The distance of a point $P(x, y)$ from the origin is $\sqrt{x^2 + y^2}$.
4. The distance between two points $P(x_1, y_1)$ and $Q(x_2, y_2)$ is $\sqrt{(x_2 - x_1)^2 + (y_2 - y_1)^2}$.
5. The coordinates of the point $P(x, y)$ which divides the line segment joining the points $A(x_1, y_1)$ and $B(x_2, y_2)$ internally in the ratio $m_1 : m_2$ are $\left[\frac{m_1 x_2 + m_2 x_1}{m_1 + m_2}, \frac{m_1 y_2 + m_2 y_1}{m_1 + m_2} \right]$.
6. The mid-point of the line segment joining the points (x_1, y_1) and (x_2, y_2) is $\left(\frac{x_1 + x_2}{2}, \frac{y_1 + y_2}{2} \right)$.
7. The centroid of a triangle is the point of concurrence of its medians. Hence, the coordinates of the centroid are $\left(\frac{x_1 + x_2 + x_3}{3}, \frac{y_1 + y_2 + y_3}{3} \right)$, where (x_1, y_1) , (x_2, y_2) and (x_3, y_3) are the vertices of the triangle.
8. The point that divides each median of a triangle in the ratio 2 : 1 is the centroid
9. The area of the triangle formed by the points (x_1, y_1) , (x_2, y_2) and (x_3, y_3) is given by
$$\Delta = \frac{1}{2} |x_1(y_2 - y_3) + x_2(y_3 - y_1) + x_3(y_1 - y_2)|$$
10. Area of a triangle is given by 'Heron's Formula' as
$$A = \sqrt{s(s-a)(s-b)(s-c)}, \quad \text{where } s = \frac{a+b+c}{2}$$

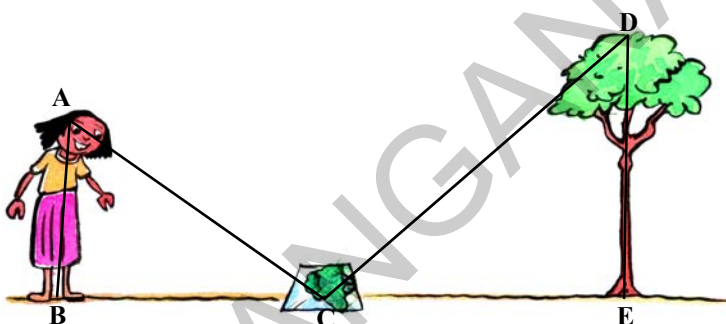
(a, b, c are three sides of ΔABC)
11. Slope of the line containing the points (x_1, y_1) and (x_2, y_2) is $m = \frac{y_2 - y_1}{x_2 - x_1}$ ($x_1 \neq x_2$)





8.1 Introduction

There is a tall tree in the backyard of Snigdha's house. She wants to find out the height of that tree but she is not sure how to find it. Meanwhile, her uncle arrives at home. Snigdha requests her uncle to help her to find the height of the tree. He



thinks for a while and then asks her to bring a mirror. He places it on the ground at a certain distance from the base of the tree. He then asked Snigdha to stand on the other side of the mirror at such a position from where she is able to see the top of the tree in that mirror.

When we draw the figure from (AB) girl to the mirror (C) and mirror to the tree (DE) as above, we observe triangles $\triangle ABC$ and $\triangle DEC$. Now, what can you say about these two triangles? Are they congruent? No, because although they have the same shape their sizes are different. Do you know what we call the geometrical figures which have the same shape, but are not necessarily of the same size? They are called **similar figures**.

How do we know the height of a tree or a mountain? How do we know the distances of far away objects such as Sun or Moon? Do you think these can be measured directly with the help of a measuring tape? The fact is that all these heights and distances have been found out using the idea of indirect measurements which is based on the principle of similarity of figures.

8.2 Similar Figures



(i)



(ii)



(iii)

Observe the object (car) in the figure (i).

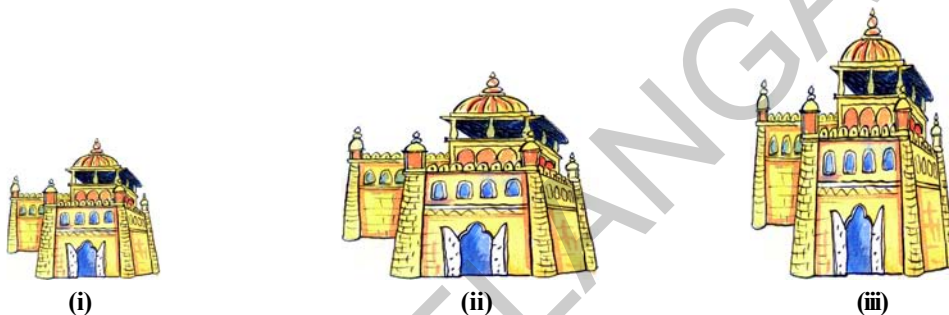
If breadth of the figure is kept the same and the length is doubled, it appears as in fig. (ii).



If the length in fig.(i) is kept the same and its breadth is doubled, it appears as in fig.(iii).

Now, what can you say about fig.(ii) and (iii)? Do they resemble fig.(i)? We find that the figure is distorted. Can you say that they are similar? No, they have same shape, yet they are not similar.

Think what a photographer does when she prints photographs of different sizes from the same film (negative)? You might have heard about stamp size, passport size and post card size photographs. She generally takes a photograph on a small size film, say 35 mm., and then enlarges it into a bigger size, say 45 mm (or 55 mm). We observe that every line segment of the smaller photograph is enlarged in the ratio of 35 : 45 (or 35 : 55). Further, in the two photographs of different sizes, we can see that the corresponding angles are equal. So, the photographs are similar.



Similarly, in geometry, two polygons of the same number of sides are similar if their corresponding angles are equal and their corresponding sides are in the same ratio or proportion.

A polygon in which all sides and angles are equal is called a regular polygon.

The ratio of the corresponding sides is referred to as scale or scale factor (or) representative factor). In real life, blue prints for the construction of a building are prepared using a suitable scale factor.

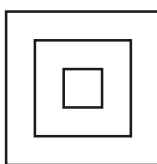
Think and Discuss

Give some more examples from your daily life where scale factor is used.

All regular polygons having the same number of sides are always similar. For example, all squares are similar, all equilateral triangles are similar and so on.

Circles with same radius are congruent and those with different radii are not congruent. But, as all circles have same shape and different size, they are all similar.

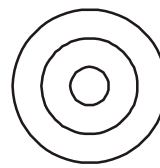
We can say that all congruent figures are similar but all similar figures need not be congruent.



Similar Squares



Similar equilateral triangles



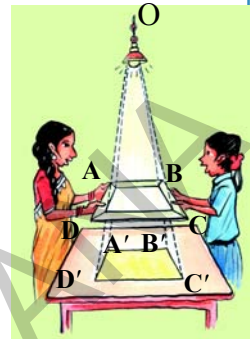
Similar Circles



To understand the similarity of figures more clearly, let us perform the following activity.

Activity

Place a table directly under a lighted bulb, fitted in the ceiling of your classroom. Cut a polygon (say ABCD) from a plane cardboard and suspend it parallel to the ground between the bulb and the table. Then, a shadow of quadrilateral ABCD is cast on the paper arranged on the table. Mark the outline of the shadow as quadrilateral A' B' C' D'.



Now, this quadrilateral A' B' C' D' is enlargement or magnification of quadrilateral ABCD. Further, A' lies on ray OA where 'O' is the bulb, B' on \overrightarrow{OB} , C' on \overrightarrow{OC} and D' on \overrightarrow{OD} . Quadrilaterals ABCD and A' B' C' D' are of the same shape but of different sizes.

A' corresponds to vertex A and we denote it symbolically as $A' \leftrightarrow A$. Similarly $B' \leftrightarrow B$, $C' \leftrightarrow C$ and $D' \leftrightarrow D$.

By actually measuring angles and sides, you can verify

(i) $\angle A = \angle A'$, $\angle B = \angle B'$, $\angle C = \angle C'$, $\angle D = \angle D'$ and

(ii) $\frac{AB}{A'B'} = \frac{BC}{B'C'} = \frac{CD}{C'D'} = \frac{DA}{D'A'}$.

This emphasises that two polygons with the same number of sides are similar if

- (i) All the corresponding angles are equal and
- (ii) All the lengths of the corresponding sides are in the same ratio (or in proportion)

Is a square similar to a rectangle? In both the figures, corresponding angles are equal but their corresponding sides are not in the same ratio. Hence, they are not similar. For similarity of polygons only one of the above two conditions is not sufficient, both have to be satisfied.



Think and Discuss

- Can you say that a square and a rhombus are similar? Discuss with your friends and write reasons.
- Are any two rectangles similar? Justify your answer.





Do This

- Fill in the blanks with similar / not similar.
 - All squares are
 - All equilateral triangles are
 - All isosceles triangles are
 - Two polygons with same number of sides are if their corresponding angles are equal and corresponding sides are equal.
 - Reduced and Enlarged photographs of an object are
 - Rhombus and squares are to each other.
- Write True / False for the following statements.
 - Any two similar figures are congruent.
 - Any two congruent figures are similar.
 - Two polygons are similar if their corresponding angles are equal.
- Give two different examples of pair of
 - Similar figures
 - Non similar figures

8.3 Similarity of Triangles

In the example of finding a tree's height by Snigdha, we had drawn two triangles which showed the property of similarity. We know that, two triangles are similar if their

- Corresponding angles are equal and
- Lengths of the corresponding sides are in the same ratio (in proportion)

In $\triangle ABC$ and $\triangle DEC$ in the introduction,

$$\angle A = \angle D, \angle B = \angle E, \angle ACB = \angle DCE$$

$$\text{Also } \frac{DE}{AB} = \frac{EC}{BC} = \frac{DC}{AC} = K \text{ (scale factor)}$$

thus $\triangle ABC$ is similar to $\triangle DEC$.

Symbolically we write $\triangle ABC \sim \triangle DEC$

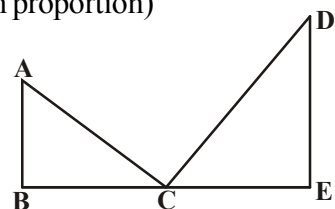
(Symbol ' \sim ' is read as "Is similar to")

As we have stated that K is a scale factor, So

if $K > 1$, we get enlarged figures,

$K = 1$, we get congruent figures and

$K < 1$, we get reduced (or diminished) figures



Further, in triangles $\triangle ABC$ and $\triangle DEC$, corresponding angles are equal. So, they are called equiangular triangles. The ratio of any two corresponding sides in two equiangular triangles is always the same. For proving this, Basic Proportionality theorem is used. This is also known as Thales Theorem.

Basic proportionality theorem?



To understand Basic proportionality theorem or Thales theorem, let us do the following activity.

Activity

Take any ruled paper and draw a triangle on it with base on one of the lines. Several lines will cut the triangle ABC . Select any one line among them and name the points where it meets the sides AB and AC as P and Q .

Find the ratio of $\frac{AP}{PB}$ and $\frac{AQ}{QC}$. What do you observe?

The ratios will be equal. Why? Is it always true? Try for different lines intersecting the triangle. We know that all the lines on a ruled paper are parallel and we observe that every time the ratios are equal.

So in $\triangle ABC$, if $PQ \parallel BC$ then $\frac{AP}{PB} = \frac{AQ}{QC}$.

This result is known as basic proportionality theorem.

8.3.1 Basic Proportionality Theorem (Thales Theorem)

Theorem-8.1 : If a line is drawn parallel to one side of a triangle to intersect the other two sides in distinct points, then the other two sides are divided in the same ratio.

Given : In $\triangle ABC$, $DE \parallel BC$, and DE intersects sides AB and AC at D and E respectively.

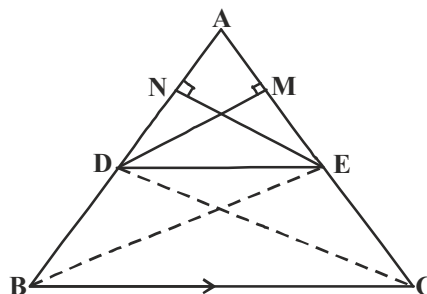
RTP: $\frac{AD}{DB} = \frac{AE}{EC}$

Construction : Join B, E and C, D and then draw

$DM \perp AC$ and $EN \perp AB$.

Proof: Area of $\triangle ADE = \frac{1}{2} \times AD \times EN$

Area of $\triangle BDE = \frac{1}{2} \times BD \times EN$



$$\text{So, } \frac{\text{ar}(\triangle ADE)}{\text{ar}(\triangle BDE)} = \frac{\frac{1}{2} \times AD \times EN}{\frac{1}{2} \times BD \times EN} = \frac{AD}{BD} \quad \dots(1)$$

$$\text{Again, Area of } \triangle ADE = \frac{1}{2} \times AE \times DM$$

$$\text{Area of } \triangle CDE = \frac{1}{2} \times EC \times DM$$

$$\frac{\text{ar}(\triangle ADE)}{\text{ar}(\triangle CDE)} = \frac{\frac{1}{2} \times AE \times DM}{\frac{1}{2} \times EC \times DM} = \frac{AE}{EC} \quad \dots(2)$$



Observe that $\triangle BDE$ and $\triangle CDE$ are on the same base DE and between same parallels BC and DE .

$$\text{So, } \text{ar}(\triangle BDE) = \text{ar}(\triangle CDE) \quad \dots(3)$$

From (1) (2) and (3), we have

$$\frac{AD}{DB} = \frac{AE}{EC}$$

Hence, proved.

Is the converse of the above theorem also true? To examine this, let us perform the following activity.

Activity

Draw an angle XAY in your note book and on ray AX , mark points B_1, B_2, B_3, B_4 and B which are equidistant respectively.

$$AB_1 = B_1B_2 = B_2B_3 = B_3B_4 = B_4B = 1 \text{ cm (say)}$$

Similarly on ray AY , mark points C_1, C_2, C_3, C_4 and C such that

$$AC_1 = C_1C_2 = C_2C_3 = C_3C_4 = C_4C = 2 \text{ cm (say)}$$

Join B_1, C_1 and B, C .

$$\text{Observe that } \frac{AB_1}{B_1B} = \frac{AC_1}{C_1C} = \frac{1}{2} \text{ and } B_1C_1 \parallel BC$$

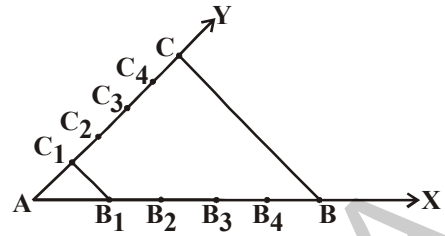


Similarly, joining B_2C_2 , B_3C_3 and B_4C_4 , you see that

$$\frac{AB_2}{B_2B} = \frac{AC_2}{C_2C} = \frac{2}{3}$$

$$\frac{AB_3}{B_3B} = \frac{AC_3}{C_3C} = \frac{3}{2}$$

$$\frac{AB_4}{B_4B} = \frac{AC_4}{C_4C} = \frac{4}{1}$$



check whether $C_1B_1 \parallel C_2B_2 \parallel C_3B_3 \parallel C_4B_4 \parallel CB$?

From this we obtain the following theorem called converse of the Thales theorem

Theorem-8.2 : If a line divides two sides of a triangle in the same ratio, then the line is parallel to the third side.

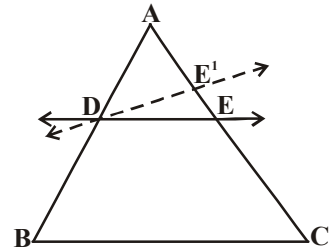
Given : In $\triangle ABC$, a line DE is drawn such that $\frac{AD}{DB} = \frac{AE}{EC}$

RTP : $DE \parallel BC$

Proof : Assume that DE is not parallel to BC then draw the line DE' parallel to BC

$$\text{So } \frac{AD}{DB} = \frac{AE'}{E'C} \quad (\text{why ?})$$

$$\therefore \frac{AE}{EC} = \frac{AE'}{E'C} \quad (\text{why ?})$$



Adding 1 to both sides of the above, you can see that E and E' must coincide (why ?)



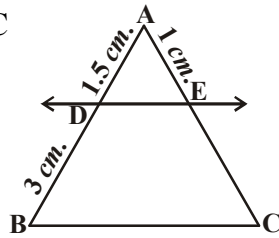
Try This

- In $\triangle PQR$, E and F are points on the sides PQ and PR respectively. For each of the following, state whether $EF \parallel QR$ or not?
 - $PE = 3.9$ cm $EQ = 3$ cm $PF = 3.6$ cm and $FR = 2.4$ cm
 - $PE = 4$ cm, $QE = 4.5$ cm, $PF = 8$ cm and $RF = 9$ cm.
 - $PQ = 1.28$ cm $PR = 2.56$ cm $PE = 1.8$ cm and $PF = 3.6$ cm

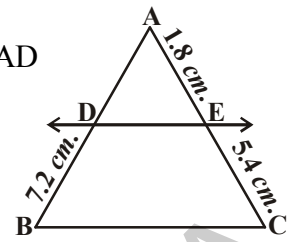


2. In the following figures $DE \parallel BC$.

(i) Find EC



(ii) Find AD



Construction : Division of a line segment (using Thales theorem)

Madhuri drew a line segment. She wants to divide it in the ratio of 3 : 2. She measured it by using a scale and divided it in the required ratio. Meanwhile, her elder sister came. She saw this and suggested Madhuri to divide the line segment in the given ratio without measuring it. Madhuri was puzzled and asked her sister for help to do it. Then her sister explained. You may also do it by the following activity.



Activity

Take a ruled sheet of paper. Number the lines by 1, 2, 3, ... starting with the bottom line numbered '0'.

Take a thick cardboard paper (or file card or chart strip) and place it against the given line segment AB and transfer its length to the card. Let A^1 and B^1 denote the points on the file card corresponding to A and B .

Now, place A^1 on the zeroth line of the lined paper and rotate the card about A^1 until point B^1 falls on the 5th line ($3 + 2$).

Mark the point where the third line touches the file card, by P^1 .

Again, place this card along the given line segment such that A^1 and A , B^1 and B coincides and transfer this point P^1 and denote it with 'P'.

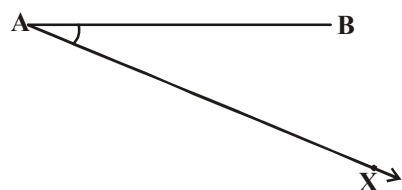
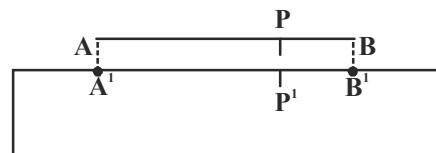
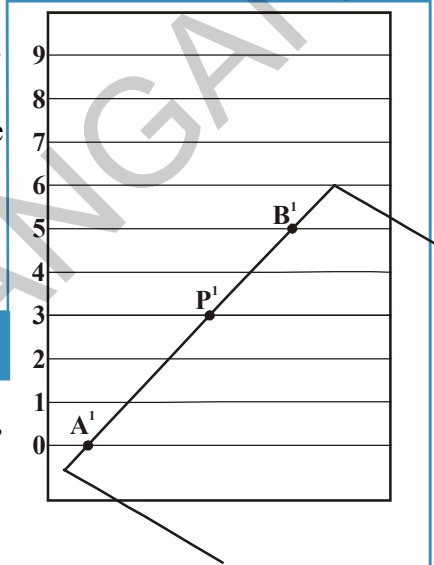
So, 'P' is the required point which divides the given line segment such that A^1 and A , B^1 and B coincides in the ratio 3:2.

Now, let us learn how this construction can be done.

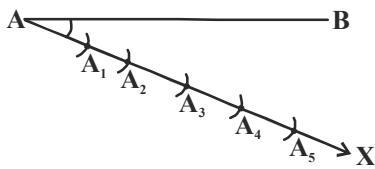
Given a line segment AB . We want to divide it in the ratio $m : n$ (where m and n are both positive integers.) Let us take $m = 3$ and $n = 2$.

Steps :

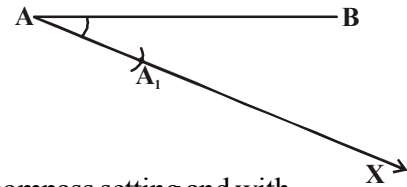
1. Draw a ray AX making an acute angle with AB .



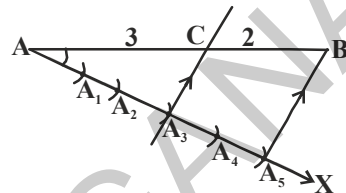
2. With 'A' as centre and with any length draw an arc on ray AX and label the point A₁.



3. Using the same compass setting and with A₁ as centre draw another arc and locate A₂.



4. Like this, locate 5 points ($5 = m + n = 3 + 2$) A₁, A₂, A₃, A₄, A₅ such that $AA_1 = A_1A_2 = A_2A_3 = A_3A_4 = A_4A_5$



5. Join A₅B. Now through point A₃ ($m = 3$) draw a line parallel to A₅B (by making an angle equal to $\angle BA_5A$) intersecting AB at C and observe that $AC : CB = 3 : 2$.

Now, let us solve some example problems using Thales theorem and its converse.

Example-1. In $\triangle ABC$, $DE \parallel BC$, $\frac{AD}{DB} = \frac{3}{5}$ and $AC = 5.6$ cm. Find AE.

Solution : In $\triangle ABC$, $DE \parallel BC$

$$\Rightarrow \frac{AD}{DB} = \frac{AE}{EC} \text{ (by Thales theorem)}$$

$$\text{but } \frac{AD}{DB} = \frac{3}{5} \text{ So } \frac{AE}{EC} = \frac{3}{5}$$

Given $AC = 5.6$ and $AE : EC = 3 : 5$.

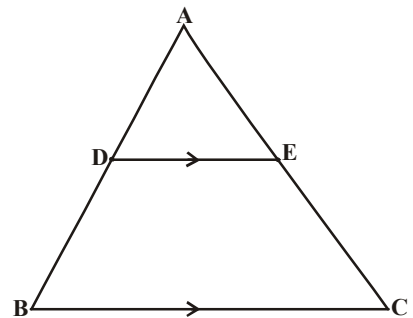
$$\frac{AE}{AC - AE} = \frac{3}{5}$$

$$\frac{AE}{5.6 - AE} = \frac{3}{5} \text{ (cross multiplication)}$$

$$5AE = (3 \times 5.6) - 3AE$$

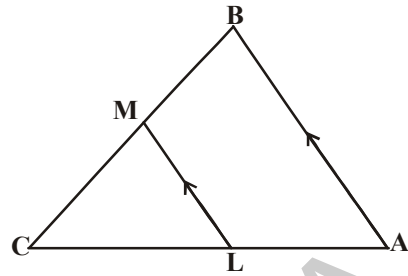
$$8AE = 16.8$$

$$AE = \frac{16.8}{8} = 2.1 \text{ cm.}$$



Example-2. In the given figure, $LM \parallel AB$

$AL = x - 3$, $AC = 2x$, $BM = x - 2$
and $BC = 2x + 3$ find the value of x



Solution : In $\triangle ABC$, $LM \parallel AB$

$$\Rightarrow \frac{AL}{LC} = \frac{BM}{MC} \text{ (by B.P.T)}$$

$$\frac{x-3}{2x-(x-3)} = \frac{x-2}{(2x+3)-(x-2)}$$

$$\frac{x-3}{x+3} = \frac{x-2}{x+5} \text{ (cross multiplication)}$$

$$(x-3)(x+5) = (x-2)(x+3)$$

$$x^2 + 2x - 15 = x^2 + x - 6$$

$$2x - 15 = x - 6 \Rightarrow 2x - x = -6 + 15$$

$$\therefore x = 9$$



Do This

1. In the given figure, what value (s) of x will be make

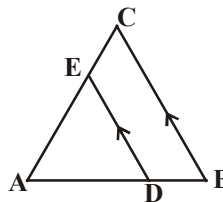
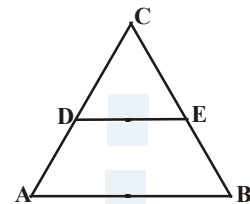
$$AD = 8x + 9, \quad CD = x + 3$$

$$BE = 3x + 4, \quad CE = x.$$

2. In $\triangle ABC$, $DE \parallel BC$. If $AD = x$, $DB = x - 2$,

$$AE = x + 2 \text{ and } EC = x - 1.$$

Then find the value of x .



Example-3. The diagonals of a quadrilateral ABCD intersect each other at point 'O' such that

$$\frac{AO}{BO} = \frac{CO}{DO}. \text{ Prove that ABCD is a trapezium.}$$

Solution : Given : In quadrilateral ABCD, $\frac{AO}{BO} = \frac{CO}{DO}$.

RTP : ABCD is a trapezium.

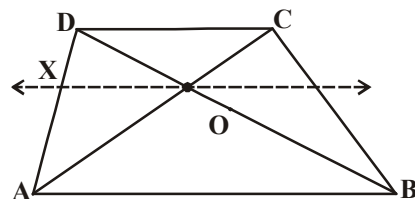
Construction : Through 'O' draw a line parallel to AB which meets DA at X.

Proof : In $\triangle DAB$, $XO \parallel AB$

(by construction)

$$\Rightarrow \frac{DX}{XA} = \frac{DO}{OB}$$

(by basic proportionality theorem)



$$\frac{AX}{XD} = \frac{BO}{OD} \quad \dots (1)$$

but $\frac{AO}{BO} = \frac{CO}{DO}$ (given)

$$\frac{AO}{CO} = \frac{BO}{OD} \quad \dots (2)$$

From (1) and (2)

$$\frac{AX}{XD} = \frac{AO}{CO}$$

In $\triangle ADC$, XO is a line such that $\frac{AX}{XD} = \frac{AO}{OC}$

$\Rightarrow XO \parallel DC$ (by converse of the basic the proportionality theorem)

$\Rightarrow AB \parallel DC$

In quadrilateral ABCD, $AB \parallel DC$

$\Rightarrow ABCD$ is a trapezium (by definition)

Hence proved.

Example-4. In trapezium ABCD, $AB \parallel DC$. E and F are points on non-parallel sides AD and BC respectively such that $EF \parallel AB$. Show that $\frac{AE}{ED} = \frac{BF}{FC}$.

Solution : Let us join A, C to intersect EF at G.

$AB \parallel DC$ and $EF \parallel AB$ (given)

$\Rightarrow EF \parallel DC$ (Lines parallel to the same line are parallel to each other)

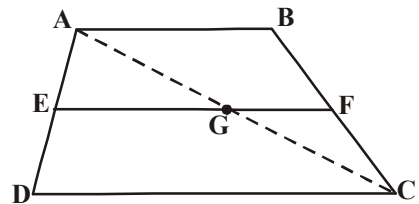
In $\triangle ADC$, $EG \parallel DC$

$$\text{So } \frac{AE}{ED} = \frac{AG}{GC} \text{ (by BPT)} \quad \dots(1)$$

Similarly, In $\triangle CAB$, $GF \parallel AB$

$$\frac{CG}{GA} = \frac{CF}{FB} \text{ (by BPT) i.e., } \frac{AG}{GC} = \frac{BF}{FC} \quad \dots(2)$$

$$\text{From (1) \& (2) } \frac{AE}{ED} = \frac{BF}{FC}.$$



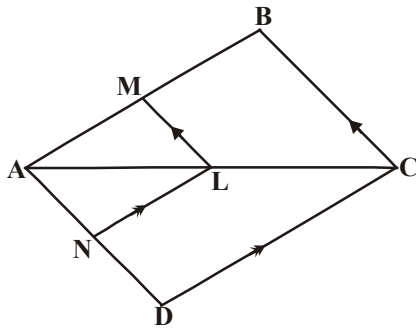
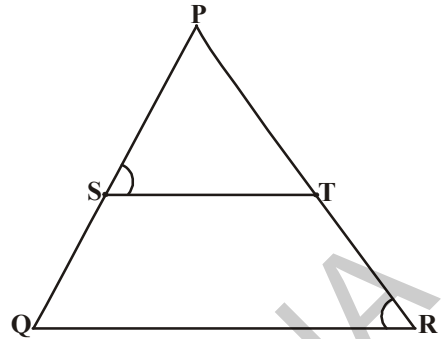


Exercise - 8.1

1. In ΔPQR , ST is a line such that $\frac{PS}{SQ} = \frac{PT}{TR}$ and

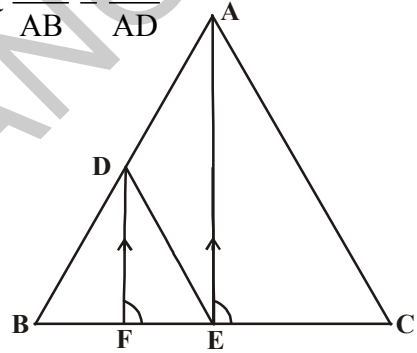
also $\angle TSP = \angle PRQ$.

Prove that ΔPQR is an isosceles triangle.



2. In the given figure, $LM \parallel CB$ and $LN \parallel CD$

Prove that $\frac{AM}{AB} = \frac{AN}{AD}$

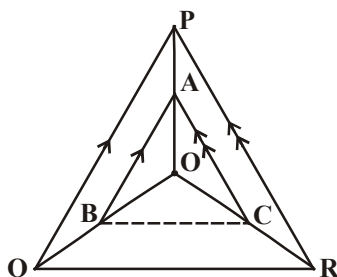
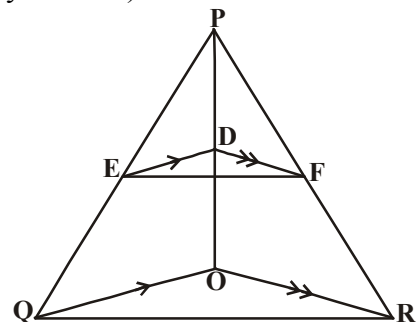


3. In the given figure, $DE \parallel AC$ and $DF \parallel AE$

Prove that $\frac{BF}{FE} = \frac{BE}{EC}$.

4. Prove that a line drawn through the mid-point of one side of a triangle parallel to another side bisects the third side (Using basic proportionality theorem).
 5. Prove that a line segment joining the midpoints of any two sides of a triangle is parallel to the third side. (Using converse of basic proportionality theorem)

6. In the given figure, $DE \parallel OQ$ and $DF \parallel OR$. Show that $EF \parallel QR$.



7. In the adjacent figure, A, B and C are points on OP, OQ and OR respectively such that $AB \parallel PQ$ and $AC \parallel PR$.

Show that $BC \parallel QR$.



8. ABCD is a trapezium in which $AB \parallel DC$ and its diagonals intersect each other at point 'O'.
Show that $\frac{AO}{BO} = \frac{CO}{DO}$.
9. Draw a line segment of length 7.2 cm and divide it in the ratio 5 : 3. Measure the two parts and verify the results.



Think and Discuss

Discuss with your friends that in what way similarity of triangles is different from similarity of other polygons?

8.4 Criteria for Similarity of Triangles

We know that two triangles are similar if corresponding angles are equal and corresponding sides are proportional. For checking the similarity of two triangles, we should check for the equality of corresponding angles and equality of ratios of their corresponding sides. Let us make an attempt to arrive at certain criteria for similarity of two triangles. Let us perform the following activity.



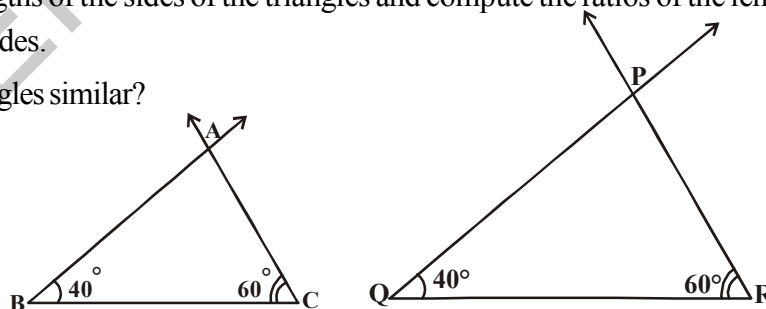
Activity

Use a protractor and ruler to draw two non congruent triangles so that each triangle should have 40° and 60° angle. Check the figures made by you by measuring the third angles of two triangles.

It should be each 80° (why?)

Measure the lengths of the sides of the triangles and compute the ratios of the lengths of the corresponding sides.

Are the triangles similar?



This activity leads us to the following criterion for similarity of two triangles.

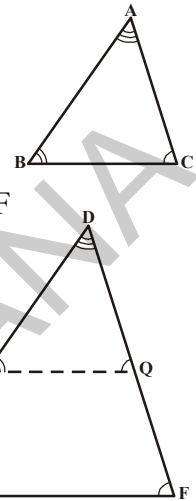


8.4.1 AAA Criterion for Similarity of Triangles

Theorem-8.3 : In two triangles, if corresponding angles are equal, then their corresponding sides are in proportion and hence the triangles are similar.

Given : In triangles ABC and DEF, $\angle A = \angle D$, $\angle B = \angle E$ and $\angle C = \angle F$

$$\text{RTP: } \frac{AB}{DE} = \frac{BC}{EF} = \frac{AC}{DF}$$



Construction : If $AB < DE$ and $AC < DF$, locate points P and Q on DE and DF respectively, such that $AB = DP$ and $AC = DQ$. Join PQ.

Proof: $\triangle ABC \cong \triangle DPQ$ (why?)

This gives $\angle B = \angle P = \angle E$ and $PQ \parallel EF$ (How?)

$$\therefore \frac{DP}{PE} = \frac{DQ}{QF} \text{ (why?) i.e., } \frac{AB}{DE} = \frac{AC}{DF} \text{ (why?)}$$

$$\text{Similarly } \frac{AB}{DE} = \frac{BC}{EF} \text{ So } \frac{AB}{DE} = \frac{BC}{EF} = \frac{AC}{DF}. \text{ Hence proved.}$$

In the above construction, if $AB = DE$ or $AB > DE$, what will you do?

Note : If two angles of a triangle are respectively equal to the two angles of another triangle, then by the angle sum property of a triangle, third angles will also be equal.

So, AA similarity criterion is stated as if two angles of one triangle are respectively equal to the two angles of another triangle, then the two triangles are similar.

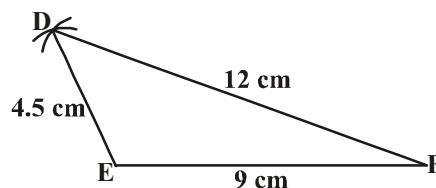
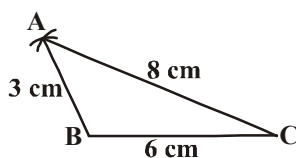
What about the converse of the above statement?

If the sides of a triangle are respectively proportional to the sides of another triangle, is it true that their corresponding angles are equal?

Let us observe it through an activity.

Activity

Draw two triangles ABC and DEF such that $AB = 3$ cm, $BC = 6$ cm, $CA = 8$ cm, $DE = 4.5$ cm, $EF = 9$ cm and $FD = 12$ cm.



So you have $\frac{AB}{DE} = \frac{BC}{EF} = \frac{CA}{FD} = \frac{2}{3}$.

Now, measure the angles of both the triangles. What do you observe? What can you say about the corresponding angles? They are equal, so the triangles are similar. You can verify it for different triangles.

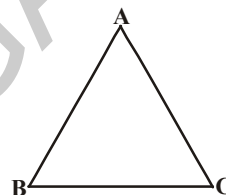
From the above activity, we can write the following criterion for similarity of two triangles.

8.4.2. SSS Criterion for Similarity of Triangles

Theorem-8.4 : In two triangles, if corresponding sides are proportional, then their corresponding angles are equal and hence the triangles are similar.

Given : $\triangle ABC$ and $\triangle DEF$ are such that

$$\frac{AB}{DE} = \frac{BC}{EF} = \frac{CA}{FD} \quad (<1)$$



RTP : $\angle A = \angle D$, $\angle B = \angle E$, $\angle C = \angle F$

Construction : Let $DE > AB$. Locate points P and Q on DE and DF respectively

such that $AB = DP$ and $AC = DQ$. Join PQ.

Proof : $\frac{DP}{PE} = \frac{DQ}{QF}$ and $PQ \parallel EF$ (why ?)

So, $\angle P = \angle E$ and $\angle Q = \angle F$ (why ?)

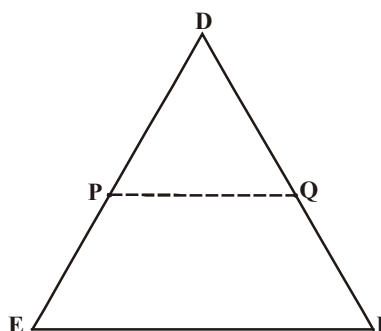
$$\therefore \frac{DP}{DE} = \frac{DQ}{DF} = \frac{PQ}{EF}$$

So, $\frac{DP}{DE} = \frac{DQ}{DF} = \frac{BC}{EF}$ (why ?)

So, $BC = PQ$ (Why ?)

$\triangle ABC \cong \triangle DPQ$ (why ?)

So, $\angle A = \angle D$, $\angle B = \angle E$ and $\angle C = \angle F$ (How ?)



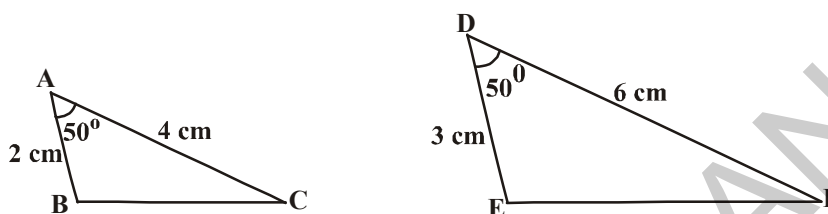
We studied that for similarity of two polygons any one condition is not sufficient. But for the similarity of triangles, there is no need for fulfillment of both the conditions as one automatically implies to the other. Now, let us look for SAS similarity criterion. For this, let us perform the following activity.





Activity

Draw two triangles ABC and DEF such that $AB = 2\text{ cm}$, $\angle A = 50^\circ$, $AC = 4\text{ cm}$;
 $DE = 3\text{ cm}$, $\angle D = 50^\circ$ and $DF = 6\text{ cm}$.



Observe that $\frac{AB}{DE} = \frac{AC}{DF} = \frac{2}{3}$ and $\angle A = \angle D = 50^\circ$.

Now, measure $\angle B$, $\angle C$, $\angle E$, $\angle F$. Also measure BC and EF .

Observe that $\angle B = \angle E$ and $\angle C = \angle F$ also $\frac{BC}{EF} = \frac{2}{3}$.

So, the two triangles are similar. Repeat the same for triangles with different measurements, which gives the following criterion for similarity of triangles.

8.4.3 SAS Criterion for Similarity of Triangles

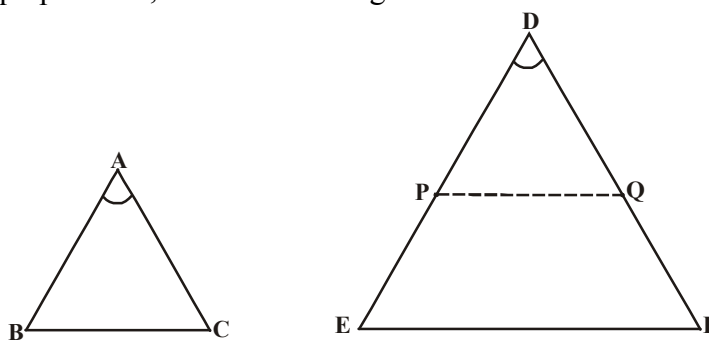
Theorem-8.5 : If one angle of a triangle is equal to one angle of the other triangle and the including sides of these angles are proportional, then the two triangles are similar.

Given : In $\triangle ABC$ and $\triangle DEF$

$$\frac{AB}{DE} = \frac{AC}{DF} (<1) \text{ and}$$

$$\angle A = \angle D$$

RTP: $\triangle ABC \sim \triangle DEF$



Construction : Locate points P and Q on DE and DF respectively such that $AB = DP$ and $AC = DQ$. Join PQ.

Proof : $PQ \parallel EF$ and $\triangle ABC \cong \triangle DPQ$ (How ?)

$$\text{So } \angle A = \angle D, \angle B = \angle P, \angle C = \angle Q$$

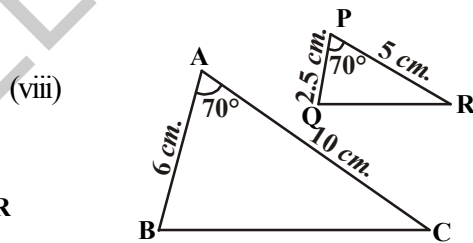
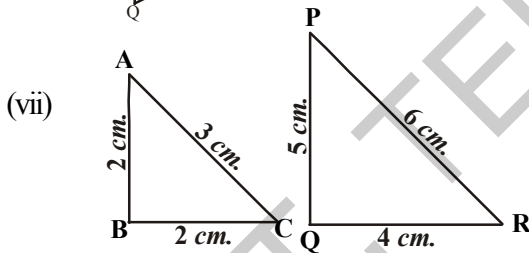
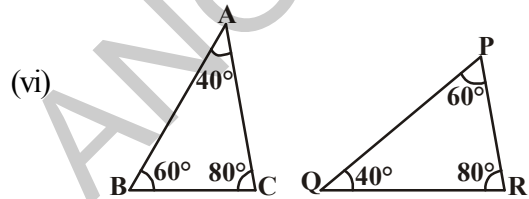
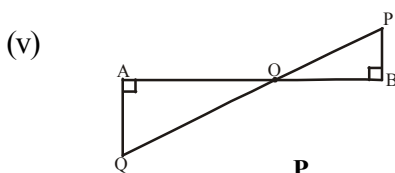
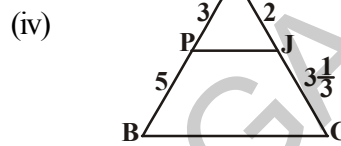
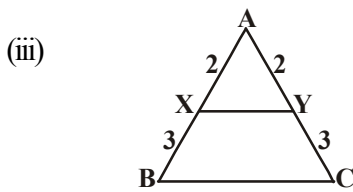
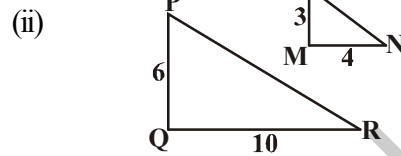
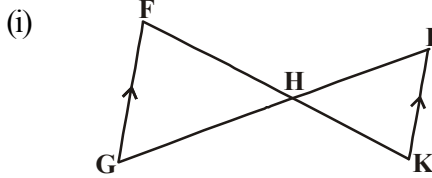
$$\therefore \triangle ABC \sim \triangle DEF \text{ (why ?)}$$



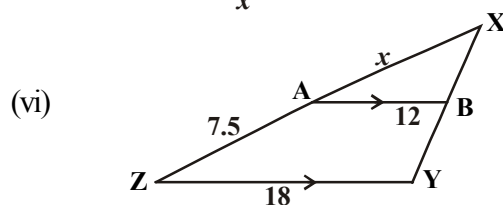
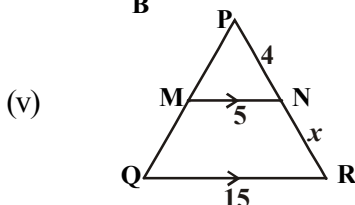
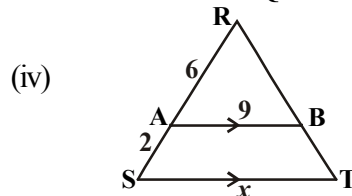
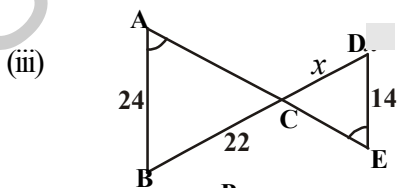
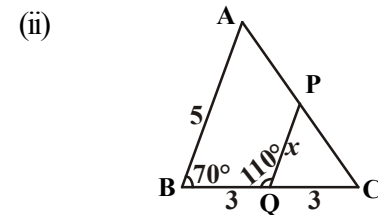
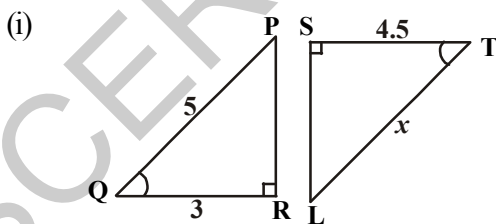


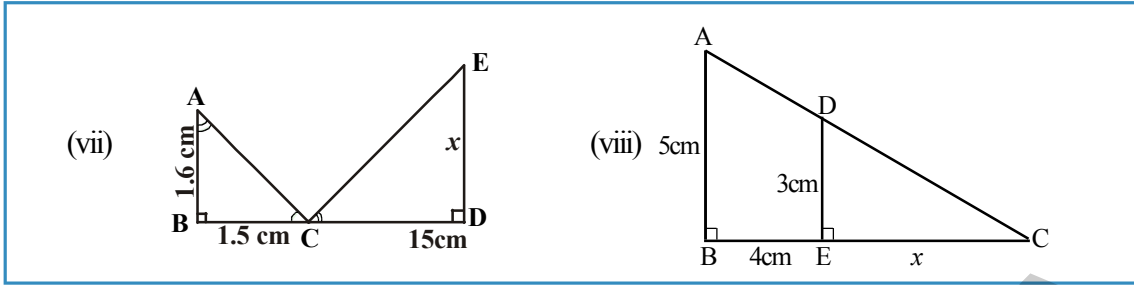
Try This

1. Are triangles formed in each figure similar? If so, name the criterion of similarity. Write the similarity relation in symbolic form.



2. Explain why the following triangles are similar and then find the value of x .

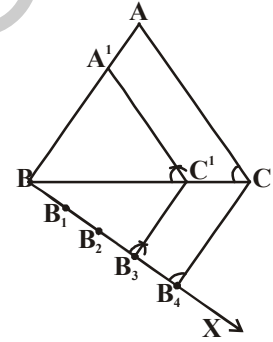




Construction : To construct a triangle similar to a given triangle as per given scale factor.

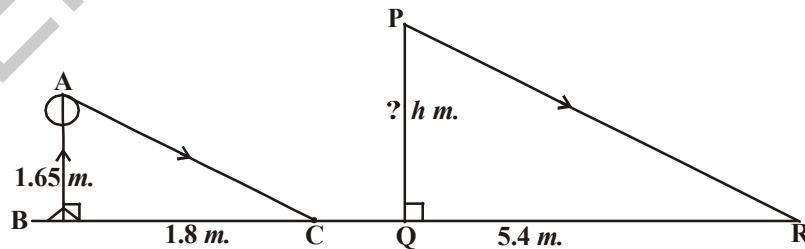
- a) Construct a triangle similar to a given triangle ABC with its sides equal to $\frac{3}{4}$ of corresponding sides of $\triangle ABC$ (scale factor $\frac{3}{4}$)

- Steps :**
1. Draw a ray BX, making an acute angle with BC on the side opposite to vertex A.
 2. Locate 4 points B_1, B_2, B_3 and B_4 on BX so that $BB_1 = B_1B_2 = B_2B_3 = B_3B_4$.
 3. Join B_4C and draw a line through B_3 which is parallel to B_4C intersecting BC at C' .
 4. Draw a line through C' parallel to CA to intersect AB at A' .
- So $\triangle A'BC'$ is the required triangle.



Let us take some examples to illustrate the use of these criteria.

Example-5. A person 1.65m tall casts 1.8m shadow. At the same instance, a lamp post casts a shadow of 5.4 m. Find the height of the lamppost.



Solution: After representing in the form of a figure, In $\triangle ABC$ and $\triangle PQR$

$$\angle B = \angle Q = 90^\circ$$

$$\angle C = \angle R \text{ (} AC \parallel PR, \text{ all sun's rays are parallel at any instance)}$$

$$\triangle ABC \sim \triangle PQR \text{ (by AA similarity)}$$

$$\frac{AB}{PQ} = \frac{BC}{QR} \text{ (corresponding parts of Similar triangles)}$$



$$\frac{1.65}{PQ} = \frac{1.8}{5.4}$$

$$PQ = \frac{1.65 \times 5.4}{1.8} = 4.95 \text{m}$$

The height of the lamp post is 4.95m.

Example-6. A man sees the top of a tower in a mirror which is at a distance of 87.6m from the tower. The mirror is on the ground facing upwards. The man is 0.4m away from the mirror and his height is 1.5m. How tall is the tower?

Solution : After representing in the form of a figure, In $\triangle ABC$ & $\triangle EDC$

$$\angle CBA = \angle EDC = 90^\circ$$

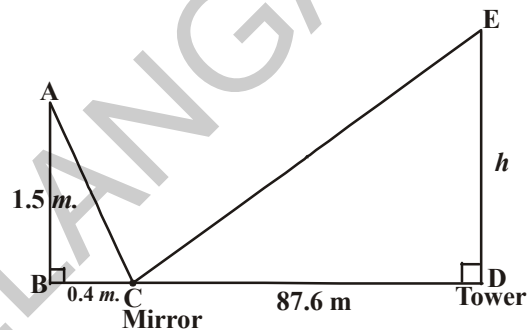
$\angle ACB = \angle DCE$ (Complements of the angle of incidence and angle of reflection are congruent)

$\triangle ABC \sim \triangle EDC$ (by AA similarity)

$$\frac{AB}{ED} = \frac{BC}{CD} \Rightarrow \frac{1.5}{h} = \frac{0.4}{87.6}$$

$$h = \frac{1.5 \times 87.6}{0.4} = 328.5 \text{m}$$

Hence, the height of the tower is 328.5m.



Example7. Gopal is worrying that his neighbour can peep into his living room from the top floor of his house. He has decided raise the height of the fence that is high enough to block the view from his neighbour's top floor window. What should be the height of the fence? The measurements are given in the figure.

Solution : After representing in the form of a figure, In $\triangle ABD$ & $\triangle ACE$

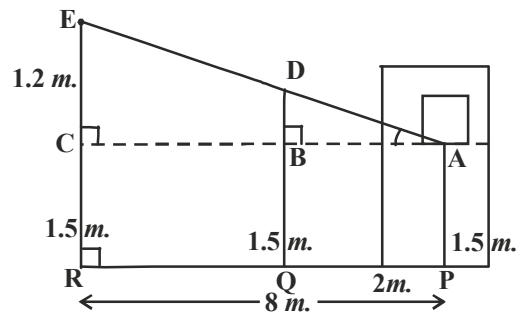
$$\angle B = \angle C = 90^\circ$$

$\angle A = \angle A$ (common angle)

$\triangle ABD \sim \triangle ACE$ (by AA similarity)

$$\frac{AB}{AC} = \frac{BD}{CE} \Rightarrow \frac{2}{8} = \frac{BD}{1.2}$$

$$BD = \frac{2 \times 1.2}{8} = \frac{2.4}{8} = 0.3 \text{m}$$



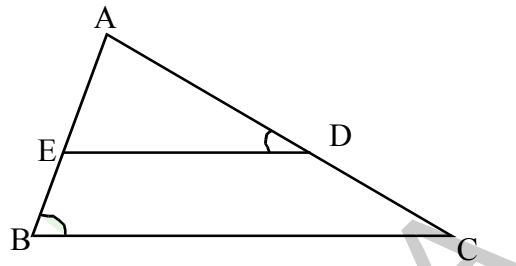
Total height of the fence required is 1.5 m. + 0.3 m. = 1.8m to block the neighbour's view.



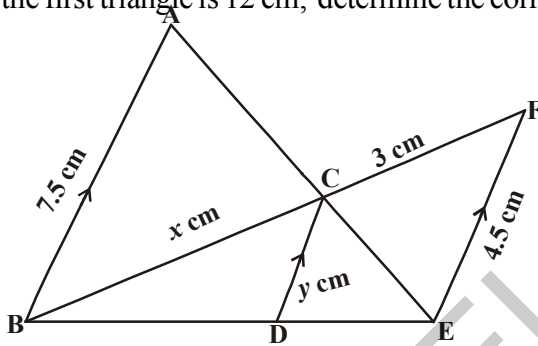


Exercise - 8.2

- In the given figure, $\angle ADE = \angle CBA$
 - Show that $\triangle ABC \sim \triangle ADE$
 - If $AD = 3.8$ cm, $AE = 3.6$ cm, $BE = 2.1$ cm and $BC = 4.2$ cm, find DE .

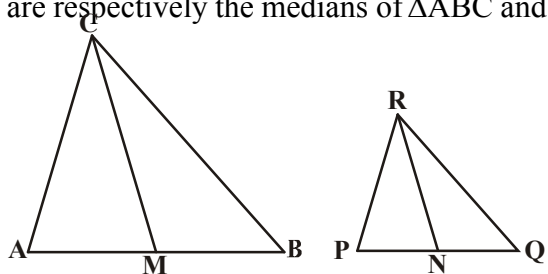


- The perimeters of two similar triangles are 30 cm and 20 cm respectively. If one side of the first triangle is 12 cm, determine the corresponding side of the second triangle.



- In the given figure, $AB \parallel CD \parallel EF$. given that $AB = 7.5$ cm, $DC = y$ cm, $EF = 4.5$ cm, $BC = x$ cm and $CF = 3$ cm find the values of x and y .

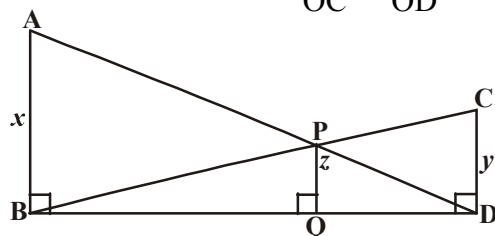
- A girl of height 90 cm is walking away from the base of a lamp post at a speed of 1.2 m/sec. If the lamp post is 3.6m above the ground, find the length of her shadow after 4 seconds.
- Given that $\triangle ABC \sim \triangle PQR$, CM and RN are respectively the medians of $\triangle ABC$ and $\triangle PQR$. Prove that
 - $\triangle AMC \sim \triangle PNR$
 - $\frac{CM}{RN} = \frac{AB}{PQ}$
 - $\triangle CMB \sim \triangle RNQ$



- Diagonals AC and BD of a trapezium $ABCD$ with $AB \parallel DC$ intersect each other at the point 'O'. Using the criterion of similarity for two triangles, show that $\frac{OA}{OC} = \frac{OB}{OD}$.

- AB, CD, PQ are perpendicular to BD .
If $AB = x$, $CD = y$ and $PQ = z$

prove that $\frac{1}{x} + \frac{1}{y} = \frac{1}{z}$.



8. A flag pole 4m tall casts a 6 m shadow. At the same time, a nearby building casts a shadow of 24m. How tall is the building ?
9. CD and GH are respectively the bisectors of $\angle ACB$ and $\angle FGE$ such that D and H lie on sides AB and FE of $\triangle ABC$ and $\triangle FEG$ respectively. If $\triangle ABC \sim \triangle FEG$, then show that
 - (i) $\frac{CD}{GH} = \frac{AC}{FG}$
 - (ii) $\triangle DCB \sim \triangle HGE$
 - (iii) $\triangle DCA \sim \triangle HGF$
10. AX and DY are altitudes of two similar triangles $\triangle ABC$ and $\triangle DEF$. Prove that $AX : DY = AB : DE$.
11. Construct a $\triangle ABC$ with your own measurements. Construct another triangle similar to $\triangle ABC$, with its sides equal to $\frac{5}{3}$ of the corresponding sides of the triangle ABC.
12. Construct a triangle of sides 4cm, 5 cm and 6 cm. Then, construct a triangle similar to it, whose sides are $\frac{2}{3}$ of the corresponding sides of the first triangle.
13. Construct an isosceles triangle whose base is 8cm and altitude is 4 cm. Then, draw another triangle whose sides are $1\frac{1}{2}$ times the corresponding sides of the isosceles triangle.

8.5 Areas of Similar Triangles

For two similar triangles, ratios of their corresponding sides is the same. Do you think there is any relationship between the ratios of their areas and the ratios of their corresponding sides ? Let us do the following activity to understand this.



Activity

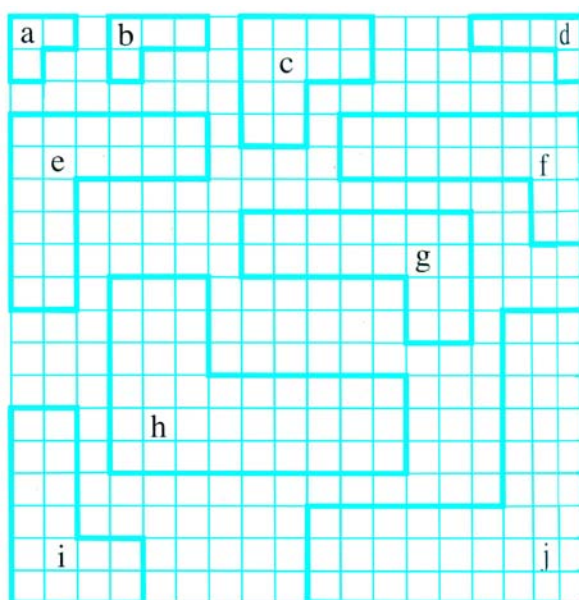
Make a list of pairs of similar polygons in this figure.

Find

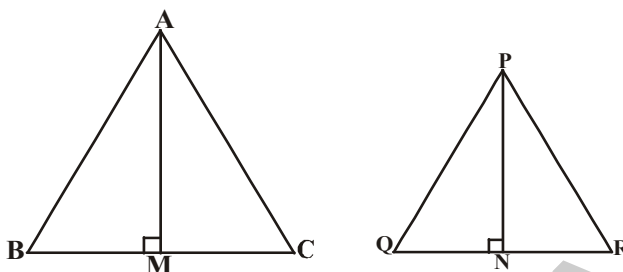
- (i) the ratio of similarity (scale factor) and
- (ii) the ratio of areas.

You will observe that ratio of areas is the square of the ratio of their corresponding sides.

Let us prove it like a theorem.



Theorem-8.6 : The ratio of the areas of two similar triangles is equal to the ratio of the squares of their corresponding sides.



Given : $\Delta ABC \sim \Delta PQR$

RTP :
$$\frac{\text{ar}(\Delta ABC)}{\text{ar}(\Delta PQR)} = \left(\frac{AB}{PQ}\right)^2 = \left(\frac{BC}{QR}\right)^2 = \left(\frac{CA}{RP}\right)^2.$$

Construction : Draw $AM \perp BC$ and $PN \perp QR$.

Proof :
$$\frac{\text{ar}(\Delta ABC)}{\text{ar}(\Delta PQR)} = \frac{\frac{1}{2} \times BC \times AM}{\frac{1}{2} \times QR \times PN} = \frac{BC \times AM}{QR \times PN} \quad \dots(1)$$

In ΔABM & ΔPQN

$$\angle B = \angle Q (\because \Delta ABC \sim \Delta PQR)$$

$$\angle M = \angle N = 90^\circ$$

$\therefore \Delta ABM \sim \Delta PQN$ (by AA similarity)

$$\frac{AM}{PN} = \frac{AB}{PQ} \quad \dots(2)$$

Also $\Delta ABC \sim \Delta PQR$ (given)

$$\frac{AB}{PQ} = \frac{BC}{QR} = \frac{AC}{PR} \quad \dots(3)$$

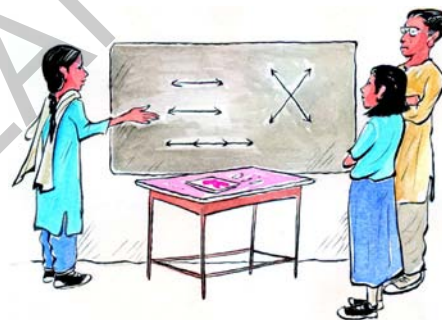
$$\begin{aligned} \therefore \frac{\text{ar}(\Delta ABC)}{\text{ar}(\Delta PQR)} &= \frac{AB}{PQ} \times \frac{AB}{PQ} && \text{from (1), (2) and (3)} \\ &= \left(\frac{AB}{PQ}\right)^2. \end{aligned}$$

Now by using (3), we get

$$\frac{\text{ar}(\Delta ABC)}{\text{ar}(\Delta PQR)} = \left(\frac{AB}{PQ}\right)^2 = \left(\frac{BC}{QR}\right)^2 = \left(\frac{AC}{PR}\right)^2$$

Hence proved.

Now let us see some examples.



Example-8. Prove that if the areas of two similar triangles are equal, then they are congruent.

Solution : $\Delta ABC \sim \Delta PQR$

$$\text{So } \frac{\text{ar}(\Delta ABC)}{\text{ar}(\Delta PQR)} = \left(\frac{AB}{PQ}\right)^2 = \left(\frac{BC}{QR}\right)^2 = \left(\frac{AC}{PR}\right)^2$$

$$\text{But } \frac{\text{ar}(\Delta ABC)}{\text{ar}(\Delta PQR)} = 1 \quad (\because \text{areas are equal})$$

$$\left(\frac{AB}{PQ}\right)^2 = \left(\frac{BC}{QR}\right)^2 = \left(\frac{AC}{PR}\right)^2 = 1$$

$$\text{So } AB^2 = PQ^2$$

$$BC^2 = QR^2$$

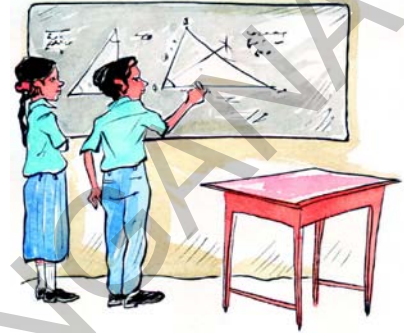
$$AC^2 = PR^2$$

From which we get $AB = PQ$

$$BC = QR$$

$$AC = PR$$

$\therefore \Delta ABC \cong \Delta PQR$ (by SSS congruency)



Example-9. $\Delta ABC \sim \Delta DEF$ and their areas are respectively 64cm^2 and 121cm^2 .

If $EF = 15.4\text{ cm.}$, then find BC .

$$\text{Solution : } \frac{\text{ar}(\Delta ABC)}{\text{ar}(\Delta DEF)} = \left(\frac{BC}{EF}\right)^2$$

$$\frac{64}{121} = \left(\frac{BC}{15.4}\right)^2$$

$$\frac{8}{11} = \frac{BC}{15.4} \Rightarrow BC = \frac{8 \times 15.4}{11} = 11.2\text{cm.}$$

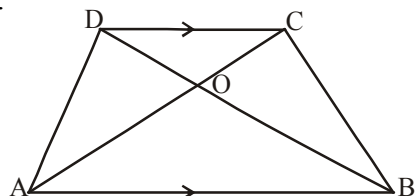
Example-10. In a trapezium $ABCD$ with $AB \parallel DC$, diagonals intersect each other at the point 'O'. If $AB = 2CD$, find the ratio of areas of triangles AOB and COD .

Solution : In trapezium $ABCD$, $AB \parallel DC$ also $AB = 2CD$.

In ΔAOB and ΔCOD

$$\angle AOB = \angle COD \text{ (vertically opposite angles)}$$

$$\angle BOA = \angle DCO \text{ (alternate interior angles)}$$



$\triangle AOB \sim \triangle COD$ (by AA similarity)

$$\frac{\text{ar}(\triangle AOB)}{\text{ar}(\triangle COD)} = \frac{AB^2}{DC^2}$$
$$= \frac{(2DC)^2}{(DC)^2} = \frac{4}{1}$$

$\therefore \text{ar}(\triangle AOB) : \text{ar}(\triangle COD) = 4 : 1.$



Exercise - 8.3

1. D, E, F are mid points of sides BC, CA, AB of $\triangle ABC$. Find the ratio of areas of $\triangle DEF$ and $\triangle ABC$.
2. In $\triangle ABC$, $XY \parallel AC$ and XY divides the triangle into two parts of equal area. Find $\frac{AX}{XB}$.
3. Prove that the ratio of areas of two similar triangles is equal to the square of the ratio of their corresponding medians.
4. $\triangle ABC \sim \triangle DEF$. $BC = 3\text{cm}$, $EF = 4\text{cm}$ and area of $\triangle ABC = 54\text{ cm}^2$. Determine the area of $\triangle DEF$.
5. ABC is a triangle and PQ is a straight line meeting AB in P and AC in Q. If $AP = 1\text{ cm}$, $BP = 3\text{cm}$, $AQ = 1.5\text{ cm}$ and $CQ = 4.5\text{ cm}$, prove that
area of $\triangle APQ = \frac{1}{16}$ (area of $\triangle ABC$).
6. The areas of two similar triangles are 81 cm^2 and 49 cm^2 respectively. If the altitude of the bigger triangle is 4.5 cm . Find the corresponding altitude of the smaller triangle.

8.6 Pythagoras Theorem

You are familiar with the Pythagoras theorem. You had verified this theorem through some activities. Now, we shall prove this theorem using the concept of similarity of triangles. For this, we make use of the following result.

Theorem-8.7 : If a perpendicular is drawn from the vertex of the right angle of a right triangle to the hypotenuse, then the triangles on both sides of the perpendicular are similar to the whole triangle and to each other.



Proof: ABC is a right triangle, right angled at B. Let BD be the perpendicular to hypotenuse AC.

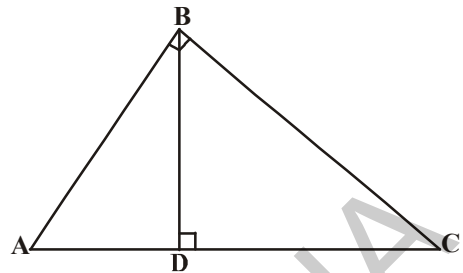
In $\triangle ADB$ and $\triangle ABC$

$$\angle A = \angle A$$

and $\angle BDA = \angle ABC$ (why?)

So $\triangle ADB \sim \triangle ABC$ (how?) ... (1)

Similarly, $\triangle BDC \sim \triangle ABC$ (how?) ... (2)



So from (1) and (2), triangles on both sides of the perpendicular BD are similar to the triangle ABC.

Also since $\triangle ADB \sim \triangle ABC$

$$\triangle BDC \sim \triangle ABC$$

So $\triangle ADB \sim \triangle BDC$ (Transitive Property)

This leads to the following theorem.



Think and Discuss

For a right angled triangle with integer sides atleast one of its measurements must be an even number. Why? Discuss this with your friends and teachers.

8.6.1 Baudhayana Theorem (Pythagoras Theorem)

Theorem-8.8 : In a right triangle, the square of length of the hypotenuse is equal to the sum of the squares of lengths of the other two sides.

Given: $\triangle ABC$ is a right triangle right angled at B.

RTP : $AC^2 = AB^2 + BC^2$

Construction : Draw $BD \perp AC$.

Proof : $\triangle ADB \sim \triangle ABC$

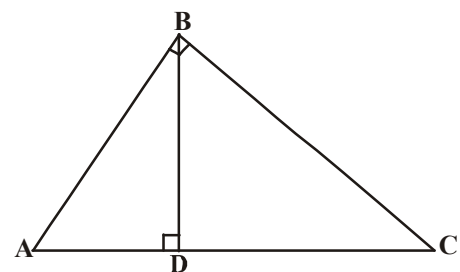
$$\Rightarrow \frac{AD}{AB} = \frac{AB}{AC} \quad \text{(sides are proportional)}$$

$$AD \cdot AC = AB^2 \quad \dots(1)$$

Also, $\triangle BDC \sim \triangle ABC$

$$\Rightarrow \frac{CD}{BC} = \frac{BC}{AC}$$

$$CD \cdot AC = BC^2 \quad \dots(2)$$



On adding (1) & (2)

$$AD \cdot AC + CD \cdot AC = AB^2 + BC^2$$

$$AC(AD + CD) = AB^2 + BC^2$$

$$AC \cdot AC = AB^2 + BC^2$$

$$\boxed{AC^2 = AB^2 + BC^2}$$



The above theorem was earlier given by an ancient Indian mathematician **Baudhayana** (about 800 BC) in the following form.

“The diagonal of a rectangle produces by itself the same area as produced by its both sides (i.e. length and breadth).” So, this theorem is also referred to as the Baudhayana theorem.

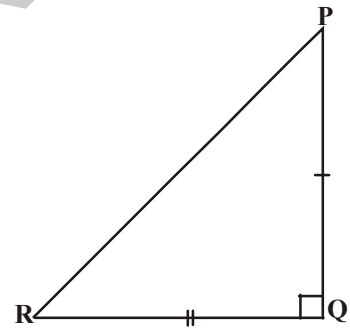
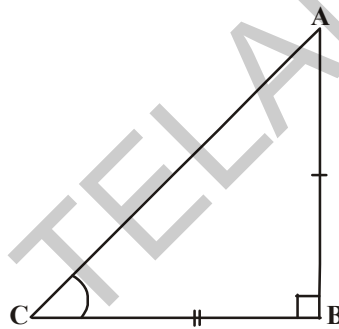
What about the converse of the above theorem? We prove it also like a theorem.

Theorem-8.9 : In a triangle, if square of the length of one side is equal to the sum of squares of the lengths of the other two sides, then the angle opposite to the first side is a right angle and the triangle is a right angled triangle.

Given : In $\triangle ABC$, $AC^2 = AB^2 + BC^2$

RTP : $\angle B = 90^\circ$.

Construction : Construct a right angled triangle $\triangle PQR$ right angled at Q such that $PQ = AB$ and $QR = BC$.



Proof : In $\triangle PQR$,

$$PR^2 = PQ^2 + QR^2 \text{ (Pythagorean theorem as } \angle Q = 90^\circ)$$

$$PR^2 = AB^2 + BC^2 \text{ (by construction) } \dots(1)$$

$$\text{but } AC^2 = AB^2 + BC^2 \text{ (given) } \dots(2)$$

$$\therefore AC = PR \text{ from (1) \& (2)}$$

Now In $\triangle ABC$ and $\triangle PQR$

$$AB = PQ \text{ (by construction)}$$

$$BC = QR \text{ (by construction)}$$

$$AC = PR \text{ (proved)}$$

$$\therefore \triangle ABC \cong \triangle PQR \text{ (by SSS congruency)}$$

$$\therefore \angle B = \angle Q \text{ (by cpct)}$$

$$\text{but } \angle Q = 90^\circ \text{ (by construction)}$$

$$\therefore \angle B = 90^\circ.$$

Hence, proved.



Now let us take some examples.

Example-11. A ladder 25m long reaches a window of a building 20m above the ground. Determine the distance from the foot of the ladder to the building.

Solution : In $\triangle ABC$, $\angle C = 90^\circ$

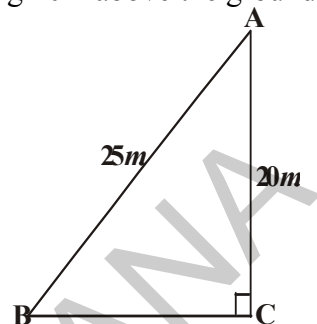
$$\Rightarrow AB^2 = AC^2 + BC^2 \text{ (by Pythagorean theorem)}$$

$$25^2 = 20^2 + BC^2$$

$$BC^2 = 625 - 400 = 225$$

$$BC = \sqrt{225} = 15\text{m}$$

Hence, the foot of the ladder is at a distance of 15m from the building.



Example-12. BL and CM are medians of a triangle ABC right angled at A.

Prove that $4(BL^2 + CM^2) = 5BC^2$.

Solution : BL and CM are medians of $\triangle ABC$ in which $\angle A = 90^\circ$.

In $\triangle ABC$, $BC^2 = AB^2 + AC^2$ (Pythagorean theorem ... (1))

Similarly, in $\triangle ABL$, $BL^2 = AL^2 + AB^2$

So, $BL^2 = \left(\frac{AC}{2}\right)^2 + AB^2$ (\because L is the midpoint of AC)

$$BL^2 = \frac{AC^2}{4} + AB^2$$

$$\therefore 4BL^2 = AC^2 + 4AB^2$$

Similarly, in $\triangle CMA$, $CM^2 = AC^2 + AM^2$

$$CM^2 = AC^2 + \left(\frac{AB}{2}\right)^2 \text{ (\because M is the mid point of AB)}$$

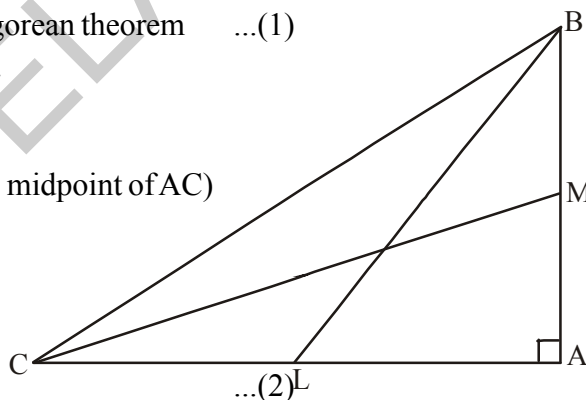
$$CM^2 = AC^2 + \frac{AB^2}{4}$$

$$4CM^2 = 4AC^2 + AB^2 \quad \dots(3)$$

On adding (2) and (3), we get

$$4(BL^2 + CM^2) = 5(AC^2 + AB^2)$$

$$\therefore 4(BL^2 + CM^2) = 5BC^2 \text{ from (1).}$$



Example-13. 'O' is any point inside a rectangle ABCD. Prove that $OB^2 + OD^2 = OA^2 + OC^2$

Solution : Through 'O' draw a line parallel to BC which intersect AB at P and DC at Q.

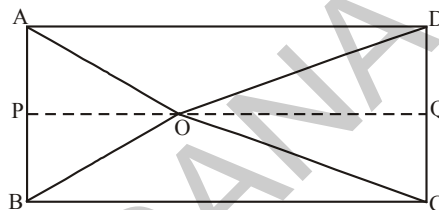
Now, $PQ \parallel BC$

$\therefore PQ \perp AB$ & $PQ \perp DC$ ($\because \angle B = \angle C = 90^\circ$)

So, $\angle BPQ = 90^\circ$ & $\angle CQP = 90^\circ$

\therefore BPQC and APQD are both rectangles.

Now, from $\triangle OPB$, $OB^2 = BP^2 + OP^2$... (1)



Similarly, from $\triangle OQD$, we have $OD^2 = OQ^2 + DQ^2$... (2)

From $\triangle OQC$, we have $OC^2 = OQ^2 + CQ^2$... (3)

and from $\triangle OAP$, $OA^2 = AP^2 + OP^2$

Adding (1) & (2)

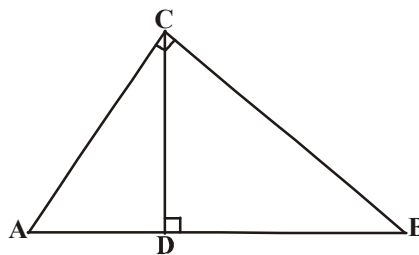
$$\begin{aligned} OB^2 + OD^2 &= BP^2 + OP^2 + OQ^2 + DQ^2 \\ &= CQ^2 + OP^2 + OQ^2 + AP^2 && (\because BP = CQ \text{ and } DQ = AP) \\ &= CQ^2 + OQ^2 + OP^2 + AP^2 \\ &= OC^2 + OA^2 \text{ (from (3) \& (4))} \end{aligned}$$



Do This

1. In $\triangle ACB$, $\angle C = 90^\circ$ and $CD \perp AB$

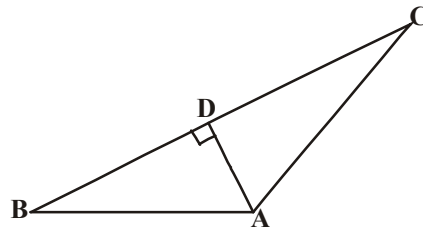
Prove that $\frac{BC^2}{AC^2} = \frac{BD}{AD}$.



2. A ladder 15m long reaches a window which is 9 m above the ground on one side of a street. Keeping its foot at the same point, the ladder is turned to other side of the street to reach a window 12m high. Find the width of the street.



3. In the given fig. if $AD \perp BC$
 Prove that $AB^2 + CD^2 = BD^2 + AC^2$.



Example-14. The hypotenuse of a right triangle is 6m more than twice of the shortest side. If the third side is 2 m. less than the hypotenuse, then find the sides of the triangle.

Solution : Let the shortest side be x m.

Then hypotenuse = $(2x + 6)$ m and third side = $(2x + 4)$ m.

By Pythagoras theorem, we have

$$(2x + 6)^2 = x^2 + (2x + 4)^2$$

$$4x^2 + 24x + 36 = x^2 + 4x^2 + 16x + 16$$

$$x^2 - 8x - 20 = 0$$

$$(x - 10)(x + 2) = 0$$

$$x = 10 \text{ or } x = -2$$

But, x can't be negative as it is a side of a triangle

$$\therefore x = 10$$

Hence, the sides of the triangle are 10m, 26m and 24m.



Example-15. ABC is a right triangle right angled at C. Let $BC = a$, $CA = b$, $AB = c$ and let p be the length of perpendicular from C on AB. Prove that (i) $pc = ab$ (ii) $\frac{1}{p^2} = \frac{1}{a^2} + \frac{1}{b^2}$.

Solution :

- (i) $CD \perp AB$ and $CD = p$.

$$\text{Area of } \triangle ABC = \frac{1}{2} \times AB \times CD$$

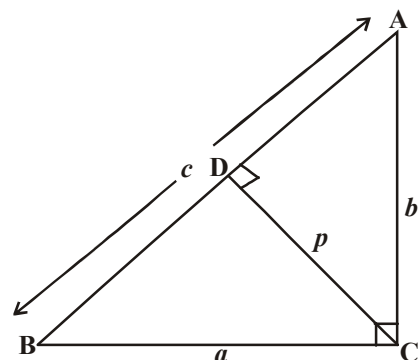
$$= \frac{1}{2} cp.$$

$$\text{also area of } \triangle ABC = \frac{1}{2} \times BC \times AC$$

$$= \frac{1}{2} ab$$

$$\frac{1}{2} cp = \frac{1}{2} ab$$

$$cp = ab \quad \dots(1)$$



(ii) Since $\triangle ABC$ is a right triangle right angled at C.

$$AB^2 = BC^2 + AC^2$$

$$c^2 = a^2 + b^2$$

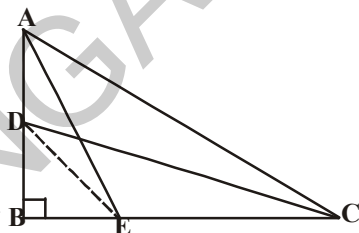
$$\left(\frac{ab}{p}\right)^2 = a^2 + b^2$$

$$\frac{1}{p^2} = \frac{a^2 + b^2}{a^2 b^2} = \frac{1}{a^2} + \frac{1}{b^2}.$$

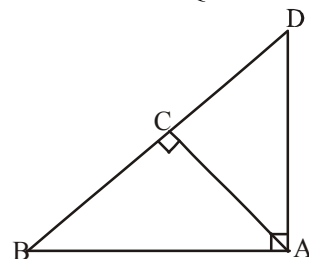


Exercise - 8.4

1. Prove that the sum of the squares of the sides of a rhombus is equal to the sum of the squares of its diagonals.
2. ABC is a right triangle right angled at B. Let D and E be any points on AB and BC respectively.
Prove that $AE^2 + CD^2 = AC^2 + DE^2$.
3. Prove that three times the square of any side of an equilateral triangle is equal to four times the square of the altitude.



4. PQR is a triangle right angled at P and M is a point on QR such that $PM \perp QR$.
Show that $PM^2 = QM \cdot MR$.
5. ABD is a triangle right angled at A and $AC \perp BD$
Show that (i) $AB^2 = BC \cdot BD$.
(ii) $AC^2 = BC \cdot DC$
(iii) $AD^2 = BD \cdot CD$.

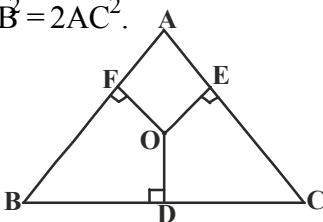


6. ABC is an isosceles triangle right angled at C. Prove that $AB^2 = 2AC^2$.
7. 'O' is any point in the interior of a triangle ABC.

If $OD \perp BC$, $OE \perp AC$ and $OF \perp AB$, show that

$$(i) \quad OA^2 + OB^2 + OC^2 - OD^2 - OE^2 - OF^2 = AF^2 + BD^2 + CE^2$$

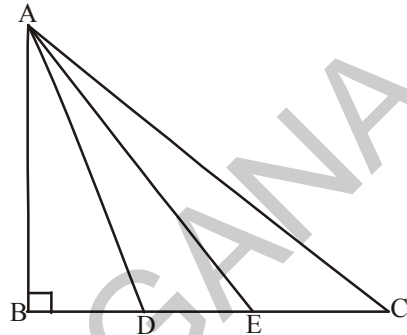
$$(ii) \quad AF^2 + BD^2 + CE^2 = AE^2 + CD^2 + BF^2.$$



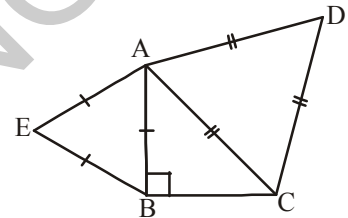
8. A 24m long wire is attached to a vertical pole of height 18m. And it has a stake attached to the other end. How far from the base of the pole should the stake be driven so that the wire will be taut?



9. Two poles of heights 6m and 11m stand on a plane ground. If the distance between the feet of the poles is 12m then find the distance between their tops.
10. In an equilateral triangle ABC, D is a point on side BC such that $BD = \frac{1}{3} BC$. Prove that $9AD^2 = 7AB^2$.
11. In the given figure, ABC is a triangle right angled at B. If points D and E trisect side BC it, then prove that $8AE^2 = 3AC^2 + 5AD^2$.



12. ABC is an isosceles triangle right angled at B. Similar triangles ACD and ABE are constructed on sides AC and AB. Find the ratio between the areas of $\triangle ABE$ and $\triangle ACD$.



13. Equilateral triangles are drawn on the three sides of a right angled triangle. Show that the area of the triangle on the hypotenuse is equal to the sum of the areas of triangles on the other two sides.
14. Prove that the area of the equilateral triangle described on the side of a square is half the area of the equilateral triangles described on its diagonal.

8.7 Different forms of theoretical statements

1. Negation of a statement :

We have a statement and if we add “Not” in the statement, we will get a new statement; which is called negation of the statement.

For example take a statement “ $\triangle ABC$ is an equilateral”. If we denote it by “ p ”, we can write like this.

p : Triangle ABC is equilateral and its negation will be “Triangle ABC is not equilateral”. Negation of statement p is denoted by $\sim p$; and read as negation of p . the statement $\sim p$ negates the assertion that the statement p makes.

When we write the negation of the statements, we would be careful that there should not be any confusion in understanding the statement.



Observe this example carefully

p : All irrational numbers are real numbers. We can write negation of p ($\sim p$) like this.

$\sim p$: All irrational numbers are not real numbers.

How do we decide this negation is true or false? We use the following criterion “Let p be a statement and $\sim p$ its negation. Then $\sim p$ is false whenever p is true and $\sim p$ is true whenever p is false.

For example s : $2 + 2 = 4$ is True

$\sim s$: $2 + 2 \neq 4$ is False

2. Converse of a statement :

A sentence which is either true or false is called a simple statement. If we combine two simple statements, then we will get a compound statement. Connecting two simple statements with the use of the words “If and then” will give a compound statement which is called implication (or) conditional.

Combining two simple statements p & q using if and then, we get p implies q which can be denoted by $p \Rightarrow q$.

In this $p \Rightarrow q$, suppose we interchange p and q we get $q \Rightarrow p$. This is called its converse.

Example : $p \Rightarrow q$: In ΔABC , if $AB = AC$ then $\angle C = \angle B$

Converse $q \Rightarrow p$: In ΔABC , if $\angle C = \angle B$ then $AB = AC$

3. Proof by contradiction :

In this proof by contradiction, we assume that the negation of the statement as true; which we have to prove. In the process of proving, we get contradiction somewhere. Then, we realize that this contradiction occurs because of our wrong assumption that the negation is true. Therefore, we conclude that the original statement is true.

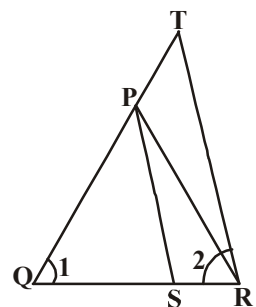


Optional Exercise

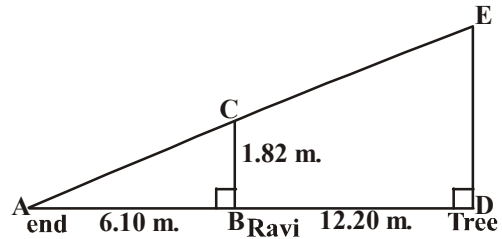
[For extensive learning]

1. In the given figure,

$\frac{QT}{PR} = \frac{QR}{QS}$ and $\angle 1 = \angle 2$, prove that $\Delta PQS \sim \Delta TQR$.



2. Ravi is 1.82m tall. He wants to find the height of a tree in his backyard. From the tree's base he walked 12.20m. along the tree's shadow to a position where the end of his shadow exactly overlaps the end of the tree's shadow. He is now 6.10m from the end of the shadow. How tall is the tree ?

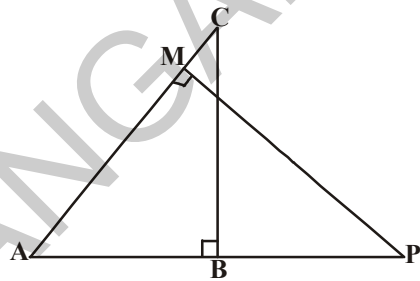


3. The diagonal AC of a parallelogram ABCD intersects DP at the point Q, where 'P' is any point on side AB. Prove that $CQ \times PQ = QA \times QD$.
4. $\triangle ABC$ and $\triangle AMP$ are two right triangles right angled at B and M respectively.

Prove that (i) $\triangle ABC \sim \triangle AMP$ and

$$(ii) \frac{CA}{PA} = \frac{BC}{MP}.$$

5. An aeroplane leaves an airport and flies due north at a speed of 1000 kmph. At the same time, another aeroplane leaves the same airport and flies due west at a speed of 1200 kmph. How far apart will the two planes be after $1\frac{1}{2}$ hour?
6. In a right triangle ABC right angled at C, P and Q are points on sides AC and CB respectively which divide these sides in the ratio of 2 : 1.



Prove that (i) $9AQ^2 = 9AC^2 + 4BC^2$

$$(ii) 9BP^2 = 9BC^2 + 4AC^2$$

$$(iii) 9(AQ^2 + BP^2) = 13AB^2$$

Suggested Projects

- Find the height of a tree/ tower/ temple etc. using the properties of similar triangles, use the procedure discussed in 'Introduction of Similar Triangles'



What We Have Discussed

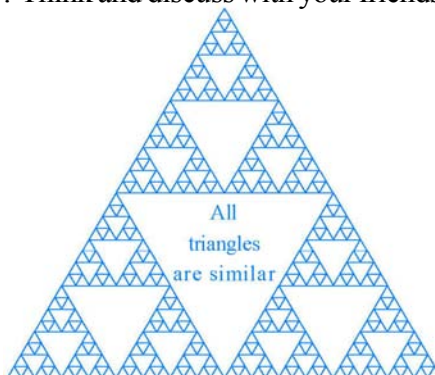
- Two figures having the same shape with all parts in proportion are called similar figures.
- All the congruent figures are similar but the converse is not true.



3. Two polygons of the same number of sides are similar, if
 - (i) their corresponding angles are equal and
 - (ii) their corresponding sides are in the same ratio (i.e. proportion)
4. If a line is drawn parallel to one side of a triangle to intersect the other two sides at distinct points then the other two sides are divided in the same ratio.
5. If a line divides any two sides of a triangle in the same ratio, then the line is parallel to the third side.
6. In two triangles, if corresponding angles are equal, then their corresponding sides are in the same ratio and hence the two triangles are similar (AAA similarity)
7. If two angles of a triangle are equal to the two angles of another triangle, then the two triangles are similar. (AA similarity)
8. In two triangles, if corresponding sides are in the same ratio, then their corresponding angles are equal and hence the triangles are similar. (SSS similar)
9. If one angle of a triangle is equal to one angle of another triangle and the including sides of these angles are in the same ratio, then the triangles are similar. (SAS similarity)
10. The ratio of areas of two similar triangles is equal to the square of the ratio of their corresponding sides.
11. If a perpendicular is drawn from the vertex of the right angle to the hypotenuse in a right angle triangle, then the triangles formed on both sides of the perpendicular are similar to the whole triangle and also to each other.
12. In a right triangle, the square of the hypotenuse is equal to the sum of the squares of the other two sides (Pythagorean Theorem).
13. In a triangle, if square of one side is equal to the sum of the squares of the other two sides, then the angle opposite to the first side is a right angle and the triangle is a right angled triangle.

Puzzle

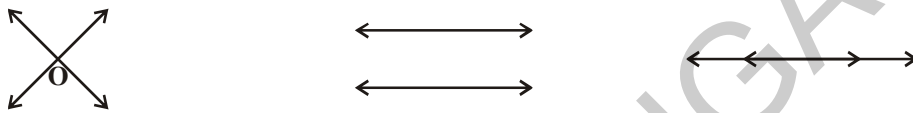
Draw a triangle. Join the mid-point of the sides of the triangle. You get 4 triangles again join the mid-points of these triangles. Repeat this process. All the triangles drawn are similar triangles. Why? Think and discuss with your friends.



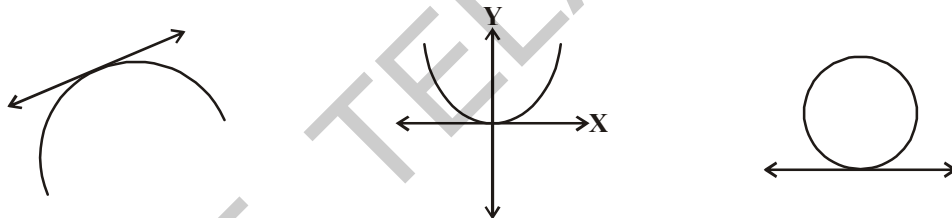


9.1 Introduction

We have seen that two lines in a plane may intersect at a point or may not intersect. In some situations, they may coincide with each other.



Similarly, what are the possible relative positions of a curve and a line given in a plane? A curve may be a parabola as you have seen in polynomials or a simple closed curve like a “circle” which is a collection of all those points on a plane that are at a constant distance from a fixed point.



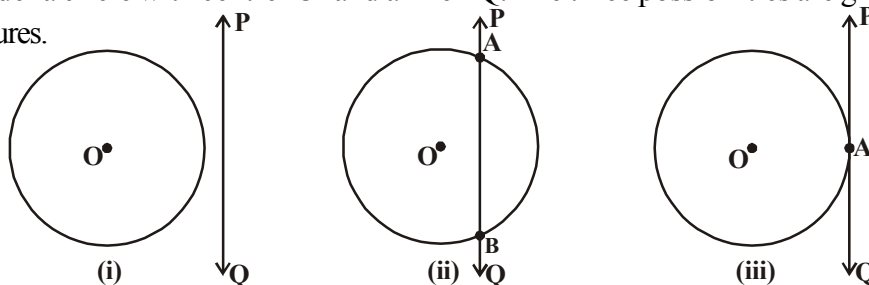
You might have seen circular objects rolling on a plane creating a path. For example; bicycle wheel on a sandy field, wheels of train on the track etc., where a circle as well as a line are involved.

Let us observe the relative positions of a circle and a line are given in a plane.

9.1.1 A Line and A Circle

You are asked to draw a circle and a line on a paper. Abhiram argues that there can only be 3 possible ways of presenting them on a paper.

Consider a circle with centre ‘O’ and a line PQ. The three possibilities are given in the following figures.



In Fig. (i), the line PQ and the circle have no common point. In this case, PQ is a non-intersecting line with respect to the circle.

In Fig. (ii), the line PQ intersects the circle at two points A and B. It forms **chord** \overline{AB} with its end points A and B on the circle. In this case, the line PQ is **secant** of the circle.

In Fig. (iii), there is only one point A, common to the line PQ and the circle. This line is called a **tangent** to the circle.

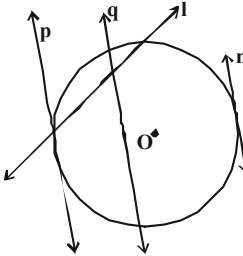
You can see that there cannot be any other position of the line with respect to the circle. We will study the existence of tangents to a circle and also study their properties and constructions.

Do you know?

The word 'tangent' comes from the latin word 'tangere', which means to touch and was introduced by Danish mathematician Thomas Fineke in 1583.

👤 **Do This**

- i. Draw a circle with any radius. Draw four tangents at different points. How many more tangents can you draw to this circle?
- ii. How many tangents can you draw to a circle from a point away from it?
- iii. In the adjacent figure, which lines are tangents to the circle?



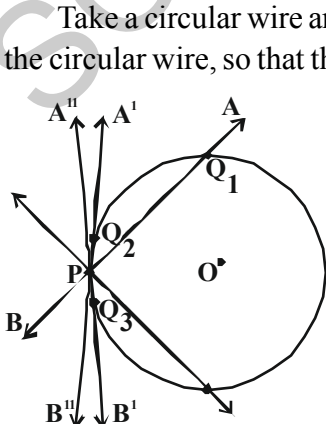
9.2 Tangents of a Circle

We can see that tangent to a circle can be drawn at any point on the circle. How many tangents can be drawn at any point on the circle?

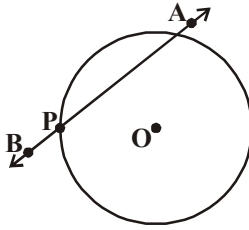
To understand this let us consider the following activity.

📈 **Activity**

Take a circular wire and attach a straight wire AB at a point P of the circular wire, so that the system can rotate about the point P in a plane. The circular wire represents a circle and the straight wire AB represents a line intersects the circle at point P.



Place the system on a table and gently rotate the wire AB about the point P to get different positions of the straight wire as shown in the figure. The wire intersects the circular wire at P and at one of the points Q_1 , Q_2 or Q_3 etc. So while it generally intersects circular wire at two points one of which is P in one particular position, it intersects the circle only at




the point P (See position A' B' of AB). This is the position of a tangent at the point P to the circle. You can check that in all other positions of AB, it will intersect the circle at P at another point. Thus A' B' is a tangent to the circle at P.

We see that there is only one tangent to the circle at point P.

Moving wire AB in either direction from this position makes it cut the circular wire in two points. All these are therefore secants. Tangent is a special case of a secant where the two points of intersection of a line with a circle coincide.



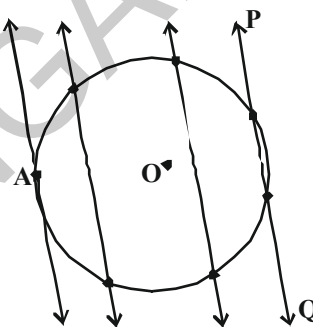
Do This

Draw a circle and a secant PQ to the circle on a paper as shown in the figure. Draw various lines parallel to the secant on both sides of it.

What happens to the length of chord coming closer and closer to the centre of the circle?

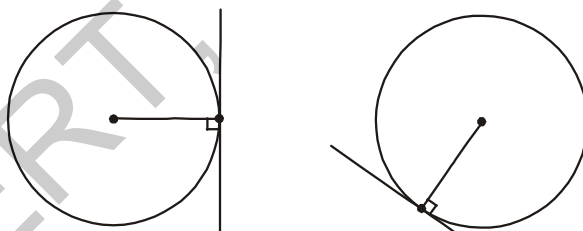
What is the longest chord?

How many tangents can you draw to a circle, which are parallel to each other?



The common point of a tangent and the circle is called the **point of contact** and the tangent is said to touch the circle at the common point.

Observe the tangents to the circle in the figures given below:

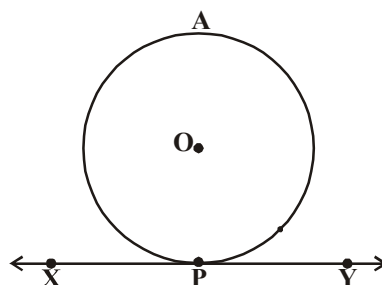


How many tangents can you draw to a circle at a point on it? How many tangents can you draw to the circle in all? See the point of contact. Draw radii from the points of contact. Do you see anything special about the angle between the tangents and the radii at the points of contact. All appear to be perpendicular to the corresponding tangents. We can also prove it. Let us see how.

Theorem-9.1 : The tangent at any point of a circle is perpendicular to the radius through the point of contact.

Given : A circle with centre 'O' and a tangent XY to the circle at a point P and \overline{OP} radius.

To prove : OP is perpendicular to XY. i.e XY is tangent to circle



Proof : Take a point Q on \overline{XY} other than P and join O and Q. The point Q must lie outside the circle (why?) (Note that if Q lies inside the circle, XY becomes a secant and not a tangent to the circle)

Therefore, OQ is longer than the radius OP of the circle [Why?]

i.e., $OQ > OP$.

This must happen for all points on the line XY. It is therefore true that OP is the shortest of all the distances of the point O to the XY.

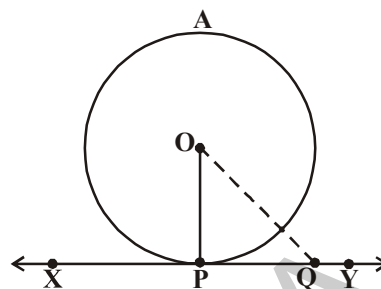
As a perpendicular is the shortest in length among all line segments drawn from a point to the line (Activity 5.3 of 7th class).

Therefore OP is perpendicular to XY.

i.e., $\overline{OP} \perp \overline{XY}$

Hence, proved.

Note : The line containing the radius through the point of contact is also called the **normal** to the circle at the point'.



Try This

How can you prove the converse of the above theorem.

“If a line in the plane of a circle is perpendicular to the radius at its endpoint on the circle, then the line is tangent to the circle”.

We can find some more results using the above theorem

- (i) Since there can be only one perpendicular OP at the point P, it follows that one and only one tangent can be drawn to a circle at a given point on the circle.
- (ii) Since there can be only one perpendicular to XY at the point P, it follows that the perpendicular to a tangent to a circle at its point of contact passes through the centre.

Think about these. Discuss these among your friends and with your teachers.

9.2.1 Construction of Tangent to a Circle

How can we construct a line that would be tangent to a circle at a given point on it? We use what we just found i.e. the tangent has to be perpendicular to the radius at the point of contact. To draw a tangent through the point of contact we need to draw a line perpendicular to the radius at that point. To draw this radius we need to know the center of the circle.

Let us see the steps for this construction.

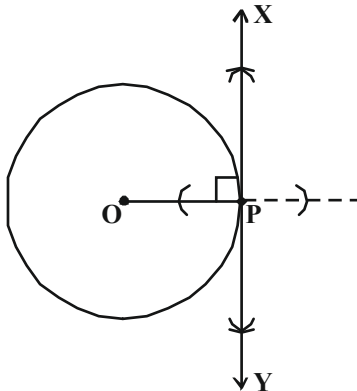


Construction : Construct a tangent to a circle at a given point on it, when the centre of the circle is known.

We have a circle with centre 'O' and a point P anywhere on its circumference. Then, we have to construct a tangent through P.

Let us observe steps of construction to draw a tangent.

Steps of Construction :

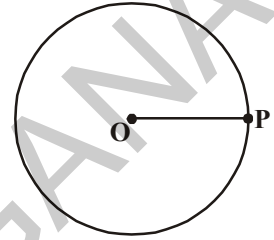


1. Draw a circle with centre 'O' and mark a point 'P' anywhere on it. Join O and P.

2. Draw a perpendicular line through the point P and name it as XY, as shown in the figure.

3. XY is the required tangent to the given circle passing through P.

Can you draw one more tangent through P ? give reason.



💡 **Try This**

How can you draw the tangent to a circle at a given point when the centre of the circle is not known?

Hint : Draw equal angles $\angle XPQ$ and $\angle PRQ$. Explain the construction.

9.2.2 Finding Length of the Tangent

Can we find the length of the tangent PA to a circle from a given point?

Example : Find the length of the tangent to a circle with centre 'O' and radius = 6 cm. from a point P such that OP = 10 cm.

Solution : Tangent is perpendicular to the radius at the point of contact (Theorem 9.1)

Here, PA is tangent segment and OA is radius of circle

$$\therefore \overline{OA} \perp \overline{PA} \Rightarrow \angle OAP = 90^\circ$$

Now, in ΔOAP , $OP^2 = OA^2 + PA^2$ (pythagoras theorem)

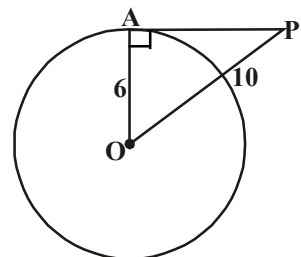
$$10^2 = 6^2 + PA^2$$

$$100 = 36 + PA^2$$

$$PA^2 = 100 - 36$$

$$= 64$$

$$\therefore PA = \sqrt{64} = 8 \text{ cm.}$$





Exercise - 9.1

- Fill in the blanks
 - A tangent to a circle touches it in point (s).
 - A line intersecting a circle in two points is called a
 - Maximum number of tangents can be drawn to a circle parallel to the given tangent is
 - The common point of a tangent to a circle and the circle is called
 - We can draw tangents to a given circle.
 - A circle can have parallel tangents at the most.
- A tangent PQ at a point P of a circle of radius 5 cm meets a line through the centre O at a point Q so that $OQ = 13$ cm. Find length of PQ.
- Draw a circle and two lines parallel to a given line drawn outside the circle such that one is a tangent and the other, a secant to the circle.
- Calculate the length of tangent from a point 15 cm away from the centre of a circle of radius 9 cm.
- Prove that the tangents to a circle at the end points of a diameter are parallel.

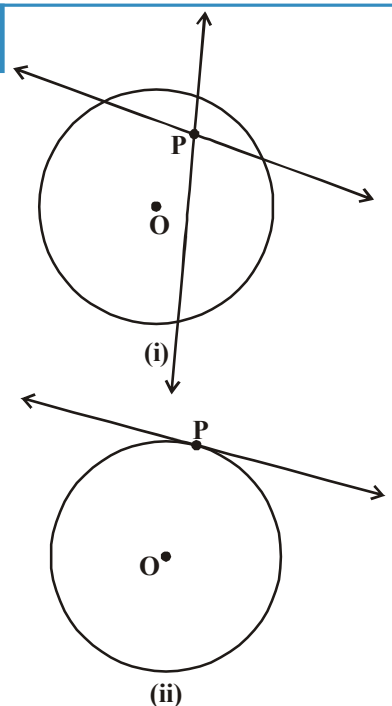
9.3 Number of tangents to a circle from any point

To get an idea of the number of tangents from a point in a plane, let us perform the following activity.

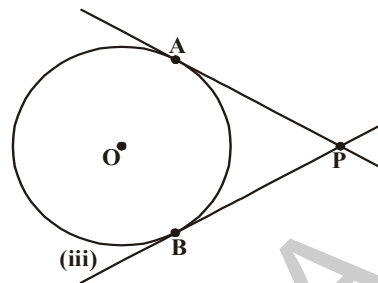


Activity

- Draw a circle on a paper. Take a point P inside it. Can you draw a tangent to the circle through this point? You will find that all the lines through this point intersect the circle in two points. What are these? These are all secants of a circle. So, it is not possible to draw any tangent to a circle through a point inside it. (See the adjacent figure)
- Next, take a point P on the circle and draw tangents through this point. You have observed that there is only one tangent to the circle at a such a point. (See the adjacent figure)



(iii) Now, take a point P outside the circle and try to draw tangents to the circle from this point. What do you observe? You will find that you can draw exactly two tangents to the circle through this point (See the adjacent figure)



Now, we can summarise these facts as follows :

Case (i): *There is no tangent to a circle passing through a point inside the circle.*

Case(ii): *There is one and only one tangent to a circle at a point on the circle.*

Case(iii): *There are exactly two tangents to a circle through a point outside the circle. In this case, A and B are the points of contacts of the tangents PA and PB respectively.*

The length of the segment from the external point P and the point of contact with the circle is called the length of the tangent from the point P to the circle.

Note that in the above figure (iii), PA and PB are the length of the tangents from P to the circle. What is the relation between lengths PA and PB?

Theorem-9.2 : The lengths of tangents drawn from an external point to a circle are equal.

Given : A circle with centre O, P is a point outside the circle and PA and PB are two tangents to the circle from P. (See figure)

To prove : PA = PB

Proof : Join OA, OB and OP.

$$\angle OAP = \angle PBO = 90^\circ$$

Now, in the two triangles $\triangle OAP$ and $\triangle OBP$,

[(Angle between radii and tangents is 90° according to theorem 9.1)]

$$OA = OB \quad (\text{radii of same circle})$$

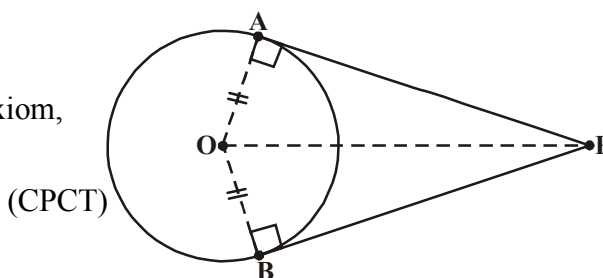
$$OP = OP \quad (\text{Common})$$

Therefore, by R.H.S. Congruency axiom,

$$\triangle OAP \cong \triangle OBP$$

$$\text{This gives } PA = PB$$

Hence proved.



Try This

Use Pythagoras theorem to write a proof of the above theorem.



9.3.1. Construction of Tangents to a Circle from an External point

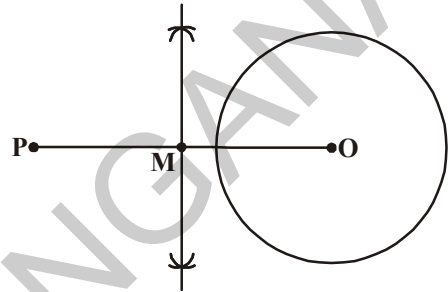
You have seen that if a point lies outside the circle, there will be exactly two tangents to the circle from this point. We shall now see how to draw these tangents.

Construction : To construct the tangents to a circle from a point outside it.

Given : We are given a circle with centre 'O' and a point P outside it. We have to construct two tangents from P to the circle.

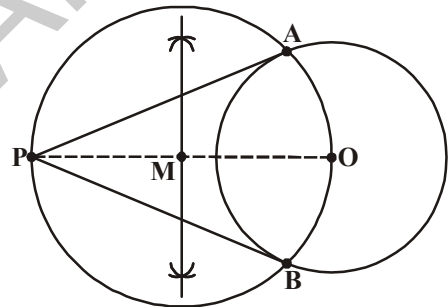
Steps of construction :

Step(i) : Join PO and draw a perpendicular bisector of it. Let M be the midpoint of PO.



Step (ii) : Taking M as centre and PM or MO as radius, draw a circle. Let it intersect the given circle at the points A and B.

Step (iii) : Join PA and PB. Then PA and PB are the required two tangents.



Proof : Now, Let us see how this construction is justified.

Join OA.

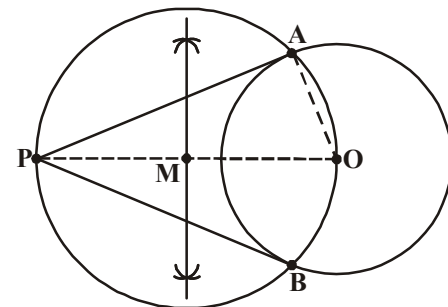
Then $\angle PAO$ is an angle in the semicircle and, therefore, $\angle PAO = 90^\circ$.

Can we say that $PA \perp OA$?

Since, OA is a radius of the given circle, PA has to be a tangent to the circle (By converse theorem of 9.1)

Similarly, PB is also a tangent to the circle.

Hence proved.



Some interesting statements about tangents and secants and their proof.

Statement-1 : The centre of a circle lies on the bisector of the angle between two tangents drawn from a point outside it. Can you think how we can prove it?

Proof : Let PQ and PR be two tangents drawn from a point P outside of the circle with centre O. Join OQ and OR, triangles OQP and ORP are congruent because,



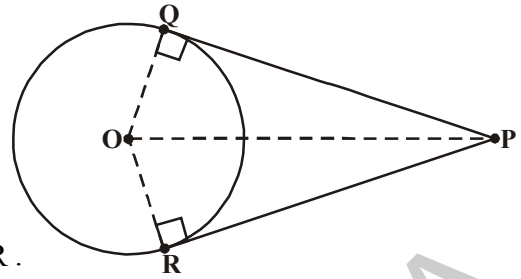
$$\angle OQP = \angle PRO = 90^\circ \text{ (Theorem 9.1)}$$

$$OQ = OR \text{ (Radii)}$$

OP is common.

This means $\angle QPO = \angle OPR$ (CPCT)

Therefore, OP is the bisector angle of $\angle QPR$.



Hence, the centre lies on the bisector of the angle between the two tangents.

Statement-2 : In two concentric circles, the chord of the bigger circle, that touches the smaller circle is bisected at the point of contact with the smaller circle.

Proof : Consider two concentric circles C_1 and C_2 with centre O and a chord AB of the larger circle C_1 , touching the smaller circle C_2 at the point P (See the figure). We need to prove that $AP = PB$.

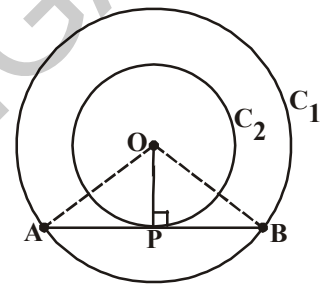
Join OP.

Then, AB is a tangent to the circle C_2 at P and OP is its radius.

Therefore, by Theorem 9.1,

$$OP \perp AB$$

Now, $\triangle OAP$ and $\triangle OBP$ are congruent. (Why?) This means $AP = PB$. Therefore, OP is the bisector of the chord AB, as the perpendicular from the centre bisects the chord.



Statement-3 : If two tangents AP and AQ are drawn to a circle with centre O from an external point A, then $\angle QAP = 2\angle QPO = 2\angle OQP$.

Proof : We are given a circle with centre O, an external point A and two tangents AP and AQ to the circle, where P, Q are the points of contact (See figure).

We need to prove that

$$\angle QAP = 2\angle QPO$$

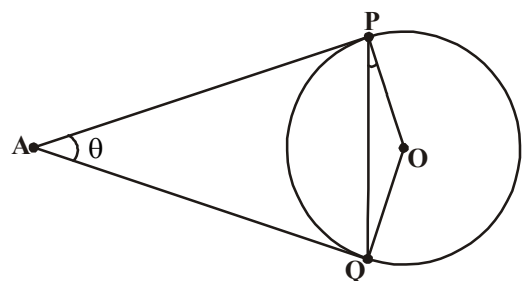
$$\text{Let } \angle QAP = \theta$$

Now, by Theorem 9.2,

$$AP = AQ.$$

So $\triangle APQ$ is an isosceles triangle

$$\text{Therefore, } \angle APQ + \angle PQA + \angle QAP = 180^\circ \text{ (Sum of three angles)}$$



$$\begin{aligned}\Rightarrow \angle APQ = \angle PQA &= \frac{1}{2}(180^\circ - \theta) \\ &= 90^\circ - \frac{1}{2}\theta\end{aligned}$$

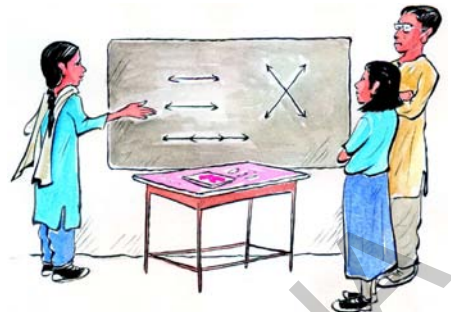
Also, by Theorem 9.1, $\angle OPA = 90^\circ$

So, $\angle OPQ = \angle OPA - \angle APQ$

$$= 90^\circ - \left[90^\circ - \frac{1}{2}\theta\right] = \frac{1}{2}\theta = \frac{1}{2}\angle PAQ$$

This gives $\angle OPQ = \frac{1}{2}\angle PAQ$.

$\therefore \angle PAQ = 2\angle OPQ$. Similarly $\angle PAQ = 2\angle OQP$



Statement-4 : If a quadrilateral ABCD is drawn to circumscribe a circle, then $AB + CD = BC + DA$.

Proof : Since, the circle touches the sides AB, BC, CD and DA of quadrilateral ABCD at the points P, Q, R and S respectively as shown, in the figure \overline{AB} , \overline{BC} , \overline{CD} and \overline{DA} are tangents to the circle.

Since, the two tangents to a circle drawn from a point outside it are equal, by theorem 9.2.

$$AP = AS$$

$$BP = BQ$$

$$DR = DS$$

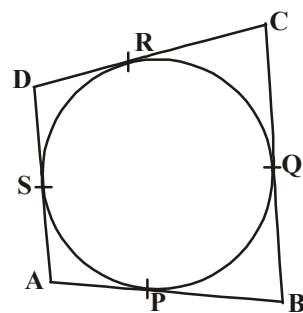
and $CR = CQ$

On adding, we get

$$AP + BP + DR + CR = AS + BQ + DS + CQ$$

$$\text{or } (AP + PB) + (CR + DR) = (BQ + QC) + (DS + SA)$$

$$\text{or } AB + CD = BC + DA.$$



Example-1. Draw a pair of tangents to a circle of radius 5cm which are inclined to each other at an angle 60° .

Solution : To draw the circle and the two tangents we need to see how we proceed. We only have the radius of the circle and the angle between the tangents. We do not know the distance of the point from where the tangents are drawn to the circle and we do not know the length of the tangents either. We know only the angle between the tangents. Using this, we need to find out the distance of the point outside the circle from which we have to draw the tangents.

To begin, let us consider a circle with centre 'O' and radius 5cm. Let PA and PB are two tangents drawn from a point 'P' outside the circle and the angle between them is 60° . In this $\angle APB = 60^\circ$. Join OP.

As we know,

OP is the bisector of $\angle APB$,

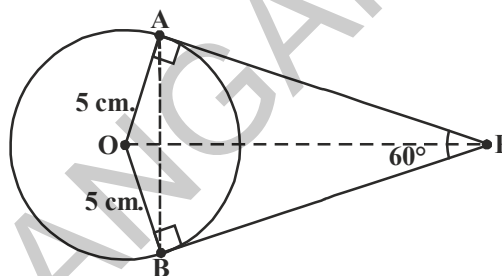
$$\angle OPA = \angle OPB = \frac{60^\circ}{2} = 30^\circ (\because \triangle OAP \cong \triangle OBP)$$

Now In $\triangle OAP$,

$$\sin 30^\circ = \frac{\text{Opp. side}}{\text{Hyp}} = \frac{OA}{OP}$$

$$\frac{1}{2} = \frac{5}{OP} \text{ (From trigonometric ratios)}$$

$$OP = 10 \text{ cm.}$$

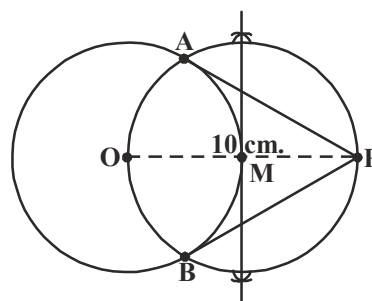


Now we can draw a circle of radius 5 cm with centre 'O'. We then mark a point at a distance of 10 cm from the centre of the circle. Join OP and complete the construction as given in construction 9.2.

Hence PA and PB are the required pair of tangents to the given circle.

In $\triangle OAP$; $\angle A = 90^\circ$, $\angle P = 30^\circ$, $\angle O = 60^\circ$ and $OA = 5 \text{ cm}$. Construct $\triangle AOP$ to get P.

You can also try this construction without using trigonometric ratio.



Try This

Let us try the above construction in another method.

Draw a pair of radii OA and OB in a circle such that $\angle BOA = 120^\circ$. Draw the bisector of $\angle BOA$ and draw lines perpendiculars to OA and OB at A and B. These lines meet on the bisector of $\angle BOA$ at a point which is the external point and the perpendicular lines are the required tangents. Construct and Justify.



Exercise - 9.2

- Choose the correct answer and give justification for each.
 - The angle between a tangent to a circle and the radius drawn at the point of contact is
 - 60°
 - 30°
 - 45°
 - 90°



(ii) From a point Q, the length of the tangent to a circle is 24 cm. and the distance of Q from the centre is 25 cm. The radius of the circle is

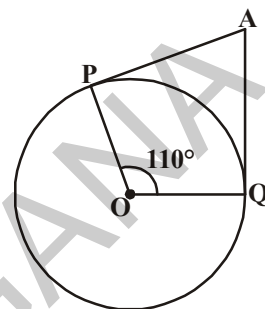
- (a) 7cm (b) 12 cm (c) 15cm (d) 24.5cm

(iii) In the adjacent figure AP and AQ are the two tangents a circle with centre O so that $\angle QOP = 110^\circ$, then $\angle PAQ =$

- (a) 60° (b) 70° (c) 80° (d) 90°

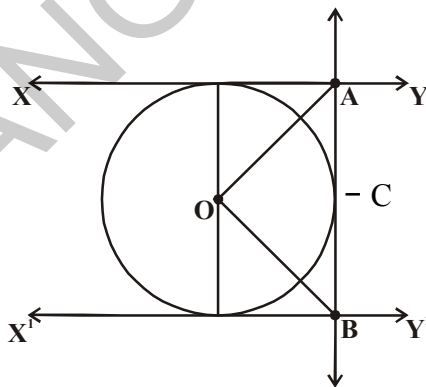
(iv) In the adjacent figure tangents PA and PB from a point P to a circle with centre O are inclined to each other at angle of 80° , then $\angle POA =$

- (a) 50° (b) 60° (c) 70° (d) 80°



(v) In the figure, XY and X^1Y^1 are two parallel tangents to a circle with centre O and another tangent AB with point of contact C intersecting XY at A and X^1Y^1 at B then $\angle BOA =$

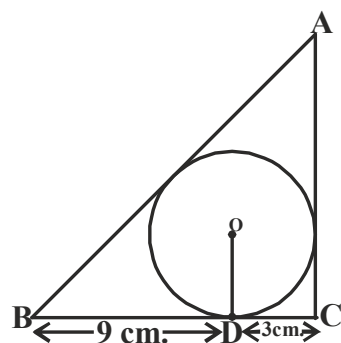
- (a) 80° (b) 100° (c) 90° (d) 60°



2. Two concentric circles of radii 5 cm and 3cm are drawn. Find the length of the chord of the larger circle which touches the smaller circle.

3. Prove that the parallelogram circumscribing a circle is a rhombus.

4. A triangle ABC is drawn to circumscribe a circle of radius 3 cm. such that the segments BD and DC into which BC is divided by the point of contact D are of length 9 cm. and 3 cm. respectively (See adjacent figure). Find the sides AB and AC.



5. Draw a circle of radius 6cm. From a point 10 cm away from its centre, construct the pair of tangents to the circle and measure their lengths. Verify by using Pythagoras Theorem.

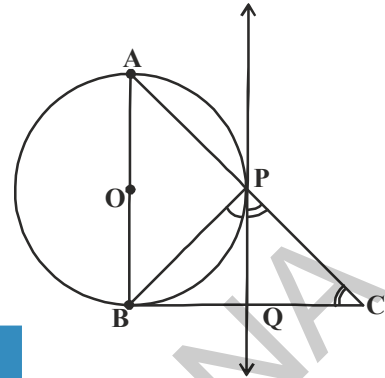
6. Construct a tangent to a circle of radius 4cm from a point on the concentric circle of radius 6cm and measure its length. Also verify the measurement by actual calculation.

7. Draw a circle with the help of a bangle. Take a point outside the circle. Construct the pair of tangents from this point to the circle and measure them. What did you observe.



8. In a right triangle ABC, a circle with a side AB as diameter is drawn to intersect the hypotenuse AC in P. Prove that the tangent to the circle at P bisects the side BC.
9. Draw a tangent to a given circle with center O from a point 'R' outside the circle. How many tangents can be drawn to the circle from that point?

Hint : The distance of the point to the two points of contact is the same.

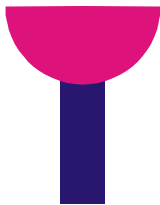


9.4 Segment of a circle formed by a secant

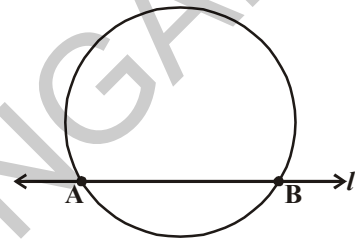
We have seen a line and a circle. When a line meets a circle in only one point, it is a tangent. A secant is a line which intersects the circle at two distinct points and the line segment between the points is a chord.

Here, 'l' is the secant and AB is the chord.

Shankar is making a picture by sticking pink and blue paper. He makes many pictures. One picture he makes is of a washbasin. How much paper does he need to make this picture?

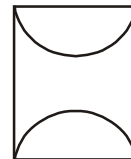
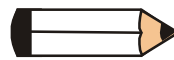
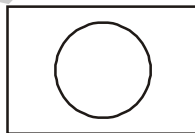


This picture can be seen in two parts. There is a rectangle below, but what is the remaining part? It is the segment of a circle. We know how to find the area of rectangle. How do we find the area of the segment? In the following discussion, we will try to find this area.



Do This

Shankar made the following pictures also.



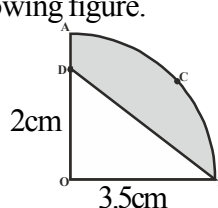
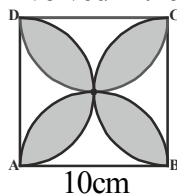
To find area of a figure, identify what are the shapes involved in it?

Make some more pictures and think of the shapes they can be divided into different parts.

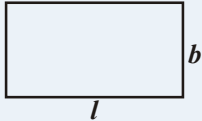
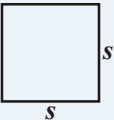
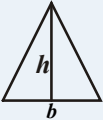
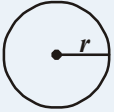


Try This

Name the shapes involved in the following figure.

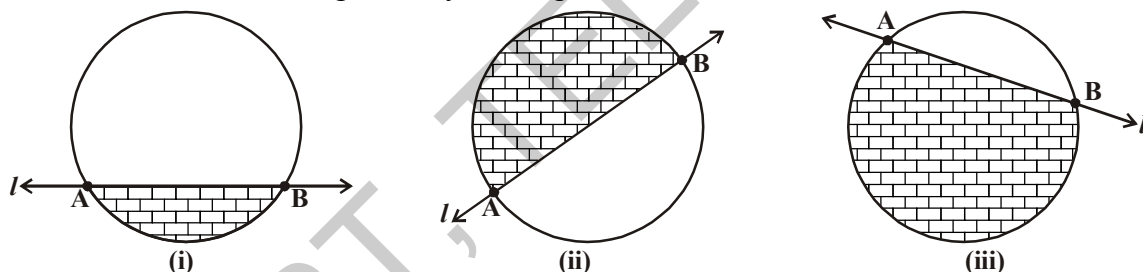



Lets us recall the formulae of the area of the following geometrical figures as given in the table.

S.No.	Figure	Dimensions	Area
1.		length = l breadth = b	$A = lb$
2.		Side = s	$A = s^2$
3.		height = h base = b	$A = \frac{1}{2}bh$
4.		radius = r	$A = \pi r^2$

9.4.1. Finding the Area of Segment of a Circle

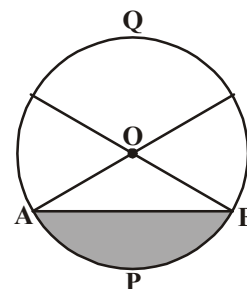
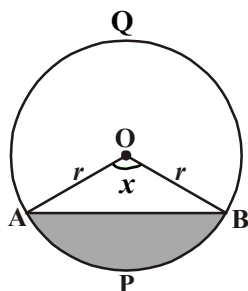
Swetha made the segments by drawing secants to the circle.



As you know, a segment is a region bounded by an arc and a chord. The area that is shaded () in fig. (i) is a minor segment, a semicircle in fig. (ii) and a major segment in fig. (iii).

How do we find the area of a segment? Do the following activity.

Take a small circular paper and fold it along a chord and shade the smaller part as shown in the figure. What do we call this smaller part? It is a minor segment (APB). What do we call the unshaded portion of the circle? Obviously it is a major segment (AQB).



You have already come across the sectors and segments in earlier classes. The portion of some unshaded part and shaded part (minor segment) is a sector which is the combination of a triangle and a segment.



Let OAPB be a sector of a circle with centre O and radius 'r' as shown in the figure. Let the measure of $\angle AOB$ be ' x° '.

You know that the area of a circle is πr^2 and the angle measured at the centre is 360° .

So, when the degree measure of the angle at the centre is 1° , then area of the corresponding sector is $\frac{1^\circ}{360^\circ} \times \pi r^2$.

Therefore, when the degree measure of the angle at the centre is x° , the area of the sector is $\frac{x^\circ}{360^\circ} \times \pi r^2$.

Now let us take the case of the area of the segment APB of a circle with centre 'O' and radius 'r'. You can see that

$$\text{Area of the segment APB} = \text{Area of the sector OAPB} - \text{Area of } \triangle OAB$$

$$= \frac{x^\circ}{360^\circ} \times \pi r^2 - \text{area of } \triangle OAB$$



Try This

How can you find the area of a major segment using area of the corresponding minor segment?



Do This

- Find the area of sector, whose radius is 7 cm. with the given angle:
 - 60°
 - 30°
 - 72°
 - 90°
 - 120°
- The length of the minute hand of a clock is 14 cm. Find the area swept by the minute hand in 10 minutes.

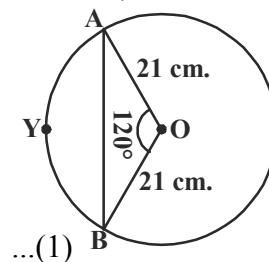
Now, we will see an example to find area of segment of a circle.

Example-1. Find the area of the segment AYB shown in the adjacent figure. It is given that the radius of the circle is 21 cm and $\angle AOB = 120^\circ$ (Use $\pi = \frac{22}{7}$ and $\sqrt{3} = 1.732$)

Solution : Area of the segment AYB

$$= \text{Area of sector OAYB} - \text{Area of } \triangle OAB$$

$$\begin{aligned} \text{Now, area of the sector OAYB} &= \frac{120^\circ}{360^\circ} \times \frac{22}{7} \times 21 \times 21 \text{ cm}^2 \\ &= 462 \text{ cm}^2 \end{aligned}$$



For finding the area of $\triangle OAB$, draw $OM \perp AB$ as shown in the figure:-

Note $OA = OB$. Therefore, by RHS congruence, $\triangle AMO \cong \triangle BMO$.



So, M is the midpoint of AB and

$$\angle AOM = \angle BOM = \frac{1}{2} \times 120^\circ = 60^\circ$$

Let, OM = x cm

So, from $\triangle OMA$, $\frac{OM}{OA} = \cos 60^\circ$.

or, $\frac{x}{21} = \frac{1}{2}$ $\left(\because \cos 60^\circ = \frac{1}{2} \right)$

or, $x = \frac{21}{2}$

So, OM = $\frac{21}{2}$ cm

Also, $\frac{AM}{OA} = \sin 60^\circ$

$$\frac{AM}{21} = \frac{\sqrt{3}}{2} \quad \left(\because \sin 60^\circ = \frac{\sqrt{3}}{2} \right)$$

So, AM = $\frac{21\sqrt{3}}{2}$ cm.

Therefore, AB = 2AM = $\frac{2 \times 21\sqrt{3}}{2}$ cm. = $21\sqrt{3}$ cm

So, Area of $\triangle OAB = \frac{1}{2} \times AB \times OM$

$$= \frac{1}{2} \times 21\sqrt{3} \times \frac{21}{2} \text{ cm}^2.$$

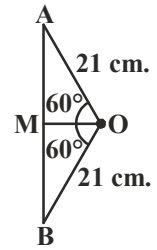
$$= \frac{441}{4} \sqrt{3} \text{ cm}^2. \quad \dots(2)$$

From (1), (2)

Therefore, area of the segment AYB = $\left(462 - \frac{441}{4} \sqrt{3} \right) \text{ cm}^2$.

$$= \frac{21}{4} (88 - 21\sqrt{3}) \text{ cm}^2$$

$$= 271.047 \text{ cm}^2$$



Example-2. Find the area of the segments shaded in figure, if $PQ = 24$ cm., $PR = 7$ cm. and QR is the diameter of the circle with centre O (Take $\pi = \frac{22}{7}$)

Solution : Area of the segments shaded = Area of sector $OQPR$ - Area of triangle PQR .

Since QR is diameter, $\angle QPR = 90^\circ$ (Angle in a semicircle)

So, using Pythagoras Theorem

$$\begin{aligned} \text{In } \triangle QPR, \quad QR^2 &= PQ^2 + PR^2 \\ &= 24^2 + 7^2 \\ &= 576 + 49 \\ &= 625 \\ QR &= \sqrt{625} = 25 \text{ cm.} \end{aligned}$$

$$\text{Then, radius of the circle} = \frac{1}{2} QR$$

$$= \frac{1}{2} (25) = \frac{25}{2} \text{ cm.}$$

$$\text{Now, area of semicircle } OQPR = \frac{1}{2} \pi r^2$$

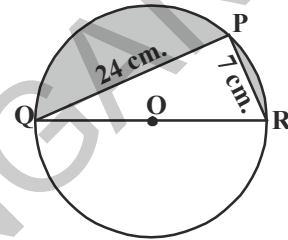
$$\begin{aligned} &= \frac{1}{2} \times \frac{22}{7} \times \frac{25}{2} \times \frac{25}{2} \\ &= 245.53 \text{ cm}^2 \quad \dots (1) \end{aligned}$$

$$\text{Area of right angled triangle } QPR = \frac{1}{2} \times PR \times PQ$$

$$\begin{aligned} &= \frac{1}{2} \times 7 \times 24 \\ &= 84 \text{ cm}^2 \quad \dots (2) \end{aligned}$$

From (1) and (2),

$$\begin{aligned} \text{Area of the shaded segments} &= 245.53 - 84 \\ &= 161.53 \text{ cm}^2 \end{aligned}$$



Example-3. A round table top has six equal designs as shown in the figure. If the radius of the table top is 14 cm., find the cost of making the designs with paint at the rate of ₹5 per cm^2 . (use $\sqrt{3} = 1.732$)



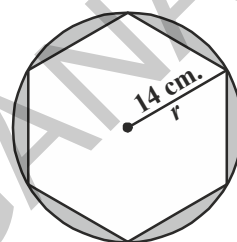
Solution : We know that the radius of circumscribing circle of a regular hexagon is equal to the length of its side.

\therefore Each side of regular hexagon = 14 cm.

Therefore, Area of six design segments = Area of circle - Area of the regular hexagon.

$$\begin{aligned} \text{Now, Area of circle} &= \pi r^2 \\ &= \frac{22}{7} \times 14 \times 14 = 616 \text{ cm}^2 \quad \dots (1) \end{aligned}$$

$$\begin{aligned} \text{Area of regular hexagon} &= 6 \times \frac{\sqrt{3}}{4} a^2 \\ &= 6 \times \frac{\sqrt{3}}{4} \times 14 \times 14 \\ &= 509.2 \text{ cm}^2 \quad \dots (2) \end{aligned}$$



From (1), (2)

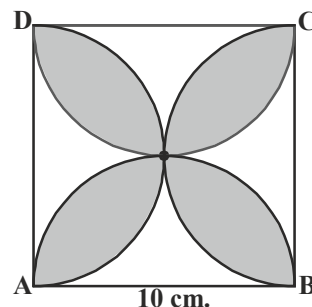
$$\begin{aligned} \text{Hence, area of six designs} &= 616 - 509.21 \\ &= 106.79 \text{ cm}^2. \end{aligned}$$

$$\begin{aligned} \text{Therefore, cost of painting the design at the rate of ₹5 per cm}^2 & \\ &= ₹106.79 \times 5 \\ &= ₹533.95 \end{aligned}$$

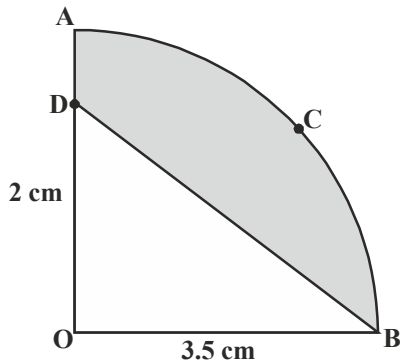
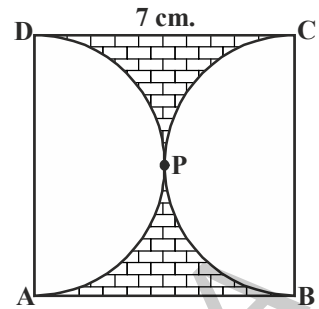


Exercise - 9.3

- In a circle of radius 10 cm, a chord subtends a right angle at the centre. Find the area of the corresponding: (use $\pi = 3.14$)
 - Minor segment
 - Major segment
- In a circle of radius 12 cm, a chord subtends an angle of 120° at the centre. Find the area of the corresponding minor segment of the circle (use $\pi = 3.14$ and $\sqrt{3} = 1.732$)
- A car has two wipers which do not overlap. Each wiper has a blade of length 25 cm sweeping through an angle of 115° . Find the total area cleaned at each sweep of the blades. (use $\pi = \frac{22}{7}$)
- Find the area of the shaded region in the adjacent figure, where ABCD is a square of side 10 cm and semicircles are drawn with each side of the square as diameter (use $\pi = 3.14$)

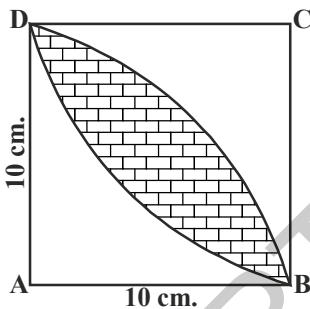
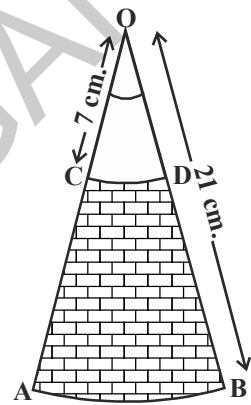


5. Find the area of the shaded region in figure, if ABCD is a square of side 7 cm. and APD and BPC are semicircles. (use $\pi = \frac{22}{7}$)



6. In the adjacent figure, OACB is a quadrant of a circle with centre O and radius 3.5cm. If OD=2cm, find the area of the shaded region. (use $\pi = \frac{22}{7}$)

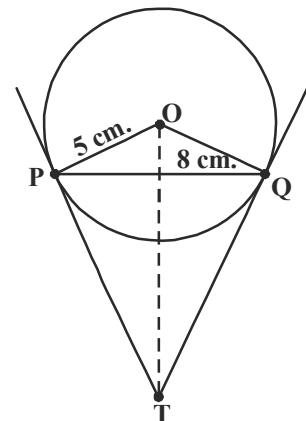
7. AB and CD are respectively arcs of two concentric circles of radii 21 cm and 7 cm with centre O (See figure). If $\angle AOB = 30^\circ$, find the area of the shaded region. (use $\pi = \frac{22}{7}$)



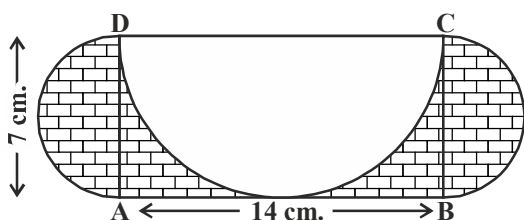
8. Calculate the area of the designed region in figure, common between the two quadrants of the circles of radius 10 cm each. (use $\pi = 3.14$)

Optional Exercise
[For extensive Learning]

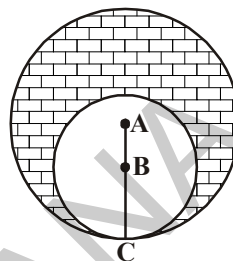
1. Prove that the angle between the two tangents drawn from an external point to a circle is supplementary to the angle subtended by the line segments joining the points of contact to the centre.
2. PQ is a chord of length 8cm of a circle of radius 5cm. The tangents at P and Q intersect at a point T (See figure). Find the length of TP.
3. Prove that opposite sides of a quadrilateral circumscribing a circle subtend supplementary angles at the centre of the circle.
4. Draw a line segment AB of length 8cm. Taking A as centre, draw a circle of radius 4cm and taking B as centre, draw another circle of radius 3cm. Construct tangents to each circle from the centre of the other circle.



- Let $\triangle ABC$ be a right triangle in which $AB = 6$ cm, $BC = 8$ cm and $\angle B = 90^\circ$. BD is the perpendicular from B on AC . The circle through B, C, D is drawn. Construct the tangents from A to this circle.
- Find the area of the shaded region in the figure, in which two circles with centres A and B touch each other at the point C , where $AC = 8$ cm and $AB = 3$ cm.



- $ABCD$ is a rectangle with $AB = 14$ cm and $BC = 7$ cm. Taking DC , BC and AD as diameters, three semicircles are drawn as shown in the figure. Find the area of the shaded region.



What We Have Discussed

In this chapter, we have studied the following points.

- A tangent to a circle is a line which touches the circle at only one point.
- The tangent at any point of a circle is perpendicular to the radius through the point of contact.
- The lengths of the two tangents from an external point to a circle are equal.
- We learnt the following constructions.
 - to construct a tangent to a circle at a given point on the circle when the centre of the circle is known.
 - to construct the pair of tangents from an external point to a circle.
- A secant is a line which intersects the circle at two distinct points and the line segment between the points is a chord.
- We have learnt how to find the area of minor / major segments.

Area of segment of a circle = Area of the corresponding sector \mp Area of the corresponding triangle.





10.1 Introduction

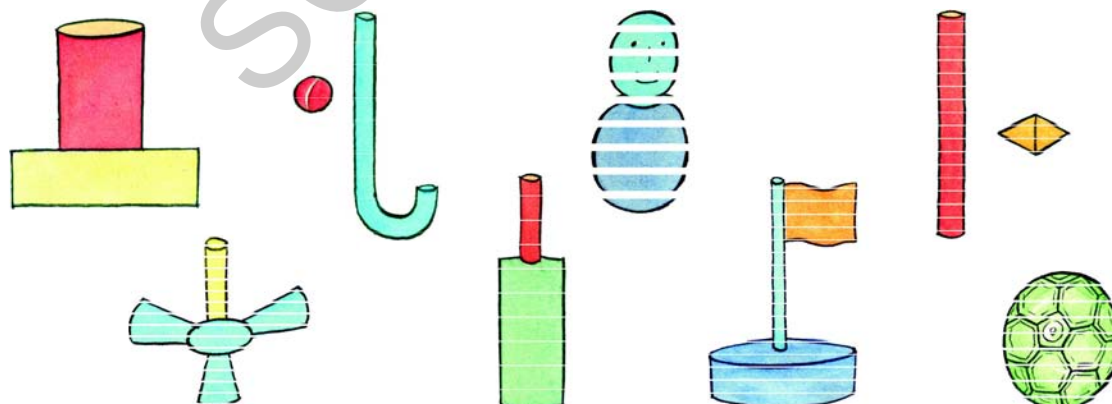
In classes VIII and IX, we have learnt about surface area and volume of regular solid shapes. We use them in real life situations to identify what we need and what is to be measured or estimated.

For example, to find the quantity of paint required to white wash a room, we need the surface area and not the volume. To find the number of bags that are required to store grain, we need the volume and not the area.

Try This

- Consider the following situations. In each situation, find out whether you need to find volume or surface area and why?
 - Quantity of water inside a bottle.
 - Canvas needed for making a tent.
 - Number of bags inside the lorry.
 - Gas filled in a cylinder.
 - Number of match sticks that can be put in the match box.
 - Paper for gift pack
- State 5 more such examples and ask your friends to choose what they need?

We see so many things of different shapes (combination of two or more regular solids) around us. Houses stand on pillars, storage water tanks are cylindrical and are placed on cuboidal foundations, a cricket bat has a cylindrical handle and a flat main body, etc. Think of different objects around you. Some of them are shown below:



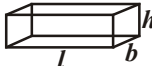



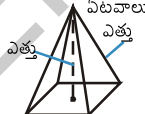
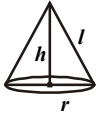
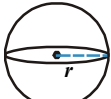



Try This

1. Break the pictures in the previous figure into solids of known shapes.
2. Think of 5 more objects around you that can be seen as a combination of shapes. Name the shapes that combined to make them.

You have learnt how to find the surface area and volume of single regular solids only like a football. We can however see that other objects can be seen as combinations of the solid shapes. So, we now have to learn how to find their surface area and volumes. The table of the solid shapes, their areas and volumes are given below.

Let us recall the surface areas and volumes of different solid shapes.

S. No.	Name of the solid	Figure	Lateral / Curved surface area	Total surface area	Volume (V)	Nomenclature
1.	Cuboid		$2h(l+b)$	$2(lb+bh+hl)$	lbh	l : length b : breadth h : height
2.	Cube		$4a^2$	$6a^2$	a^3	a : side of the cube
3.	Right prism		Perimeter of base \times height	Lateral surface area + 2(area of the end surface)	area of base \times height	-
4.	Regular circular Cylinder		$2\pi r h$	$2\pi r(r+h)$	$\pi r^2 h$	r : radius of the base h : height
5.	Right pyramid		$\frac{1}{2}$ (perimeter of base) \times slant height	Lateral surfaces area + area of the base	$\frac{1}{3}$ area of the base \times height	-
6.	Right circular cone		$\pi r l$	$\pi r(l+r)$	$\frac{1}{3} \pi r^2 h$	r : radius of the base h : height l : slant height
7.	Sphere		$4\pi r^2$	$4\pi r^2$	$\frac{4}{3} \pi r^3$	r : radius
8.	Hemisphere		$2\pi r^2$	$3\pi r^2$	$\frac{2}{3} \pi r^3$	r : radius



Now, let us see some examples to illustrate the method of finding CSA (Curved Surface Area), TSA (Total Surface Area) of the shapes given in the table.

Example-1. The radius of a conical tent is 7m and its height is 10 meters. Calculate the length of canvas used in making the tent, if the width of canvas is 2m. $\left[\text{Use } \pi = \frac{22}{7} \right]$

Solution : The radius of conical tent is (r) = 7m

and height (h) = 10m.

$$\begin{aligned} \therefore \text{ So, the slant height of the cone } (l) &= \sqrt{r^2 + h^2} \quad (\because l^2 = r^2 + h^2) \\ &= \sqrt{49 + 100} \\ &= \sqrt{149} = 12.2 \text{ m.} \end{aligned}$$

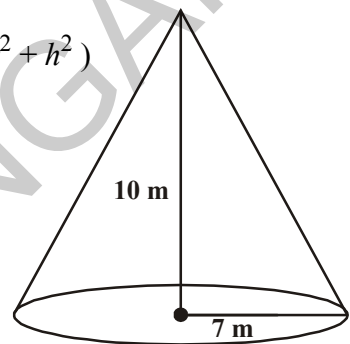
Now, surface area of the tent = $\pi r l$

$$\begin{aligned} &= \frac{22}{7} \times 7 \times 12.2 \text{ m}^2 \\ &= 268.4 \text{ m}^2. \end{aligned}$$

Area of canvas used = 268.4 m^2

It is given that the width of the canvas = 2m

$$\text{Length of canvas used} = \frac{\text{Area}}{\text{width}} = \frac{268.4}{2} = 134.2 \text{ m}$$



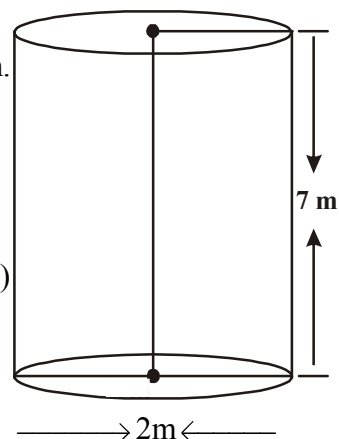
Example-2. An oil drum is in the shape of a cylinder having the following dimensions: diameter is 2 m. and height is 7 m. The painter charges ₹ 3 per m^2 to paint the drum. Find the total charges to be paid to the painter for 10 drums ?

Solution : It is given that diameter of the cylinder (oil drum) = 2 m.

$$\text{Radius of cylinder} = \frac{d}{2} = \frac{2}{2} = 1 \text{ m}$$

Total surface area of a cylindrical drum = $2\pi r(r + h)$

$$\begin{aligned} &= 2 \times \frac{22}{7} \times 1(1 + 7) \\ &= 2 \times \frac{22}{7} \times 8 \end{aligned}$$



$$= \frac{352}{7} \text{ m}^2 = 50.28 \text{ m}^2$$

The total surface area of a drum = 50.28 m^2

Painting charge per 1 m^2 = ₹3.

Cost of painting of 10 drums = $50.28 \times 3 \times 10$
= ₹1508.40

Example-3. A sphere, a cylinder and a cone are of the same radius and same height. Find the ratio of their curved surface areas.

Solution : Let r be the common radius of a sphere, a cone and cylinder.

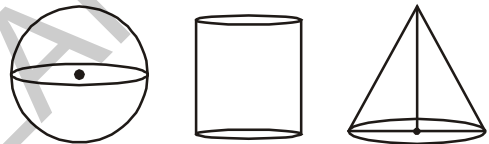
Height of sphere = its diameter = $2r$.

Then, the height of the cone = height of cylinder = height of sphere.

$$= 2r.$$

The slant height of cone $l = \sqrt{r^2 + h^2}$

$$= \sqrt{r^2 + (2r)^2} = \sqrt{5}r$$



$$S_1 = \text{Curved surface area of sphere} = 4\pi r^2$$

$$S_2 = \text{Curved surface area of cylinder, } 2\pi r h = 2\pi r \times 2r = 4\pi r^2$$

$$S_3 = \text{Curved surface area of cone} = \pi r l = \pi r \times \sqrt{5} r = \sqrt{5} \pi r^2$$

∴ Ratio of curved surface area is

$$S_1 : S_2 : S_3 = 4\pi r^2 : 4\pi r^2 : \sqrt{5} \pi r^2$$

$$= 4 : 4 : \sqrt{5}$$

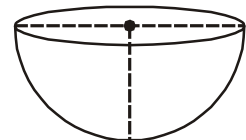
Example-4. A company wants to manufacture 1000 hemispherical basins from a thick steel sheet. If the radius of each basin is 21 cm., find the area of steel sheet required to manufacture the above hemispherical basins?

Solution : Radius of the hemispherical basin (r) = 21 cm

Surface area of a hemispherical basin = $2\pi r^2$

$$= 2 \times \frac{22}{7} \times 21 \times 21$$

$$= 2772 \text{ cm}^2.$$



Hence, curved surface area of hemispherical basin = 2772 cm^2

Area of the steel sheet required for one basin = 2772 cm^2

Total area of steel sheet required for 1000 basins = 2772×1000

$$= 2772000 \text{ cm}^2$$

$$= 277.2 \text{ m}^2$$

Example-5. A right circular cylinder has base radius 14cm and height 21cm.

- Find its (i) area of base (or area of each end) (ii) curved surface area
(iii) total surface area and (iv) volume of the right circular cylinder

Solution : Radius of the cylinder (r) = 14cm

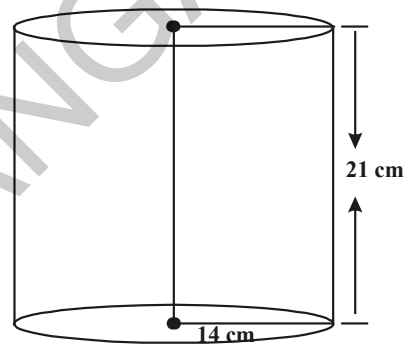
Height of the cylinder (h) = 21cm

Now (i) Area of base (area of each end) $\pi r^2 = \frac{22}{7} (14)^2$
 $= 616 \text{ cm}^2$

(ii) Curved surface area = $2\pi r h = 2 \times \frac{22}{7} \times 14 \times 21$
 $= 1848 \text{ cm}^2$.

(iii) Total surface area = $2 \times \text{area of the base} + \text{curved surface area}$
 $= 2 \times 616 + 1848 = 3080 \text{ cm}^2$.

(iv) Volume of cylinder = $\pi r^2 h = \text{area of the base} \times \text{height}$
 $= 616 \times 21 = 12936 \text{ cm}^3$.



Example-6. Find the volume and surface area of a sphere of radius 2.1 cm (take $\pi = \frac{22}{7}$)

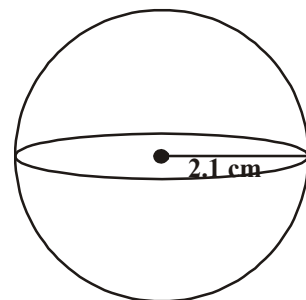
Solution : Radius of sphere (r) = 2.1 cm

Surface area of sphere = $4\pi r^2$

$$= 4 \times \frac{22}{7} \times (2.1)^2 = 4 \times \frac{22}{7} \times \frac{21}{10} \times \frac{21}{10}$$
$$= \frac{1386}{25} = 55.44 \text{ cm}^2$$

Volume of sphere = $\frac{4}{3} \pi r^3 = \frac{4}{3} \times \frac{22}{7} \times (2.1)^3$

$$= \frac{4}{3} \times \frac{22}{7} \times 2.1 \times 2.1 \times 2.1 = 38.808 \text{ cm}^3$$



Example-7. Find the volume and the total surface area of a hemisphere of radius 3.5 cm.

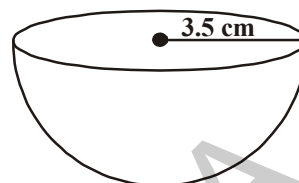
Solution : Radius of sphere (r) is $3.5 \text{ cm} = \frac{7}{2} \text{ cm}$

$$\text{Volume of hemisphere} = \frac{2}{3} \pi r^3$$

$$= \frac{2}{3} \times \frac{22}{7} \times \frac{7}{2} \times \frac{7}{2} \times \frac{7}{2} = \frac{539}{6} = 89.83 \text{ cm}^3$$

$$\text{Total surface area} = 3\pi r^2$$

$$= 3 \times \frac{22}{7} \times \frac{7}{2} \times \frac{7}{2} = \frac{231}{2} = 115.5 \text{ cm}^2$$



Exercise - 10.1

1. A joker's cap is in the form of right circular cone whose base radius is 7cm and height is 24 cm. Find the area of the sheet required to make 10 such caps.
2. A sports company was ordered to prepare 100 paper cylinders for packing shuttle cocks. The required dimensions of the cylinder are 35 cm length /height and its radius is 7 cm. Find the required area of thick paper sheet needed to make 100 cylinders?
3. Find the volume of right circular cone with radius 6 cm. and height 7cm.
4. The curved surface area of a cylinder is equal to the curved surface area of a cone. If the radii of their bases are the same, find the ratio of the height of the cylinder to the slant height of the cone.
5. A self help group wants to manufacture joker's caps of 3cm. radius and 4 cm. height. If the available paper sheet is 1000 cm^2 , then how many caps can be manufactured from that paper sheet?
6. A cylinder and cone have bases of equal radii and are of equal heights. Show that their volumes are in the ratio of 3:1.
7. The shape of solid iron rod is cylindrical. Its height is 11 cm. and base diameter is 7cm. Then find the total volume of 50 such rods.



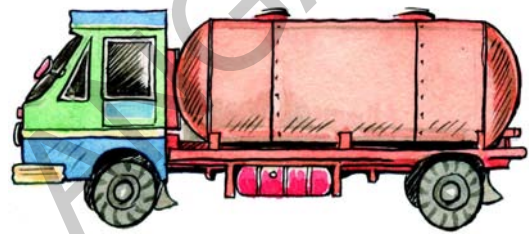
8. A heap of rice is in the form of a cone of diameter 12 m. and height 8 m. Find its volume?
How much canvas cloth is required to cover the heap ? (Use $\pi = 3.14$)
9. The curved surface area of a cone is 4070 cm^2 and diameter of its base is 70 cm. What is its slant height?

10.2 Surface Area of the Combination of Solids

We have seen solids which are made up of combination of solids known like sphere, cylinder and cone. We can observe in our real life also like wooden things, house items, medicine capsules, bottles, oil-tankers etc. We eat ice-cream in our daily life. Can you tell how many solid figures are there in it? It is usually made up of cone and hemisphere.

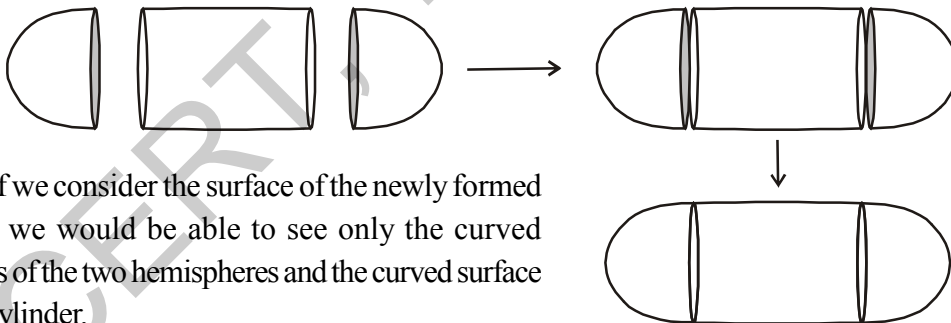


Lets take another example, an oil-tanker / water-tanker. Is it a single shaped object? You may guess that it is made up of a cylinder with two hemispheres at its ends.



If you want to find the surface areas or volumes or capacities of such objects, how would you do it? We cannot classify these shapes under any of the solids you have already studied.

As we have seen, the oil-tanker was made up of a cylinder with two hemispheres stuck at either end. It will look like the following figure:



If we consider the surface of the newly formed object, we would be able to see only the curved surfaces of the two hemispheres and the curved surface of the cylinder.

TSA of new solid = CSA of one hemisphere + CSA of cylinder + CSA of other hemisphere

Here, TSA and CSA stand for 'total surface area' and 'curved surface area' respectively. Now let us look at another example.



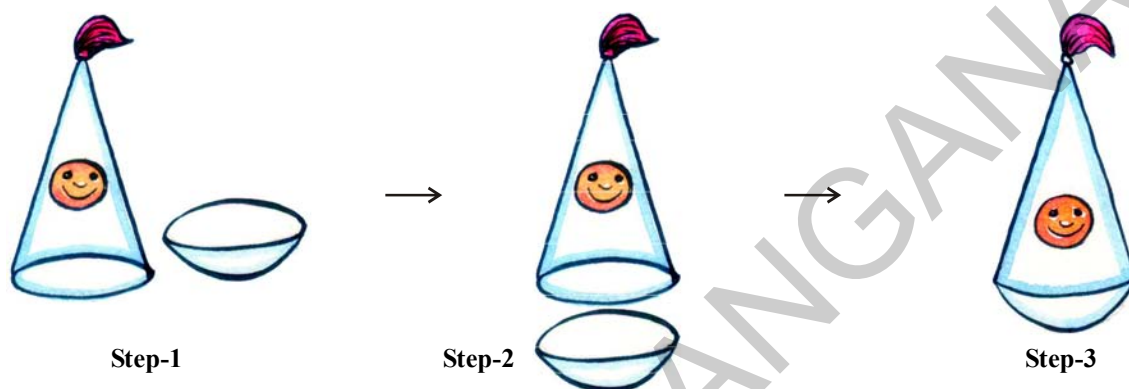
Think and Discuss

Saniya prepared a toy. She mounted a cone on a cylinder whose circular radii are same as shown in the figure. She told to Archana that the total surface area of the toy is the sum of the total surface areas of the cone and cylinder. Do you agree with this? Justify your answer.



Suppose, we want to make a toy by putting together a hemisphere and a cone. Let us see the steps that we should be going through.

First, we should take a cone and hemisphere of equal radii and bring their flat faces together. Here, of course, we should take the base radius of the cone equal to the radius of the hemisphere, for the toy to have a smooth surface. So, the steps would be as shown below:



At the end, we got a nice round-bottomed toy. Now, if we want to find how much paint we are required to colour the surface of the toy, for this we need to know the total surface area of the toy, which consists of the CSA of the hemisphere and the CSA of the cone.

$$\text{TSA of the toy} = \text{CSA of hemisphere} + \text{CSA of cone}$$



Try This

- Use known solid shapes and make as many objects (by combining more than two) as possible that you come across in your daily life.

[Hint : Use clay, or balls, pipes, paper cones, boxes like cube, cuboid etc]

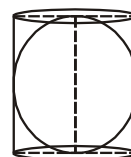


Think and Discuss

A sphere is inscribed in a cylinder.

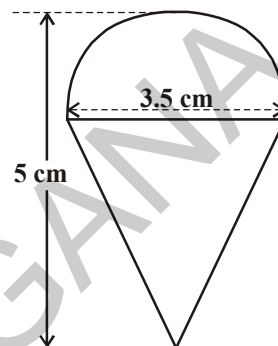
- What is the ratio of total surface areas of cylinder and sphere?
- What is the ratio of volumes of cylinder and sphere?

What have you observed?



Example-8. Koushik got a playing top as his birthday present, which surprisingly had no colour on it. He wanted to colour it with his crayons. The top is shaped like a cone surmounted by a hemisphere. The entire top is 5cm. in height and the diameter of the top is 3.5cm. Find the area he has to colour. (Take $\pi = \frac{22}{7}$)

Solution : This top is exactly like the object, that the combination of a cone and hemisphere having equal radii of circular base.



i.e. TSA of the toy =

CSA of hemisphere + CSA of cone

Now, the curved surface area of the hemisphere

$$= \frac{1}{2}(4\pi r^2) = 2\pi r^2$$

$$= \left(2 \times \frac{22}{7} \times \frac{3.5}{2} \times \frac{3.5}{2}\right) \text{cm}^2$$

Also, the height of the cone = height of the top – height (radius) of the hemispherical part

$$= \left(5 - \frac{3.5}{2}\right) = 3.25 \text{cm}$$

So, the slant height of the cone

$$l = \sqrt{r^2 + h^2} = \sqrt{\left(\frac{3.5}{2}\right)^2 + (3.25)^2} = 3.7 \text{cm} \quad (\text{approx.})$$

Therefore, CSA of cone = $\pi rl = \left(\frac{22}{7} \times \frac{3.5}{2} \times 3.7\right) \text{cm}^2$

this gives the surface area of the top as

$$= \left(2 \times \frac{22}{7} \times \frac{3.5}{2} \times \frac{3.5}{2}\right) \text{cm}^2 + \left(\frac{22}{7} \times \frac{3.5}{2} \times 3.7\right) \text{cm}^2$$

$$= \frac{22}{7} \times \frac{3.5}{2} (3.5 + 3.7) \text{cm}^2 = \frac{11}{2} \times (3.5 + 3.7) \text{cm}^2$$

$$= 39.6 \text{cm}^2 \quad (\text{approx.})$$

Note: You may not that surface area of the top is not the sum of the total surface area of the cone and hemisphere.



Example-9. A wooden toy rocket is in the shape of a cone mounted on a cylinder as shown in the adjacent figure. The height of the entire rocket is 26 cm, while the height of the conical part is 6 cm. The base of the conical position has a diameter of 5 cm, while the base diameter of the cylindrical portion is 3 cm. If the conical portion is to be painted orange and the cylindrical portion is to be painted yellow, find the area of the rocket painted with each of these color (Take $\pi = 3.14$)

Solution : Let 'r' be the radius of the base of the cone and its slant height be 'l'.

Further, let r_1 be the radius of cylinder and h_1 be its height

We have,

$$r = 2.5 \text{ cm.}, h = 6 \text{ cm.}$$

$$r_1 = 1.5 \text{ cm.} \quad h_1 = 20 \text{ cm.}$$

$$\text{Now, } l = \sqrt{r^2 + h^2}$$

$$\Rightarrow l = \sqrt{(2.5)^2 + 6^2}$$

$$l = \sqrt{6.25 + 36} = \sqrt{42.25} = 6.5$$

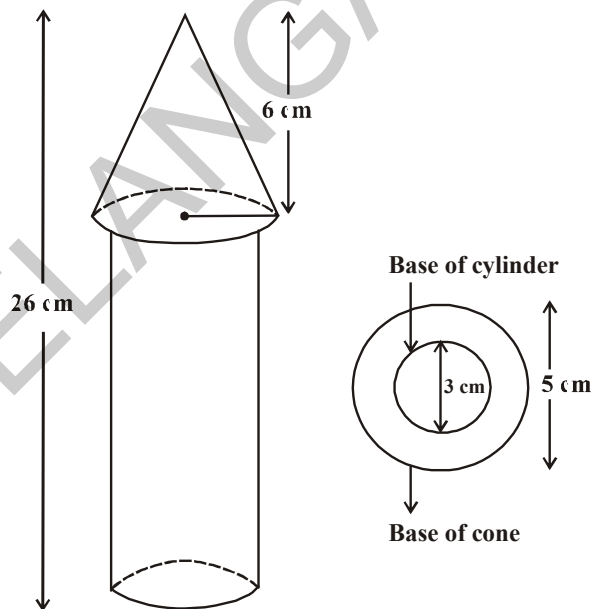
Now, area to be painted in orange =

CSA of the cone + base area of the cone -
base area of the cylinder

$$\begin{aligned} &= \pi r l + \pi r^2 - \pi r_1^2 \\ &= \pi[(2.5 \times 6.5) + (2.5)^2 - (1.5)^2] \text{ cm}^2 \\ &= \pi(20.25) \text{ cm}^2 = 3.14 \times 20.25 \text{ cm}^2 \\ &= 63.585 \text{ cm}^2 \end{aligned}$$

Area to be painted yellow

$$\begin{aligned} &= \text{Curved surface area of the cylinder} + \text{Area of the base of the cylinder} \\ &= 2\pi r_1 h_1 + \pi r_1^2 \\ &= \pi r_1 (2h_1 + r_1) \\ &= 3.14 \times 1.5 (2 \times 20 + 1.5) \text{ cm}^2 \end{aligned}$$



$$\begin{aligned}
 &= 3.14 \times 1.5 \times 41.5 \text{ cm}^2 \\
 &= 4.71 \times 41.5 \text{ cm}^2 \\
 &= 195.465 \text{ cm}^2.
 \end{aligned}$$

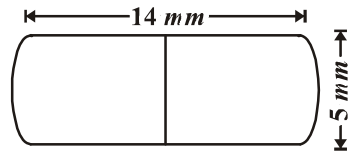
Therefore, area to be painted yellow = 195.465 cm^2



Exercise - 10.2

1. A toy is in the form of a cone mounted on a hemisphere of the same diameter. The diameter of the base and the height of the cone are 6 cm and 4 cm respectively. Determine the surface area of the toy. [use $\pi = 3.14$]
2. A solid is in the form of a right circular cylinder with a hemisphere at one end and a cone at the other end. The radius of the common base is 8 cm, and the heights of the cylindrical and conical portions are 10 cm and 6 cm respectively. Find the total surface area of the solid. [use $\pi = 3.14$]

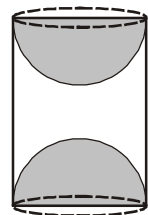
3. A medicine capsule is in the shape of a cylinder with two hemispheres stuck to each of its ends. The length of the capsule is 14 mm, and the thickness is 5 mm. Find its surface area.



4. Two cubes each of volume 64 cm^3 are joined end to end together. Find the surface area of the resulting cuboid.
5. A water tank consists of a circular cylinder with a hemisphere on either end. If the external diameter of the cylinder be 1.4 m, and its length be 8 m, then find the cost of painting it on the outside at rate of ₹20 per m^2 .
6. A sphere, a cylinder and a cone have the same radius and same height. Find the ratio of their volumes.

[Hint : Diameter of the sphere is equal to the heights of the cylinder and the cone.]

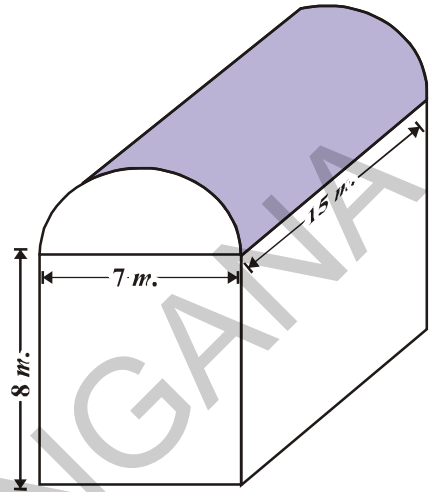
7. A hemisphere is cut out from one face of a cubical wooden block such that the diameter of the hemisphere is equal to the side of the cube. Determine the total surface area of the remaining solid.
8. A wooden article was made by scooping out a hemisphere from each end of a solid cylinder, as shown in the figure. If the height of the cylinder is 10 cm, and its radius of the base is of 3.5 cm, find the total surface area of the article.



10.3 Volume of Combination of Solids

Let us understand volume of a combined solid through an example.

Suresh runs an industry in a shed which is in the shape of a cuboid surmounted by a half cylinder. The base of the shed is of dimensions 7 m. \times 15 m. and the height of the cuboidal portion is 8 m. Find the volume of air that the shed can hold? Further, suppose the machinery in the shed occupies a total space of 300 m³ and there are 20 workers, each of whom occupies about 0.08 m³ space on an average. Then how much air is in the shed ?



The volume of air inside the shed (when there are neither people nor machinery) is given by the volume of air inside the cuboid and inside the half cylinder taken together. The length, breadth and height of the cuboid are 15 m., 7 m. and 8 m. respectively. Also the diameter of the half cylinder is 7 m. and its height is 15 m.

So, the required volume = volume of the cuboid + $\frac{1}{2}$ volume of the cylinder.

$$= \left[15 \times 7 \times 8 + \frac{1}{2} \times \frac{22}{7} \times \frac{7}{2} \times \frac{7}{2} \times 15 \right] \text{m}^3$$

$$= 1128.75 \text{m}^3.$$

Next, the total space occupied by the machinery = 300 m³.

And the total space occupied by the workers = 20 \times 0.08 m³
= 1.6 m³

Therefore, the volume of the air, inside the shed when there are machinery and workers

$$= 1128.75 - (300.00 + 1.60)$$

$$= 1128.75 - 301.60 = 827.15 \text{m}^3$$

Note : In calculating the surface area of combination of solids, we can not add the surface areas of the two solids because some part of the surface areas disappears or coincides in the process of joining them. However, this will not be the case when we calculate the volume. The volume of the solid formed by joining two basic solids will actually be the sum of the volumes of the constituents (as seen in the example above).





Try This

1. If the diameter of the cross - section of a wire is decreased by 5%, by what percentage should the length be increased so that the volume remains the same ?
2. Surface areas of a sphere and cube are equal. Then find the ratio of their volumes.

Let us see some more examples.

Example-10. A solid toy is in the form of a right circular cylinder with hemispherical shape at one end and a cone at the other end. Their common diameter is 4.2 cm and the height of the cylindrical and conical portions are 12cm and 7cm respectively. Find the volume of the solid toy.

(Use $\pi = \frac{22}{7}$).

Solution : Let height of the conical portion $h_1 = 7$ cm

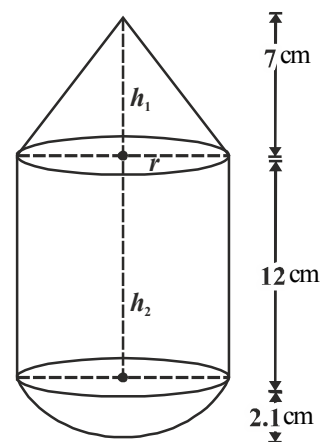
The height of cylindrical portion $h_2 = 12$ cm

$$\text{Radius } (r) = \frac{4.2}{2} = 2.1 = \frac{21}{10} \text{ cm}$$

Volume of the solid toy

= Volume of the Cone + Volume of the Cylinder + Volume of the Hemisphere.

$$\begin{aligned} &= \frac{1}{3} \pi r^2 h_1 + \pi r^2 h_2 + \frac{2}{3} \pi r^3 \\ &= \pi r^2 \left[\frac{1}{3} h_1 + h_2 + \frac{2}{3} r \right] \\ &= \frac{22}{7} \times \left(\frac{21}{10} \right)^2 \times \left[\frac{1}{3} \times 7 + 12 + \frac{2}{3} \times \frac{21}{10} \right] \\ &= \frac{22}{7} \times \frac{441}{100} \times \left[\frac{7}{3} + \frac{12}{1} + \frac{7}{5} \right] \\ &= \frac{22}{7} \times \frac{441}{100} \times \left[\frac{35 + 180 + 21}{15} \right] \\ &= \frac{22}{7} \times \frac{441}{100} \times \frac{236}{15} = \frac{27258}{125} = 218.064 \text{ cm}^3. \end{aligned}$$



Example-11. A cylindrical container is filled with ice-cream whose diameter is 12 cm and height is 15 cm. The whole ice cream is distributed to 10 children by filling in equal cones and forming hemispherical tops. If the height of the conical portion is twice the diameter of its base, find the diameter of the ice cream cone.

Solution : Let the radius of the base of conical ice cream = x cm

$$\therefore \text{diameter} = 2x \text{ cm}$$

Then, the height of the conical ice cream

$$= 2 (\text{diameter}) = 2(2x) = 4x \text{ cm}$$

Volume of ice cream cone

$$= \text{Volume of conical portion} + \text{Volume of hemispherical portion}$$

$$= \frac{1}{3} \pi r^2 h + \frac{2}{3} \pi r^3$$

$$= \frac{1}{3} \pi x^2 (4x) + \frac{2}{3} \pi x^3$$

$$= \frac{4\pi x^3 + 2\pi x^3}{3} = \frac{6\pi x^3}{3}$$

$$= 2\pi x^3 \text{ cm}^3$$

Diameter of cylindrical container = 12 cm

Its height (h) = 15 cm

$$\therefore \text{Volume of cylindrical container} = \pi r^2 h$$

$$= \pi(6)^2 15$$

$$= 540\pi \text{ cm}^3$$

Number of children to whom ice cream is given = 10

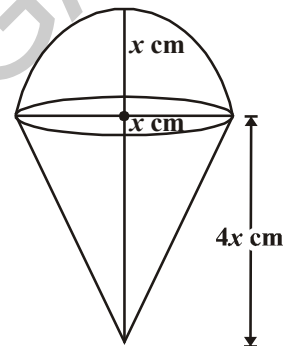
$$\frac{\text{Volume of cylindrical container}}{\text{Volume of one ice cream cone}} = 10$$

$$\Rightarrow \frac{540\pi}{2\pi x^3} = 10$$

$$2\pi x^3 \times 10 = 540\pi$$

$$\Rightarrow x^3 = \frac{540}{2 \times 10} = 27$$

$$\Rightarrow x^3 = 27$$



$$\Rightarrow x^3 = 3^3$$

$$\Rightarrow x = 3$$

\therefore Diameter of ice cream cone $2x = 2(3) = 6\text{cm}$

Example-12. A solid consisting of a right circular cone standing on a hemisphere, is placed upright in a right circular cylinder full of water and touching the bottom as shown in the adjacent figure. Find the volume of water left in the cylinder, given that the radius of the cylinder is 3 cm. and its height is 6cm. The radius of the hemisphere is 2 cm. and the height of the cone is 4 cm.

$$\left(\text{Take } \pi = \frac{22}{7} \right).$$

Solution : In the figure drawn here,

ABCD is a cylinder, LMN is a hemisphere and OLM is a cone

We know that when a solid is immersed in the water, then water displaced equal to the volume of the solid.

$$\text{Volume of the cylinder} = \pi r^2 h = \pi \times 3^2 \times 6 = 54 \pi \text{ cm}^3$$

$$\text{Volume of the hemisphere} = \frac{2}{3} \pi r^3 = \frac{2}{3} \times \pi \times 2^3 = \frac{16}{3} \pi \text{ cm}^3$$

$$\text{Volume of the cone} = \frac{1}{3} \pi r^2 h = \frac{1}{3} \times \pi \times 2^2 \times 4 = \frac{16}{3} \pi \text{ cm}^3$$

$$\text{Volume of the solid figure} = \frac{16}{3} \pi + \frac{16}{3} \pi$$

$$= \frac{32}{3} \pi$$

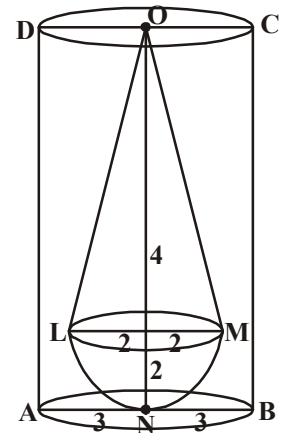
Volume of water left in the cylinder

$$= \text{Volume of Cylinder} - \text{Volume of solid figure immersed}$$

$$= 54\pi - \frac{32\pi}{3}$$

$$= \frac{162\pi - 32\pi}{3} = \frac{130\pi}{3}$$

$$= \frac{130}{3} \times \frac{22}{7} = \frac{2860}{21} = 136.19 \text{ cm}^3$$



Example-13. A cylindrical pencil is sharpened to produce a perfect cone at one end with no over all loss of its length. The diameter of the pencil is 1cm and the length of the conical portion is 2cm. Calculate the volume of the peels that are obtained after sharpening pencil.

Give your answer correct to two places if it is in decimal $\left[\text{use } \pi = \frac{355}{113} \right]$.

Solution : Diameter of the pencil = 1 cm

So, radius of the pencil (r) = 0.5 cm

Length of the conical portion = $h = 2$ cm

Volume of peels = Volume of cylinder of length 2 cm and base radius 0.5cm.

– volume of the cone formed by this cylinder

$$= \pi r^2 h - \frac{1}{3} \pi r^2 h = \frac{2}{3} \pi r^2 h$$

$$= \frac{2}{3} \times \frac{355}{113} \times (0.5)^2 \times 2 \text{ cm}^3 = 1.05 \text{ cm}^3$$

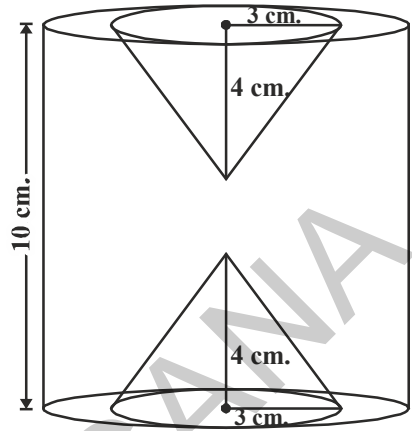


Exercise-10.3

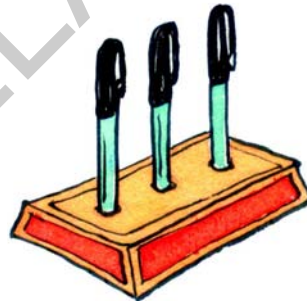
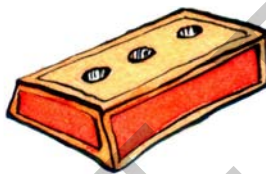
1. An iron pillar consists of a cylindrical portion of 2.8 m height and 20 cm in diameter and a cone of 42 cm height surmounting it. Find the weight of the pillar if 1 cm^3 of iron weighs 7.5 g.
2. A toy is made in the form of hemisphere surmounted by a right cone whose circular base is joined with the plane surface of the hemisphere. The radius of the base of the cone is 7 cm and its volume is $\frac{3}{2}$ of the hemisphere. Calculate the height of the cone and the surface area of the toy correct to 2 places of decimal $\left(\text{Take } \pi = 3\frac{1}{7} \right)$.
3. Find the volume of the largest right circular cone that can be cut out of a cube whose edge is 7 cm.



4. A cylindrical mug of radius 5 cm and height 9.8 cm is full of water. A solid in the form of right circular cone mounted on a hemisphere is immersed into the mug. The radius of the hemisphere is 3.5 cm and height of conical part 5 cm. Find the volume of water left in the tub $\left(\text{Take } \pi = \frac{22}{7} \right)$.



5. In the adjacent figure, the height of a solid cylinder is 10 cm and diameter is 7 cm. Two equal conical holes of radius 3 cm and height 4 cm are cut off as shown the figure. Find the volume of the remaining solid.
6. Spherical marbles of diameter 1.4 cm are dropped into a cylindrical beaker of diameter 7 cm, which contains some water. Find the number of marbles that should be dropped in to the beaker, so that water level rises by 5.6 cm.
7. A pen stand is made of wood in the shape of cuboid with three conical depressions to hold the pens. The dimensions of the cuboid are 15 cm by 10 cm by 3.5 cm. The radius of each of the depression is 0.5 cm and the depth is 1.4 cm. Find the volume of wood in the entire stand.



10.4 Conversion of Solid from One Shape to Another



A women self help group (DWACRA) prepares candles by melting down cuboid shape wax. In medicine factory, medicines in different shapes (spherical, capsules etc) are made by using bulk drug raw material which is in the shape of a cuboid / sphere. In gun factories, spherical bullets are made by melting solid cube of lead, goldsmith prepares various ornaments by melting cuboid gold biscuits. In all these cases, the shapes of solids are converted into another shapes. In this process, the volume always remains the same.

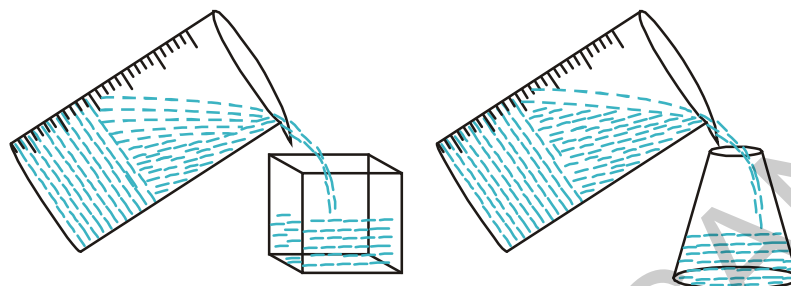
How does this happen? If you want a candle of any special shape, you have to heat the wax in metal container till it is completely melted.

Then, you pour it into another container which has the special shape that you wanted.

For example, lets us take a candle in the shape of solid cylinder, melt it and pour whole of the molten wax into another container shaped like a sphere. On cooling, you will obtain a candle in the shape of the sphere.

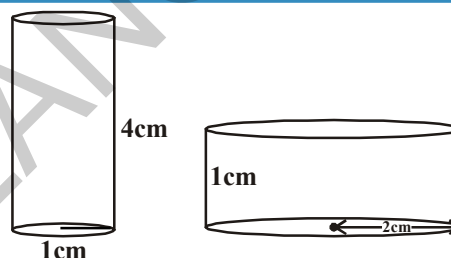


The volume of the new candle will be the same as the volume of the earlier candle. This is what we have to remember when we come across objects which are converted from one shape to another, or when a type of liquid which originally filled a container of a particular shape is poured into another container of a different shape or size as you observe in the following figures.



Think and Discuss

Which barrel shown in the adjacent figure can hold more water? Discuss with your friends.



To understand what has been discussed, let us consider some examples.

Example-14. A cone of height 24cm and radius of base 6cm is made up of modelling clay. A child moulds it in the form of a sphere. Find the radius of the sphere.

Solution : Volume of cone = $\frac{1}{3} \times \pi \times 6 \times 6 \times 24 \text{ cm}^3$

If r is the radius of the sphere, then its volume is $\frac{4}{3} \pi r^3$

Since, the volume of clay in the form of the cone and the sphere remains the same, we have

$$\frac{4}{3} \pi r^3 = \frac{1}{3} \pi \times 6 \times 6 \times 24$$

$$r^3 = 3 \times 3 \times 24 = 3 \times 3 \times 3 \times 8$$

$$r^3 = 3^3 \times 2^3$$

$$r = 3 \times 2 = 6$$

Therefore, the radius of the sphere is 6cm.





Do This

1. A copper rod of diameter 1 cm. and length 8 cm. is drawn into a wire of length 18m of uniform thickness. Find the thickness of the wire.
2. Pravali's house has a water tank in the shape of a cylinder on the roof. This is filled by pumping water from a sump (an under ground tank) which is in the shape of a cuboid. The sump has dimensions 1.57 m. \times 1.44 m. \times 1.5 m. The water tank has radius 60 cm. and height 95 cm. Find the height of the water left in the sump after the water tank has been completely filled with water from the sump which had been full of water. Compare the capacity of the tank with that of the sump. ($\pi = 3.14$)

Example-15. The diameter of the internal and external surfaces of a hollow hemispherical shell are 6 cm. and 10 cm. respectively. It is melted and recast into a solid cylinder of diameter 14 cm. Find the height of the cylinder.

Solution : Outer radius of hollow hemispherical shell (R) = $\frac{10}{2} = 5$ cm.

Internal radius of hollow hemispherical shell (r) = $\frac{6}{2} = 3$ cm.

Volume of hollow hemispherical shell
= External volume - Internal volume

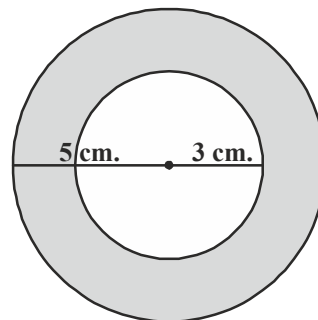
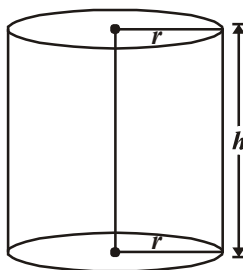
$$= \frac{2}{3} \pi R^3 - \frac{2}{3} \pi r^3$$

$$= \frac{2}{3} \pi (R^3 - r^3)$$

$$= \frac{2}{3} \pi (5^3 - 3^3)$$

$$= \frac{2}{3} \pi (125 - 27)$$

$$= \frac{2}{3} \pi \times 98 \text{ cm}^3 = \frac{196\pi}{3} \text{ cm}^3 \quad \dots(1)$$



Since, this hollow hemispherical shell is melted and recast into a solid cylinder. So their volumes must be equal

Diameter of cylinder = 14 cm. (Given)

So, radius of cylinder = 7 cm.



Let the height of cylinder = h

$$\begin{aligned}\therefore \text{volume of cylinder} &= \pi r^2 h \\ &= \pi \times 7 \times 7 \times h \text{ cm}^3 = 49\pi h \text{ cm}^3 \quad \dots(2)\end{aligned}$$

According to given condition

volume of hollow hemispherical shell = volume of solid cylinder

$$\begin{aligned}\frac{196}{3}\pi &= 49\pi h \quad [\text{From equatiion (1) and (2)}] \\ \Rightarrow h &= \frac{196}{3 \times 49} = \frac{4}{3} \text{ cm.}\end{aligned}$$

Hence, height of the cylinder = 1.33 cm.

Example-16. A hemispherical bowl of internal radius 15 cm contains a liquid. The liquid is to be filled into cylindrical bottles of diameter 5 cm and height 6 cm. How many bottles are necessary to empty the bowl ?

Solution : Volume of hemisphere = $\frac{2}{3}\pi r^3$

Internal radius of hemisphere $r = 15$ cm

\therefore Volume of liquid contained in hemispherical bowl

$$\begin{aligned}&= \frac{2}{3}\pi(15)^3 \text{ cm}^3 \\ &= 2250\pi \text{ cm}^3.\end{aligned}$$

This liquid is to be filled in cylindrical bottles and the height of each bottle (h) = 6 cm.

and radius (R) = $\frac{5}{2}$ cm

\therefore Volume of 1 cylindrical bottle = $\pi R^2 h$

$$\begin{aligned}&= \pi \times \left(\frac{5}{2}\right)^2 \times 6 \\ &= \pi \times \frac{25}{4} \times 6 \text{ cm}^3 = \frac{75}{2}\pi \text{ cm}^3.\end{aligned}$$

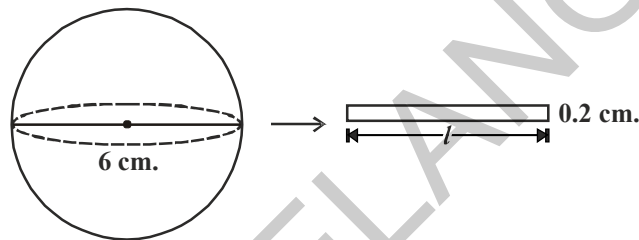


$$\begin{aligned} \text{Number of cylindrical bottles required} &= \frac{\text{Volume of hemispherical bowl}}{\text{Volume of 1 cylindrical bottle}} \\ &= \frac{2250\pi}{\frac{75}{2}\pi} = \frac{2 \times 2250}{75} = 60. \end{aligned}$$

Example-17. The diameter of a metallic sphere is 6 cm. It is melted and drawn into a long wire having a circular cross section of diameter as 0.2 cm. Find the length of the wire.

Solution : Diameter of metallic sphere = 6 cm

\therefore Radius of metallic sphere = 3 cm



Now, diameter of cross section of cylindrical wire = 0.2 cm.

\therefore Radius of cross section of cylinder wire = 0.1 cm.

Let the length of wire be l cm.

Since the metallic sphere is converted into a cylindrical shaped wire of length l cm it can be considered as its height.

Volume of the metal used in wire = Volume of the sphere

$$\pi \times (0.1)^2 \times h = \frac{4}{3} \times \pi \times 3^3$$

$$\pi \times \left(\frac{1}{10}\right)^2 \times h = \frac{4}{3} \times \pi \times 27$$

$$\pi \times \frac{1}{100} \times h = 36\pi$$

$$h = \frac{36\pi \times 100}{\pi} \text{ cm}$$

$$= 3600 \text{ cm} = 36 \text{ m } (\because 1 \text{ m} = 100 \text{ cm})$$

Therefore, the length of the wire is 36 m.

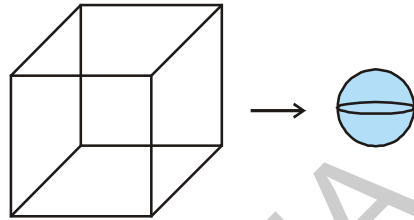


Example-18. How many spherical balls can be made out of a solid cube of lead whose edge measures 44 cm and each ball being 4 cm. in diameter.

Solution : Side of lead cube = 44 cm.

$$\text{Radius of spherical ball} = \frac{4}{2} \text{ cm.} = 2 \text{ cm.}$$

$$\begin{aligned} \text{Now volume of a spherical ball} &= \frac{4}{3} \pi r^3 \\ &= \frac{4}{3} \times \frac{22}{7} \times 2^3 \text{ cm}^3 \\ &= \frac{4}{3} \times \frac{22}{7} \times 8 \text{ cm}^3 \end{aligned}$$



Let the number of balls be 'x'.

$$\text{Volume of } x \text{ spherical ball} = \frac{4}{3} \times \frac{22}{7} \times 8 \times x \text{ cm}^3$$

It is clear that volume of x spherical balls = Volume of lead cube

$$\Rightarrow \frac{4}{3} \times \frac{22}{7} \times 8 \times x = (44)^3$$

$$\Rightarrow \frac{4}{3} \times \frac{22}{7} \times 8 \times x = 44 \times 44 \times 44$$

$$\Rightarrow x = \frac{44 \times 44 \times 44 \times 3 \times 7}{4 \times 22 \times 8}$$

$$x = 2541$$

Hence, total number of spherical balls = 2541.



Example-19. A women self help group (DWACRA) is supplied a rectangular solid (cuboid shape) of wax block with dimensions 66 cm, 42 cm, 21 cm, to prepare cylindrical candles each 4.2 cm in diameter and 2.8 cm of height. Find the number of candles prepared using this solid.

Solution : Volume of wax in the rectangular solid = $l b h$

$$= (66 \times 42 \times 21) \text{ cm}^3.$$

$$\text{Radius of cylindrical candle} = \frac{4.2}{2} \text{ cm.} = 2.1 \text{ cm.}$$

Height of cylindrical candle = 2.8 cm.



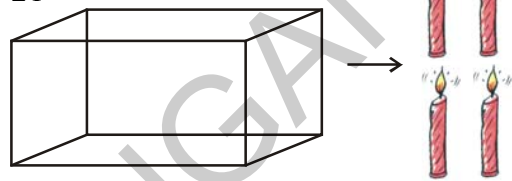
$$\begin{aligned}\text{Volume of candle} &= \pi r^2 h \\ &= \frac{22}{7} \times (2.1)^2 \times 2.8\end{aligned}$$

Let x be the number of candles

$$\text{Volume of } x \text{ cylindrical wax candles} = \frac{22}{7} \times 2.1 \times 2.1 \times 2.8 \times x$$

\therefore Volume of x cylindrical candles = volume of wax in rectangular shape

$$\begin{aligned}\frac{22}{7} \times 2.1 \times 2.1 \times 2.8 \times x &= 66 \times 42 \times 21 \\ x &= \frac{66 \times 42 \times 21 \times 7}{22 \times 2.1 \times 2.1 \times 2.8} \\ &= 1500\end{aligned}$$



Hence, the number of cylindrical wax candles that can be prepared is 1500.



Exercise - 10.4

1. A metallic sphere of radius 4.2 cm is melted and recast into the shape of a cylinder of radius 6 cm. Find the height of the cylinder.
2. Three metallic spheres of radii 6 cm, 8 cm and 10 cm respectively are melted together to form a single solid sphere. Find the radius of the resulting sphere.
3. A 20 m deep well of diameter 7 m is dug and the earth got by digging is evenly spread out to form a rectangular platform of base 22 m \times 14 m. Find the height of the platform.
4. A well of diameter 14 m is dug 15 m deep. The earth taken out of it has been spread evenly to form circular embankment all around the well of width 7 m. Find the height of the embankment.
5. A container shaped a right circular cylinder having diameter 12 cm and height 15 cm is full of ice cream. The ice cream is to be filled into cones of height 12 cm and diameter 6 cm, making a hemispherical shape on the top. Find the number of such cones which can be filled with ice cream.
6. How many silver coins, 1.75 cm in diameter and thickness 2 mm, need to be melted to form a cuboid of dimensions 5.5 cm \times 10 cm \times 3.5 cm?
7. A vessel is in the form of an inverted cone. Its height is 8 cm. and the radius of its top is 5 cm. It is filled with water upto the rim. When lead shots, each of which is a sphere of radius 0.5 cm are dropped into the vessel, $\frac{1}{4}$ of the water flows out. Find the number of lead shots dropped into the vessel.
8. A solid metallic sphere of diameter 28 cm is melted and recast into a number of smaller cones, each of diameter $4\frac{2}{3}$ cm and height 3 cm. Find the number of cones so formed.





Optional Exercise

[For extensive Learning]

1. A golf ball has diameter equal to 4.1 cm. Its surface has 150 dimples each of radius 2 mm. Calculate total surface area which is exposed to the surroundings. (Assume that the dimples are all hemispherical) $\left[\pi = \frac{22}{7} \right]$
2. A cylinder of radius 12 cm contains water to a depth of 20 cm. When a spherical iron ball is dropped in to the cylinder, the level of water is raised by 6.75 cm. Find the radius of the ball. $\left[\pi = \frac{22}{7} \right]$
3. Three metal cubes with edges 15 cm., 12 cm. and 9 cm. respectively are melted together and formed into a single cube. Find the diagonal of this cube.
4. A hemispherical bowl of internal diameter 36 cm. contains a liquid. This liquid is to be filled in cylindrical bottles of radius 3 cm. and height 6 cm. How many bottles are required to empty the bowl?

Suggested Projects

Make an open box from a 20cm by 20cm piece of cardboard by cutting out four squares from corners folding the flaps.

- What is the biggest volume of box you can make in this way?
- Can you find a relation between the size of paper and the size of the square cutout that produces the maximum volume.

Extension: You can extend this by taking a rectangular sheet of paper instead of a square sheet of paper.



What We Have Discussed

1. The volume of the solid formed by joining two or more basic solids is the sum of the volumes of the constituents.
2. In calculating the surface area of a combination of solids, we can not add the surface area of the two constituents because some part of the surface area disappears on joining them.



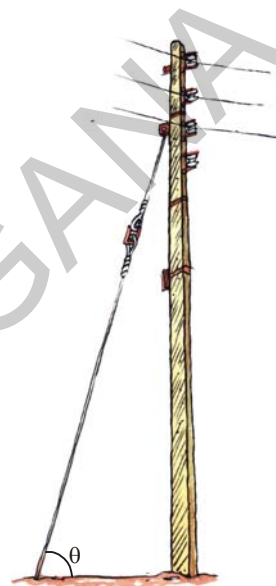


11.1 Introduction

We have learnt about triangles and their properties in previous classes. There, we observed different daily life situations where triangles are used.

Let's again look at some of the daily life examples.

- Electric poles are present everywhere. They are usually setup by using a metal wire. The pole, wire and the ground form a triangle. But, if the length of the wire decreases, will there a change in the angle of the wire with the ground ?



- A person is whitewashing a wall with the help of a ladder which is kept as shown in the figure. If the person wants to paint at a higher position, what will the person do? What will be the change in angle of the ladder with the ground ?

- In the temple at Jainath in Adilabad district, which was built in 13th century, the first rays of the Sun fall at the feet of the Idol of Suryanarayana Swami in the month of December. Is there a relation between distance of Idol from the door, height of the hole on the door from which Sun rays are entering and angle of sun rays in that month?

- You might have observed children sliding on a slider in a play ground. Sliding nature of a slider depends upon the angle made by it with the ground. What happens if the angle made by by slider with the ground changes? If this angle is abnormal, will children be able to play on it?



The above examples are showing the application part of geometry in our daily life and we can measure the heights, distances and slopes by using the properties of triangles. These types of problems are part of ‘trigonometry’ which is a branch of mathematics.

Now, look at the example of a person who is white washing the wall with the help of a ladder. Let us observe the following situations.

We denote the foot of the ladder by A and top of it by C and the point of intersection of the wall and line through base of the ladder as B. Therefore, ΔABC is a right angled triangle with right angle at B. Let the angle between ladder and base be θ .

1. If the person wants to white wash at a higher point on the wall-

- What happens to the angle made by the ladder with the ground?
- What will be the change in the distance AB?

2. If the person wants to white wash at a lower point on the wall-

- What happens to the angle made by the ladder with the ground?
- What will be the change in the distance AB?



In the above situation, if he wants to paint at a higher or lower point, he should change the position of ladder. So, when ‘ θ ’ is increased, the height also increases and the base distance AB decreases. But, when θ is decreased, the height also decreases and the base distance AB increases. Do you agree with this statement?

Here, we have seen a right angled triangle ΔABC . Now, let’s name the sides at a right triangle because trigonometric ratios give the relation between sides and angles.



11.1.1 Naming The Sides in a Right Triangle

Let's take a right triangle ABC right angled at B as show in the figure.

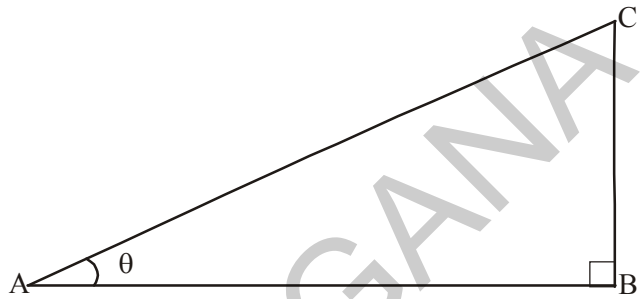
In triangle ABC, we can consider $\angle BAC$ as $\angle A$ and angle A is an acute angle. In this triangle, side AC is opposite to the right angle $\angle B$ and it is called "hypotenuse".

Here, do you observe the position of side BC with respect to angle A? It is opposite to angle A and we can call it as "**opposite side of angle A**". And the remaining side AB can be called as "**Adjacent side of angle A**"

AC = Hypotenuse

BC = Opposite side of angle A

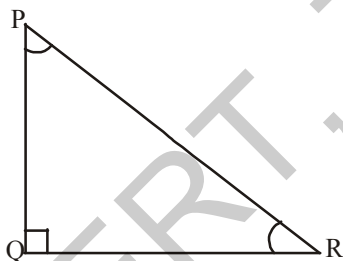
AB = Adjacent side of angle A



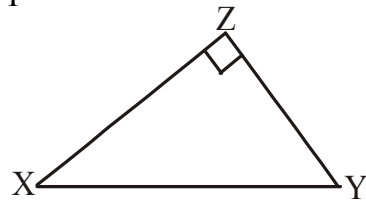
Do This

Identify "Hypotenuse", "Opposite side" and "Adjacent side" for the given angles in the given triangles.

1. For angle R



2. (i) For angle X
(ii) For angle Y

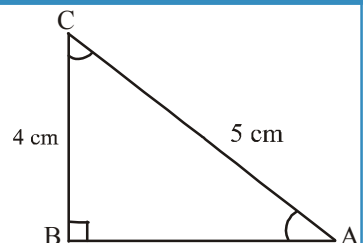


Try This

Write lengths of "Hypotenuse", "Opposite side" and "Adjacent side" for the given angles in the given triangle.

1. For angle C

2. For angle A



What do you observe? Is there any relation between the opposite side of the angle A and adjacent side of angle C? Like this, suppose you are setting up a pole by giving support of strong ropes. Is there any relationship between the length of the rope and the length of the pole? Here, we have to understand the relationship between the sides and angles we will study trigonometric ratios.



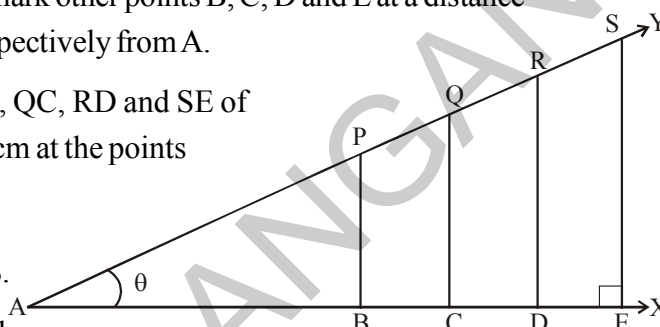
11.2 Trigonometric Ratios

We have seen some examples in the beginning of the chapter which are related to our daily life situations. Let's know about the trigonometric ratios and how they are defined.



Activity

1. Draw a horizontal line on a paper.
2. Let the initial point be A and mark other points B, C, D and E at a distance of 3cm, 6cm, 9cm, 12 cm respectively from A.
3. Draw the perpendiculars PB, QC, RD and SE of lengths 4cm, 8cm, 12cm, 16cm at the points B, C, D and E respectively.
4. Then join AP, PQ, QR and RS.
5. Find lengths of AP, AQ, AR and AS.



Name of triangle	Name of the angle	Length of hypotenuse	Length of opposite side	Length of adjacent side	$\frac{\text{Opposite side}}{\text{Hypotenuse}}$	$\frac{\text{Adjacent side}}{\text{Hypotenuse}}$
$\triangle ABP$	$\angle BAP = \theta$					
$\triangle ACQ$	$\angle CAQ = \theta$					
$\triangle ADR$						
$\triangle AES$						

Then find the ratios $\frac{BP}{AP}$, $\frac{CQ}{AQ}$, $\frac{DR}{AR}$ and $\frac{ES}{AS}$.

Did you get the same ratio as $\frac{4}{5}$?

Similarly try to find the ratios $\frac{AB}{AP}$, $\frac{AC}{AQ}$, $\frac{AD}{AR}$ and $\frac{AE}{AS}$? What do you observe?

Are these ratios constant for this fixed angle (θ) even though the sides are different?



11.2.1 Defining Trigonometric Ratios

In the above activity, when we observe right angled triangles $\triangle ABP$, $\triangle ACQ$, $\triangle ADR$ and $\triangle AES$, $\angle A$ is common, $\angle B$, $\angle C$, $\angle D$ and $\angle E$ are right angles and $\angle P$, $\angle Q$, $\angle R$ and $\angle S$ are also equal (why?). Hence, we can say that triangles $\triangle ABP$, $\triangle ACQ$, $\triangle ADR$ and $\triangle AES$ are similar triangles. When we observe the ratio of opposite side of angle A and hypotenuse in a right angled triangle and the ratio of corresponding sides in remaining triangles, is found to be constant.

The ratios $\frac{BP}{AP}$, $\frac{CQ}{AQ}$, $\frac{DR}{AR}$ and $\frac{ES}{AS}$ are named as “**sine A**” or simply “**sin A**” in those triangles. If the value of angle A is ‘ θ ’, then the ratio would be “ $\sin\theta$ ”.

Hence, we can conclude that the ratio of opposite side of an angle (other than right angle) and length of the hypotenuse is constant in all similar right angled triangles. This ratio will be named as “sine” of that angle.

Similarly, when we observe the ratios $\frac{AB}{AP}$, $\frac{AC}{AQ}$, $\frac{AD}{AR}$ and $\frac{AE}{AS}$, it is also found to be constant. And these are the ratios of the adjacent sides of the angle A and hypotenuses in right angled triangles $\triangle ABP$, $\triangle ACQ$, $\triangle ADR$ and $\triangle AES$. So, the ratios $\frac{AB}{AP}$, $\frac{AC}{AQ}$, $\frac{AD}{AR}$ and $\frac{AE}{AS}$ will be named as “**cosine A**” or simply “**cos A**” in those triangles. If the value of the angle A is “ θ ”, then the ratio would be “ $\cos\theta$ ”

Hence, we can also conclude that the ratio of the adjacent side of an angle (other than right angle) and length of the hypotenuse is constant in all similar right triangles. This ratio will be named as “cosine” of that angle.

Similarly, the ratio of opposite side and adjacent side of an angle is constant and it can be named as “tangent” of that angle.

Let's Define Ratios in a Right Angle Triangle

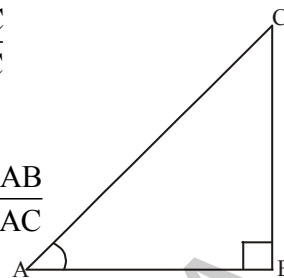
Consider a right angled triangle ABC having right angle at B as shown in the adjacent figure. Then, trigonometric ratios of the angle A are defined as follows :



$$\text{sine of } \angle A = \sin A = \frac{\text{Length of the side opposite to angle A}}{\text{Length of hypotenuse}} = \frac{BC}{AC}$$

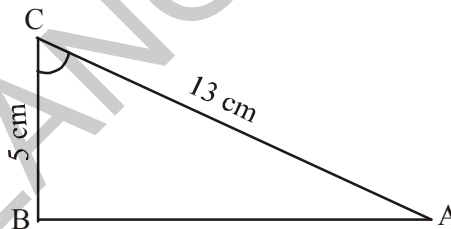
$$\text{cosine of } \angle A = \cos A = \frac{\text{Length of the side adjacent to angle A}}{\text{Length of hypotenuse}} = \frac{AB}{AC}$$

$$\text{tangent of } \angle A = \tan A = \frac{\text{Length of the side opposite to angle A}}{\text{Length of the side adjacent to angle A}} = \frac{BC}{AB}$$



Do This

- Find (i) $\sin C$ (ii) $\cos C$ and (iii) $\tan C$ in the adjacent triangle.
- In a triangle $\triangle XYZ$, $\angle Y$ is right angle, $XZ = 17$ m and $YZ = 15$ cm, then find (i) $\sin X$ (ii) $\cos Z$ (iii) $\tan X$
- In a triangle $\triangle PQR$, with right angle at Q , the value of $\angle P$ is x , $PQ = 7$ cm and $QR = 24$ cm, then find $\sin x$ and $\cos x$.



Try This

In a right angled triangle $\triangle ABC$, right angle is at C . $BC + CA = 23$ cm and $BC - CA = 7$ cm, then find $\sin A$ and $\tan B$.



Think and Discuss

Discuss among your friends

- Does $\sin x = \frac{4}{3}$ exist for some value of angle x ? How can you say?
- The value of $\sin A$ and $\cos A$ is always less than 1. Why?
- Is $\tan A$ product of \tan and A ? Justify your answer.



There are three more ratios defined in trigonometry which are considered as multiplicative inverses of the above three ratios.

Multiplicative inverse of “sine A” is “cosecant A”, simply written as “cosec A”, it is also some times written as $\csc A$ i.e., $\text{cosec} A = \frac{1}{\sin A}$

Similarly, multiplicative inverse of “cos A” is secant A” (simply written as “sec A”) and that of “tan A” is “cotangent A” (simply written as cot A)

$$\text{i.e., } \sec A = \frac{1}{\cos A} \text{ and } \cot A = \frac{1}{\tan A}$$

How can you define ‘cosec A’ in terms of sides?

$$\text{If } \sin A = \frac{\text{Opposite side of the angle } A}{\text{Hypotenuse}},$$

$$\text{then } \text{cosec} A = \frac{\text{Hypotenuse}}{\text{Opposite side of the angle } A}$$



Try This

Express $\sec A$ and $\cos A$ in terms of sides of right angled triangle.



Think and Discuss

- Is $\frac{\sin A}{\cos A} = \tan A$?
- Is $\frac{\cos A}{\sin A} = \cot A$?

Let us see some examples

Example-1. If $\tan A = \frac{3}{4}$, then find the other trigonometric ratio of angle A.

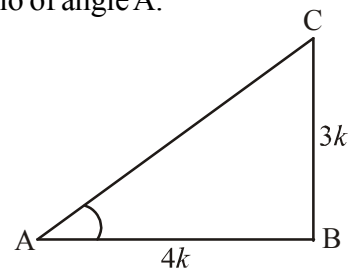
Solution : Given $\tan A = \frac{3}{4}$

$$\text{Hence } \tan A = \frac{\text{Opposite side}}{\text{Adjacent side}} = \frac{3}{4}$$

Therefore, opposite side : adjacent side = 3:4

For angle A, let opposite side = BC = $3k$ (where k is any positive number)

Adjacent side = AB = $4k$



Now, we have in triangle ABC (by Pythagoras theorem)

$$\begin{aligned} AC^2 &= AB^2 + BC^2 \\ &= (3k)^2 + (4k)^2 = 25k^2 \\ AC &= \sqrt{25k^2} \\ &= 5k = \text{Hypotenuse} \end{aligned}$$

Now, we can easily write the other ratios of trigonometry

$$\begin{aligned} \sin A &= \frac{3k}{5k} = \frac{3}{5}, \quad \cos A = \frac{4k}{5k} = \frac{4}{5} \\ \text{Hence cosec } A &= \frac{1}{\sin A} = \frac{5}{3}, \quad \sec A = \frac{1}{\cos A} = \frac{5}{4}, \quad \cot A = \frac{1}{\tan A} = \frac{4}{3}. \end{aligned}$$

Example-2. If $\angle A$ and $\angle P$ are acute angles such that $\sin A = \sin P$ then prove that $\angle A = \angle P$

Solution : Given $\sin A = \sin P$

From $\triangle ABC$, $\sin A = \frac{BC}{AC}$

From $\triangle PQR$, $\sin P = \frac{QR}{PQ}$

Then $\frac{BC}{AC} = \frac{QR}{PQ}$

Let, $\frac{BC}{AC} = \frac{QR}{PQ} = k \quad \dots(1)$

By using Pythagoras theorem

$$\frac{AB}{PR} = \frac{\sqrt{AC^2 - BC^2}}{\sqrt{PQ^2 - QR^2}} = \frac{\sqrt{AC^2 - k^2 AC^2}}{\sqrt{PQ^2 - k^2 PQ^2}} = \frac{\sqrt{AC^2 (1 - k^2)}}{\sqrt{PQ^2 (1 - k^2)}} = \frac{AC}{PQ} \quad (\text{From (1)})$$

$$\therefore \frac{AC}{PQ} = \frac{AB}{PR} = \frac{BC}{QR} \text{ then } \triangle ABC \sim \triangle PQR$$

Therefore, $\angle A = \angle P$

Example-3. Consider a triangle $\triangle PQR$, right angled at R, in which $PQ = 29$ units, $QR = 21$ units and $\angle PQR = \theta$, then find the values of

- (i) $\cos^2 \theta + \sin^2 \theta$ and (ii) $\cos^2 \theta - \sin^2 \theta$



Solution : In ΔPQR , we have

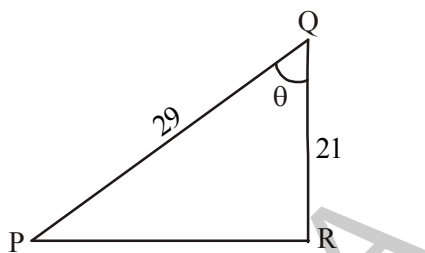
$$\begin{aligned} PR &= \sqrt{PQ^2 - QR^2} = \sqrt{(29)^2 - (21)^2} \\ &= \sqrt{400} = 20 \text{ units} \quad (\text{why?}) \end{aligned}$$

$$\sin \theta = \frac{PR}{PQ} = \frac{20}{29}$$

$$\cos \theta = \frac{QR}{PQ} = \frac{21}{29}$$

$$\text{Now (i) } \cos^2 \theta + \sin^2 \theta = \left(\frac{21}{29}\right)^2 + \left(\frac{20}{29}\right)^2 = \frac{441 + 400}{841} = 1$$

$$\text{(ii) } \cos^2 \theta - \sin^2 \theta = \left(\frac{21}{29}\right)^2 - \left(\frac{20}{29}\right)^2 = \frac{41}{841}$$



Exercise - 11.1

- In right angled triangle ABC, 8 cm, 15 cm and 17 cm are the lengths of AB, BC and CA respectively. Then, find $\sin A$, $\cos A$ and $\tan A$.
- The sides of a right angled triangle PQR are $PQ = 7$ cm, $PR = 25$ cm and $\angle Q = 90^\circ$ respectively. Then find, $\tan P - \tan R$.
- In a right angled triangle ABC with right angle at B, in which $a = 24$ units, $b = 25$ units and $\angle BAC = \theta$. Then, find $\cos \theta$ and $\tan \theta$.
- If $\cos A = \frac{12}{13}$, then find $\sin A$ and $\tan A$ ($\angle A < 90^\circ$).
- If $3 \tan A = 4$, then find $\sin A$ and $\cos A$.
- In ΔABC and ΔXYZ , if $\angle A$ and $\angle X$ are acute angles such that $\cos A = \cos X$ then show that $\angle A = \angle X$.
- Given $\cot \theta = \frac{7}{8}$, then evaluate (i) $\frac{(1 + \sin \theta)(1 - \sin \theta)}{(1 + \cos \theta)(1 - \cos \theta)}$ (ii) $\frac{(1 + \sin \theta)}{\cos \theta}$
- In a right angled triangle ABC, right angle is at B. If $\tan A = \sqrt{3}$, then find the value of
 (i) $\sin A \cos C + \cos A \sin C$ (ii) $\cos A \cos C - \sin A \sin C$



11.3 Trigonometric Ratios

We already know about isosceles right angled triangle and right angled triangle with angles 30° , 60° and 90° .

Can we find $\sin 30^\circ$ or $\tan 60^\circ$ or $\cos 45^\circ$ etc. with the help of these triangles?

Does $\sin 0^\circ$ or $\cos 0^\circ$ exist?

11.3.1 Trigonometric Ratios of 45°

In isosceles right angled triangle ABC right angled at B

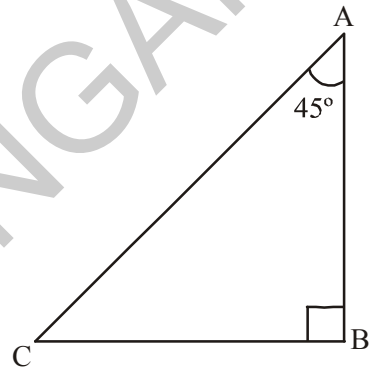
$\angle A = \angle C = 45^\circ$ (why ?) and $BC = AB$ (why ?)

Let's assume the length of $BC = AB = a$

Then, $AC^2 = AB^2 + BC^2$ (by Pythagoras theorem)

$$= a^2 + a^2 = 2a^2,$$

Therefore, $AC = a\sqrt{2}$



Using the definitions of trigonometric ratios,

$$\sin 45^\circ = \frac{\text{Length of the opposite side to angle } 45^\circ}{\text{Length of hypotenuse}} = \frac{BC}{AC} = \frac{a}{a\sqrt{2}} = \frac{1}{\sqrt{2}}$$

$$\cos 45^\circ = \frac{\text{Length of the adjacent side to angle } 45^\circ}{\text{Length of hypotenuse}} = \frac{AB}{AC} = \frac{a}{a\sqrt{2}} = \frac{1}{\sqrt{2}}$$

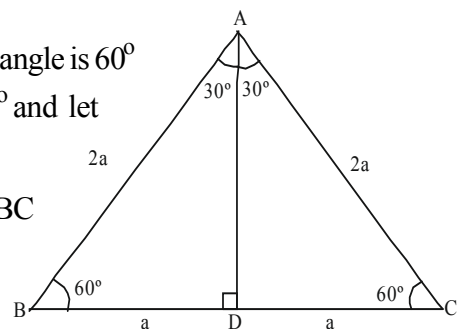
$$\tan 45^\circ = \frac{\text{Length of the opposite side to angle } 45^\circ}{\text{Length of the adjacent side to angle } 45^\circ} = \frac{BC}{AB} = \frac{a}{a} = 1$$

Similarly, you can determine the values of $\operatorname{cosec} 45^\circ$, $\sec 45^\circ$ and $\cot 45^\circ$.

11.3.2 Trigonometric Ratios of 30° and 60°

Consider an equilateral triangle ABC. Since each angle is 60° in an equilateral triangle, we have $\angle A = \angle B = \angle C = 60^\circ$ and let $AB = BC = CA = 2a$ units.

Draw the perpendicular line AD from vertex A to BC as shown in the figure.



Perpendicular \overline{AD} acts also as “angle bisector of angle A” and “bisector of the side \overline{BC} ” in the equilateral triangle $\triangle ABC$.

$$\therefore \angle BAD = \angle DAC = 30^\circ .$$

Since point D divides the side BC in two equal parts,

$$BD = \frac{1}{2} BC = \frac{2a}{2} = a \text{ units.}$$

Consider, right angled triangle $\triangle ABD$, in the above given figure.

We have $AB = 2a$ and $BD = a$

Then, $AD^2 = AB^2 - BD^2$ (by Pythagoras theorem)

$$= (2a)^2 - (a)^2 = 3a^2 .$$

$$\therefore AD = a\sqrt{3}$$

From definitions of trigonometric ratios,

$$\sin 60^\circ = \frac{AD}{AB} = \frac{a\sqrt{3}}{2a} = \frac{\sqrt{3}}{2}$$

$$\cos 60^\circ = \frac{BD}{AB} = \frac{a}{2a} = \frac{1}{2}$$

$$\tan 60^\circ = \sqrt{3} \quad (\text{how?})$$

Similarly, you can also determine $\operatorname{cosec} 60^\circ$, $\sec 60^\circ$ and $\cot 60^\circ$.



Do This

Find the values of $\operatorname{cosec} 60^\circ$, $\sec 60^\circ$ and $\cot 60^\circ$.



Try This

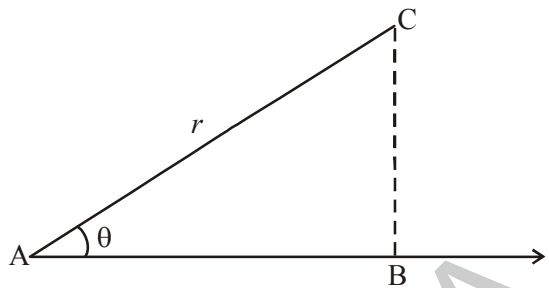
Find the values of $\sin 30^\circ$, $\cos 30^\circ$, $\tan 30^\circ$, $\operatorname{cosec} 30^\circ$, $\sec 30^\circ$ and $\cot 30^\circ$.

11.3.3 Trigonometric Ratios of 0° and 90°

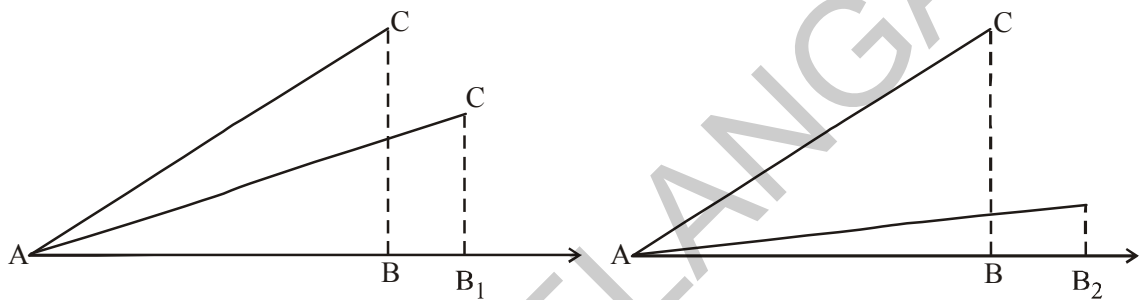
Till now, we have discussed trigonometric ratios of 30° , 45° and 60° . Now let us determine the trigonometric ratios of angles 0° and 90° .



Suppose a segment AC of length r is making an acute angle with ray AB. Height of C from B is BC. When AC leans more on AB so that the angle made by it decreases, then what happens to the lengths of BC and AB?



As the angle A decreases, the height of C from AB ray decreases and foot B is shifted from B to B_1 and B_2 and gradually when the angle becomes zero, height (i.e. opposite side of the angle) will also become zero (0) and adjacent side would be equal to AC i.e. length equal to r .



Step (i)

Step (ii)

Let us look at the trigonometric ratios

$$\sin A = \frac{BC}{AC} \text{ and } \cos A = \frac{AB}{AC}$$

If $A = 0^\circ$ then $BC = 0$ and $AC = AB = r$.

$$\text{Thus, } \sin 0^\circ = \frac{0}{r} = 0 \text{ and } \cos 0^\circ = \frac{r}{r} = 1.$$

$$\text{We know that } \tan A = \frac{\sin A}{\cos A}$$

$$\text{So, } \tan 0^\circ = \frac{\sin 0^\circ}{\cos 0^\circ} = \frac{0}{1} = 0$$



Think and Discuss

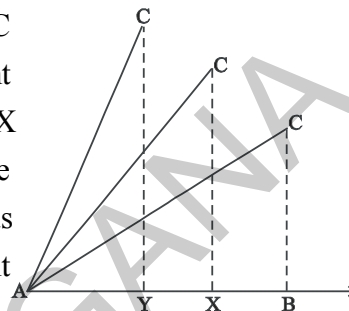
Discuss with your friends about the following conditions:

1. What can you say about $\operatorname{cosec} 0^\circ = \frac{1}{\sin 0^\circ}$? Is it defined? Why?



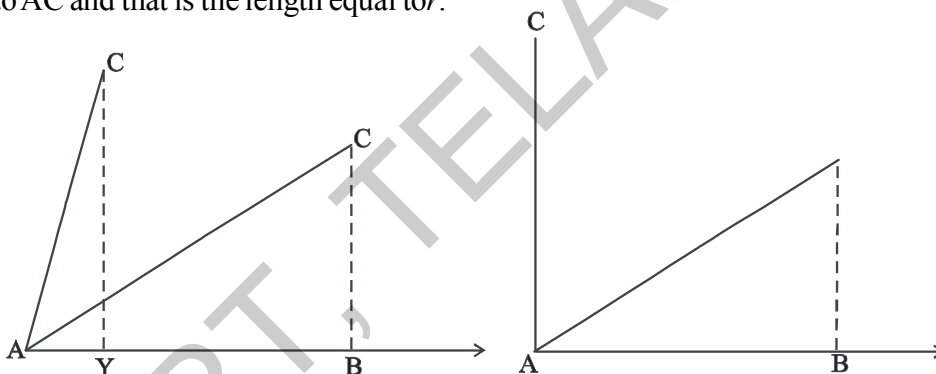
2. What can you say about $\cot 0^\circ = \frac{1}{\tan 0^\circ}$? Is it defined? Why?
3. $\sec 0^\circ = 1$. Why?

Now, let us see what happens when angle made by AC with ray AB increases. When angle A is increased, height of point C increases and the foot of the perpendicular shifts from B to X and then to Y and so on. In other words, we can say that the height BC increases gradually, If the angle at A gets continuous increment. At one stage the angle reaches 90° . At that time, point B reaches A and AC equal to BC.



Step (i)

So, when the angle becomes 90° , base (i.e. adjacent side of the angle) would become zero (0), the height of C from AB ray increases and it would be equal to AC and that is the length equal to r .



Step (ii)

Step (iii)

Now let us see trigonometric ratios

$$\sin A = \frac{BC}{AC} \text{ and } \cos A = \frac{AB}{AC}.$$

If $A = 90^\circ$ then $AB = 0$ and $AC = BC = r$.

$$\text{Then, } \sin 90^\circ = \frac{r}{r} = 1 \text{ and } \cos 90^\circ = \frac{0}{r} = 0.$$



Try This

Find the values for $\tan 90^\circ$, $\operatorname{cosec} 90^\circ$, $\sec 90^\circ$ and $\cot 90^\circ$.



Now, let us observe the values of trigonometric ratios of all the above discussed angles in the form of a table.

Table 11.1

$\angle A$	0°	30°	45°	60°	90°
$\sin A$	0	$\frac{1}{2}$	$\frac{1}{\sqrt{2}}$	$\frac{\sqrt{3}}{2}$	1
$\cos A$	1	$\frac{\sqrt{3}}{2}$	$\frac{1}{\sqrt{2}}$	$\frac{1}{2}$	0
$\tan A$	0	$\frac{1}{\sqrt{3}}$	1	$\sqrt{3}$	not defined
$\cot A$	not defined	$\sqrt{3}$	1	$\frac{1}{\sqrt{3}}$	0
$\sec A$	1	$\frac{2}{\sqrt{3}}$	$\sqrt{2}$	2	not defined
$\operatorname{cosec} A$	not defined	2	$\sqrt{2}$	$\frac{2}{\sqrt{3}}$	1



Think and Discuss

What can you say about the values of $\sin A$ and $\cos A$, as the value of angle A increases from 0° to 90° ? (Observe the above table)

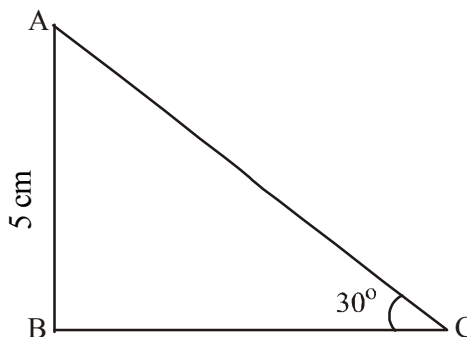
If $A \geq B$, then $\sin A \geq \sin B$. Is it true?

If $A \geq B$, then $\cos A \geq \cos B$. Is it true? Discuss.

Example-4. In $\triangle ABC$, right angle is at B , $AB = 5$ cm and $\angle ACB = 30^\circ$. Determine the lengths of the sides BC and AC .

Solution : Given $AB = 5$ cm and $\angle ACB = 30^\circ$. To find the length of side BC , we will choose the trigonometric ratio involving BC and the given side AB . Since, BC is the side adjacent to angle C and AB is the side opposite to angle C .

$$\text{Therefore, } \frac{AB}{BC} = \tan C$$



$$\text{i.e. } \frac{5}{BC} = \tan 30^\circ = \frac{1}{\sqrt{3}}$$

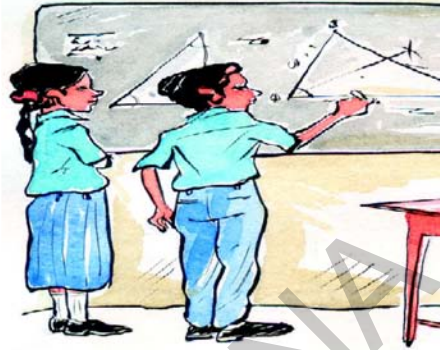
After cross multiplication, $BC = 5\sqrt{3}$ cm

Now, by using the trigonometric ratios in $\triangle ABC$

$$\sin 30^\circ = \frac{AB}{AC}$$

$$\frac{1}{2} = \frac{5}{AC} \quad (\because \sin 30^\circ = \frac{1}{2})$$

$$AC = 10 \text{ cm}$$



Example-5. A chord of a circle of radius 6cm is making an angle 60° at the centre. Find the length of the chord.

Solution : Given that the radius of the circle is $OA = OB = 6\text{cm}$ and $\angle AOB = 60^\circ$.

OC is height from 'O' upon AB and it is an angle bisector.

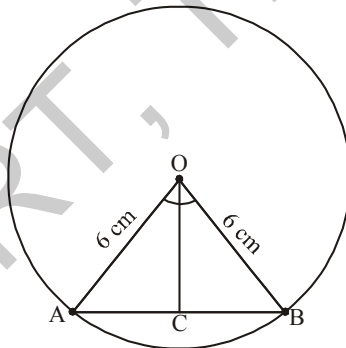
Then, $\angle COB = 30^\circ$.

Consider $\triangle COB$

$$\sin 30^\circ = \frac{BC}{OB}$$

$$\frac{1}{2} = \frac{BC}{6}$$

$$BC = \frac{6}{2} = 3.$$



But, length of the chord $AB = 2BC$

$$= 2 \times 3 = 6 \text{ cm}$$

\therefore length of the chord = 6 cm.

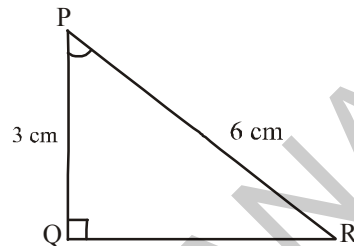
The first use of the idea of 'sine' the way we use it today was given in the book *Aryabhatiyam* by Aryabhata, in 500 C.E. Aryabhata used the word *ardha-jya* for the half-chord, which was shortened to *jya* or *jiva* in due course. When the *Aryabhatiyam* was translated into Arabic, the word *jiva* was retained as it is. The word *jiva* was translated into *sinus*, which means curve, when the Arabic version was translated into Latin. Soon the word *sinus*, also used as *sine*, became common in mathematical texts throughout Europe. An English Professor of astronomy Edmund Gunter (1581–1626), first used the abbreviated notation 'sin'.



Example-6. In ΔPQR , right angle is at Q, $PQ = 3$ cm and $PR = 6$ cm. Determine $\angle QPR$ and $\angle PRQ$.

Solution : Given $PQ = 3$ cm and $PR = 6$ cm

$$\begin{aligned} \therefore \frac{PQ}{PR} &= \sin R \\ \text{or } \sin R &= \frac{3}{6} = \frac{1}{2} = \sin 30^\circ \\ \text{So, } \angle PRQ &= 30^\circ \\ \text{and therefore, } \angle QPR &= 60^\circ \text{ (why?)} \end{aligned}$$



Think and Discuss

If one of the sides and any other part (either an acute angle or any side) of a right angled triangle is known, the remaining sides and angles of the triangle can be determined. Do you agree? Explain with an example.

Example-7. If $\sin(A-B) = \frac{1}{2}$, $\cos(A+B) = \frac{1}{2}$, where $0^\circ < A+B \leq 90^\circ$ and $A > B$, find A and B.

Solution : Since, $\sin(A-B) = \frac{1}{2}$, therefore, $A-B = 30^\circ$ (why?)

Also, since $\cos(A+B) = \frac{1}{2}$, therefore, $A+B = 60^\circ$ (why?)

Solving the above equations, we get : $A = 45^\circ$ and $B = 15^\circ$. (How?)



Exercise - 11.2

1. Evaluate the following.

(i) $\sin 45^\circ + \cos 45^\circ$

(ii) $\frac{\cos 45^\circ}{\sec 30^\circ + \operatorname{cosec} 60^\circ}$

(iii) $\frac{\sin 30^\circ + \tan 45^\circ - \operatorname{cosec} 60^\circ}{\cot 45^\circ + \cos 60^\circ - \sec 30^\circ}$

(iv) $2 \tan^2 45^\circ + \cos^2 30^\circ - \sin^2 60^\circ$

(v) $\frac{\sec^2 60^\circ - \tan^2 60^\circ}{\sin^2 30^\circ + \cos^2 30^\circ}$

2. Choose the right option and justify your choice-

(i) $\frac{2 \tan 30^\circ}{1 + \tan^2 45^\circ} =$

(a) $\sin 60^\circ$

(b) $\cos 60^\circ$

(c) $\tan 30^\circ$

(d) $\sin 30^\circ$



$$(ii) \frac{1 - \tan^2 45^\circ}{1 + \tan^2 45^\circ} =$$

- (a) $\tan 90^\circ$ (b) 1 (c) $\sin 45^\circ$ (d) 0

$$(iii) \frac{2 \tan 30^\circ}{1 - \tan^2 30^\circ} =$$

- (a) $\cos 60^\circ$ (b) $\sin 60^\circ$ (c) $\tan 60^\circ$ (d) $\sin 30^\circ$

- Evaluate $\sin 60^\circ \cos 30^\circ + \sin 30^\circ \cos 60^\circ$. What is the value of $\sin(60^\circ + 30^\circ)$. What can you conclude?
- Is it right to say that $\cos(60^\circ + 30^\circ) = \cos 60^\circ \cos 30^\circ - \sin 60^\circ \sin 30^\circ$.
- In right angled triangle ΔPQR , right angle is at Q, $PQ = 6\text{cm}$ and $\angle RPQ = 60^\circ$. Determine the lengths of QR and PR.
- In ΔXYZ , right angle is at Y, $YZ = x$, and $XZ = 2x$. Then, determine $\angle YXZ$ and $\angle YZX$.
- Is it right to say that $\sin(A + B) = \sin A + \sin B$? Justify your answer.



Think and Discuss

Substitute $\theta = 0^\circ, 30^\circ, 45^\circ, 60^\circ$ and 90° in the equation $\frac{\cos \theta}{1 - \sin \theta} + \frac{\cos \theta}{1 + \sin \theta} = 4$

For which value of θ the above equation is defined or not defined?

11.4 Trigonometric Ratios of Complementary angles

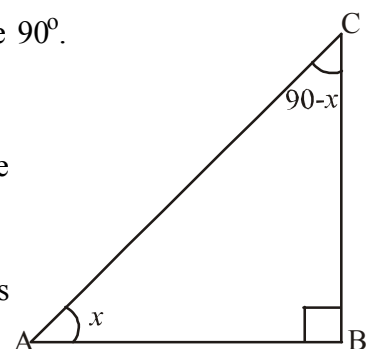
We already know that two angles are said to be complementary, if their sum is equal to 90° . Consider a right angled triangle ABC with right angle at B. Are there any complementary angles in this triangle?

Since, angle B is 90° , sum of other two angles must be 90° .

(why?)

$\therefore \angle A + \angle C = 90^\circ$. Hence $\angle A$ and $\angle C$ are complementary angles.

Let us assume that $\angle A = x$, then for angle x , BC is opposite side and AB is adjacent side.



$$\sin x = \frac{BC}{AC} \quad \cos x = \frac{AB}{AC} \quad \tan x = \frac{BC}{AB}$$

$$\operatorname{cosec} x = \frac{AC}{BC} \quad \sec x = \frac{AC}{AB} \quad \cot x = \frac{AB}{BC}$$

If $\angle A + \angle C = 90^\circ$, then we have $\angle C = 90^\circ - \angle A$

Since, $\angle A = x$, we have $\angle C = 90^\circ - x$

$\angle C$ or $(90^\circ - x)$, AB is opposite side and BC is adjacent side.

$$\sin(90^\circ - x) = \frac{AB}{AC} \quad \cos(90^\circ - x) = \frac{BC}{AC} \quad \tan(90^\circ - x) = \frac{AB}{BC}$$

$$\operatorname{Cosec}(90^\circ - x) = \frac{AC}{AB} \quad \sec(90^\circ - x) = \frac{AC}{BC} \quad \cot(90^\circ - x) = \frac{BC}{AB}$$

Now, if we compare the ratios of angles x° and $(90^\circ - x)$ from the above values of different trigonometric ratios, we get the following relations:

$$\sin(90^\circ - x) = \frac{AB}{AC} = \cos x \quad \text{and} \quad \cos(90^\circ - x) = \frac{BC}{AC} = \sin x$$

$$\tan(90^\circ - x) = \frac{AB}{BC} = \cot x \quad \text{and} \quad \cot(90^\circ - x) = \frac{BC}{AB} = \tan x$$

$$\operatorname{cosec}(90^\circ - x) = \frac{AC}{AB} = \sec x \quad \text{and} \quad \sec(90^\circ - x) = \frac{AC}{BC} = \operatorname{cosec} x$$



Think and Discuss

Check and discuss the above relations in the case of angles between 0° and 90° , whether they hold for these angles or not?

So, $\sin(90^\circ - A) = \cos A$	$\cos(90^\circ - A) = \sin A$
$\tan(90^\circ - A) = \cot A$	$\cot(90^\circ - A) = \tan A$
$\sec(90^\circ - A) = \operatorname{cosec} A$	$\operatorname{cosec}(90^\circ - A) = \sec A$



Now, let us consider some examples.

Example-8. Evaluate $\frac{\sec 35^\circ}{\operatorname{cosec} 55^\circ}$

Solution : $\operatorname{cosec} A = \sec (90^\circ - A)$
 $\operatorname{cosec} 55^\circ = \operatorname{cosec} (90^\circ - 35^\circ)$
 $\operatorname{cosec} 55^\circ = \sec 35^\circ$

Now $\frac{\sec 35^\circ}{\operatorname{cosec} 55^\circ} = \frac{\sec 35^\circ}{\sec 35^\circ} = 1$



Example-9. If $\cos 7A = \sin(A - 6^\circ)$, where $7A$ is an acute angle, find the value of A .

Solution : Given $\cos 7A = \sin(A - 6^\circ)$... (1)

$$\sin(90 - 7A) = \sin(A - 6^\circ)$$

since, $7A$ is a acute angle $\therefore (90 - 7A)$ & $(A - 6^\circ)$ are acute angles,

$$90^\circ - 7A = A - 6^\circ$$

$$8A = 96^\circ$$

$$A = 12^\circ.$$



Example-10. If $\sin A = \cos B$, then prove that $A + B = 90^\circ$.

Solution : Given that $\sin A = \cos B$... (1)

We know $\cos B = \sin(90^\circ - B)$.

So $\sin A = \sin(90^\circ - B)$

Since A, B are acute angles, $A = 90^\circ - B$

$$\Rightarrow A + B = 90^\circ.$$

Example-11. Express $\sin 81^\circ + \tan 81^\circ$ in terms of trigonometric ratios of angles between 0° and 45° .

Solution : $\sin 81^\circ = \sin(90^\circ - 9^\circ) = \cos 9^\circ$

and $\tan 81^\circ = \tan(90^\circ - 9^\circ) = \cot 9^\circ$

Then, $\sin 81^\circ + \tan 81^\circ = \cos 9^\circ + \cot 9^\circ$



Example-12. If A, B and C are interior angles of triangle ABC, then show that $\sin\left(\frac{B+C}{2}\right) = \cos\frac{A}{2}$

Solution : Given A, B and C are angles of triangle ABC then $A + B + C = 180^\circ$.

On dividing the above equation by 2 on both sides, we get

$$\frac{A}{2} + \frac{B+C}{2} = 90^\circ$$

$$\frac{B+C}{2} = 90^\circ - \frac{A}{2}$$

On taking sin ratio on both sides

$$\sin\left(\frac{B+C}{2}\right) = \sin\left(90^\circ - \frac{A}{2}\right)$$

$$\sin\left(\frac{B+C}{2}\right) = \cos\frac{A}{2} \text{ . Hence proved.}$$



Exercise 11.3

1. Evaluate

(i) $\frac{\tan 36^\circ}{\cot 54^\circ}$ (ii) $\cos 12^\circ - \sin 78^\circ$ (iii) $\operatorname{cosec} 31^\circ - \sec 59^\circ$

(iv) $\sin 15^\circ \sec 75^\circ$ (v) $\tan 26^\circ \tan 64^\circ$

2. Show that

(i) $\tan 48^\circ \tan 16^\circ \tan 42^\circ \tan 74^\circ = 1$

(ii) $\cos 36^\circ \cos 54^\circ - \sin 36^\circ \sin 54^\circ = 0$.

3. If $\tan 2A = \cot(A - 18^\circ)$, where $2A$ is an acute angle. Find the value of A.

4. If $\tan A = \cot B$ where A and B are acute angles, prove that $A + B = 90^\circ$.

5. If A, B and C are interior angles of a triangle ABC, then show that

$$\tan\left(\frac{A+B}{2}\right) = \cot\frac{C}{2}$$

6. Express $\sin 75^\circ + \cos 65^\circ$ in terms of trigonometric ratios of angles between 0° and 45° .



11.5 Trigonometric identities

We know that an identity is that mathematical equation which is true for all the values of the variables in the equation.

For example $(a + b)^2 = a^2 + b^2 + 2ab$ is an identity.

In the same way, an identity having trigonometric ratios of an angle is called trigonometric identity. It is true for all the values of the angles involved in it. Here, we will derive a trigonometric identities. Consider a right angled triangle $\triangle ABC$ with right angle at B. From Pythagoras theorem

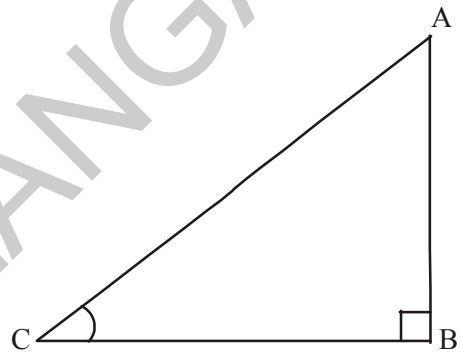
$$AB^2 + BC^2 = AC^2 \quad \dots(1)$$

Dividing each term by AC^2 , we get

$$\Rightarrow \frac{AB^2}{AC^2} + \frac{BC^2}{AC^2} = \frac{AC^2}{AC^2}$$

$$\left[\frac{AB}{AC} \right]^2 + \left[\frac{BC}{AC} \right]^2 = \left[\frac{AC}{AC} \right]^2$$

$$(\cos A)^2 + (\sin A)^2 = 1$$



Here, we generally write $\cos^2 A$ in the place of $(\cos A)^2$

i.e., $(\cos A)^2$ is written as $\cos^2 A$ (Do not write $\cos A^2$)

\therefore above equation is $\cos^2 A + \sin^2 A = 1$

We have given an equation having a variable parameter A (angle) and above equation is true for all the value of A. Hence, the above equation is a trigonometric identity.

\therefore required trigonometric identity is

$$\boxed{\cos^2 A + \sin^2 A = 1.}$$

Let us look at another trigonometric identity

From equation (1) we have

$$AB^2 + BC^2 = AC^2$$

$$\Rightarrow \frac{AB^2}{AB^2} + \frac{BC^2}{AB^2} = \frac{AC^2}{AB^2} \quad (\text{Dividing each term by } AB^2)$$



$$\left(\frac{AB}{AB}\right)^2 + \left(\frac{BC}{AB}\right)^2 = \left(\frac{AC}{AB}\right)^2$$

i.e., $1 + \tan^2 A = \sec^2 A$ ($A \neq 90^\circ$)

Similarly, on dividing (1) by BC^2 , we get $\cot^2 A + 1 = \operatorname{cosec}^2 A$. ($A \neq 0^\circ$)

By using above identities, we can express each trigonometric ratio in terms of another ratio. If we know the value of a ratio, we can find all other ratios by using these identities.



Think and Discuss

Are these identities true only for $0^\circ \leq A \leq 90^\circ$? If not, for which other values of A they are true?

- $\sec^2 A - \tan^2 A = 1$
- $\operatorname{cosec}^2 A - \cot^2 A = 1$



Do This

- (i) If $\sin C = \frac{15}{17}$, then find $\cos C$. (ii) If $\tan x = \frac{5}{12}$, then find $\sec x$.
- (iii) If $\operatorname{cosec} \theta = \frac{25}{7}$, then find $\cot \theta$.



Try This

Evaluate the following and justify your answer.

- (i) $\frac{\sin^2 15^\circ + \sin^2 75^\circ}{\cos^2 36^\circ + \cos^2 54^\circ}$ (ii) $\sin 5^\circ \cos 85^\circ + \cos 5^\circ \sin 85^\circ$
- (iii) $\sec 16^\circ \operatorname{cosec} 74^\circ - \cot 74^\circ \tan 16^\circ$.

Example-13. Show that $\cot \theta + \tan \theta = \sec \theta \operatorname{cosec} \theta$. ($0^\circ < \theta < 90^\circ$)

Solution : LHS = $\cot \theta + \tan \theta$

$$\begin{aligned} &= \frac{\cos \theta}{\sin \theta} + \frac{\sin \theta}{\cos \theta} && \text{(why?)} \\ &= \frac{\cos^2 \theta + \sin^2 \theta}{\sin \theta \cos \theta} \end{aligned}$$



$$= \frac{1}{\sin \theta \cos \theta} \quad (\text{why?})$$

$$= \frac{1}{\sin \theta} \cdot \frac{1}{\cos \theta} = \operatorname{cosec} \theta \sec \theta$$

Example-14. Show that $\tan^2 \theta + \tan^4 \theta = \sec^4 \theta - \sec^2 \theta$ ($\theta \neq 90^\circ$)

Solution : L.H.S. = $\tan^2 \theta + \tan^4 \theta$
 $= \tan^2 \theta (1 + \tan^2 \theta)$
 $= \tan^2 \theta \cdot \sec^2 \theta$ (Why?)
 $= (\sec^2 \theta - 1) \sec^2 \theta$ (Why?)
 $= \sec^4 \theta - \sec^2 \theta = \text{R.H.S}$

Example-15. Prove that $\sqrt{\frac{1+\cos \theta}{1-\cos \theta}} = \operatorname{cosec} \theta + \cot \theta$; ($0^\circ < \theta < 90^\circ$)

Solution : LHS = $\sqrt{\frac{1+\cos \theta}{1-\cos \theta}}$ (multiply numerator and denominator by $\sqrt{(1+\cos \theta)}$)

$$= \sqrt{\frac{1+\cos \theta}{1-\cos \theta} \cdot \frac{1+\cos \theta}{1+\cos \theta}}$$

$$= \sqrt{\frac{(1+\cos \theta)^2}{1-\cos^2 \theta}}$$

$$= \sqrt{\frac{(1+\cos \theta)^2}{\sin^2 \theta}} \quad (\text{Why?})$$

$$= \frac{1+\cos \theta}{\sin \theta}$$

$$= \frac{1}{\sin \theta} + \frac{\cos \theta}{\sin \theta} = \operatorname{cosec} \theta + \cot \theta = \text{R.H.S.}$$



Exercise 11.4

1. Simplify the following:
 - (i) $(1 + \tan \theta + \sec \theta) (1 + \cot \theta - \operatorname{cosec} \theta)$
 - (ii) $(\sin \theta + \cos \theta)^2 + (\sin \theta - \cos \theta)^2$
 - (iii) $(\sec^2 \theta - 1) (\operatorname{cosec}^2 \theta - 1)$



2. Show that $(\operatorname{cosec} \theta - \cot \theta)^2 = \frac{1 - \cos \theta}{1 + \cos \theta}$.
3. Show that $\sqrt{\frac{1 + \sin A}{1 - \sin A}} = \sec A + \tan A$ ($0^\circ < \theta < 90^\circ$).
4. Show that $\frac{1 - \tan^2 A}{\cot^2 A - 1} = \tan^2 A$ ($0^\circ < A < 90^\circ$).
5. Show that $\frac{1}{\cos \theta} - \cos \theta = \tan \theta \cdot \sin \theta$ ($0^\circ < \theta < 90^\circ$).
6. Simplify $\sec A (1 - \sin A) (\sec A + \tan A)$.
7. Prove that $(\sin A + \operatorname{cosec} A)^2 + (\cos A + \sec A)^2 = 7 + \tan^2 A + \cot^2 A$.
8. Simplify $(1 - \cos \theta) (1 + \cos \theta) (1 + \cot^2 \theta)$.
9. If $\sec \theta + \tan \theta = p$, then what is the value of $\sec \theta - \tan \theta$?
10. If $\operatorname{cosec} \theta + \cot \theta = k$, then prove that $\cos \theta = \frac{k^2 - 1}{k^2 + 1}$.



Optional Exercise
[For extensive Learning]

1. Prove that $\frac{\cot \theta - \cos \theta}{\cot \theta + \cos \theta} = \frac{\operatorname{cosec} \theta - 1}{\operatorname{cosec} \theta + 1}$.
2. Prove that $\frac{\sin \theta - \cos \theta + 1}{\sin \theta + \cos \theta - 1} = \frac{1}{\sec \theta - \tan \theta}$ [use the identity $\sec^2 \theta = 1 + \tan^2 \theta$].
3. Prove that $(\operatorname{cosec} A - \sin A) (\sec A - \cos A) = \frac{1}{\tan A + \cot A}$.
4. Prove that $\frac{1 + \sec A}{\sec A} = \frac{\sin^2 A}{1 - \cos A}$.
5. Show that $\left(\frac{1 + \tan^2 A}{1 + \cot^2 A} \right) = \left(\frac{1 + \tan A}{1 - \cot A} \right)^2 = \tan^2 A$.
6. Prove that $\frac{(\sec A - 1)}{(\sec A + 1)} = \frac{(1 - \cos A)}{(1 + \cos A)}$.



Project Work

With the help of trigonometric ratio scale prepared, find the trigonometric ratio values for different angles experimentally and tabulate the data. (Hint: Here use A3 size Graph paper, circular protractor, scale, thread - using them find the values of trigonometric ratios values for different angles.)



What We Have Discussed



1. In a right angled triangle ABC, with right angle at B,

$$\sin A = \frac{\text{Side opposite to angle } A}{\text{Hypotenuse}}, \quad \cos A = \frac{\text{Side adjacent to angle } A}{\text{Hypotenuse}}$$

2. $\operatorname{cosec} A = \frac{1}{\sin A}$; $\sec A = \frac{1}{\cos A}$; $\tan A = \frac{\sin A}{\cos A}$; $\cot A = \frac{1}{\tan A}$

3. If one of the trigonometric ratios of an acute angle is known, the remaining trigonometric ratios of the angle can be determined.

4. The values of the trigonometric ratios for angle 0° , 30° , 45° , 60° and 90° .

5. The value of $\sin A$ and $\cos A$ never exceeds 1, whereas the value of $\sec A$ ($A \neq 90^\circ$) and $\operatorname{cosec} A$ ($A \neq 0^\circ$) is always greater than or equal to 1.

6. $\sin(90^\circ - A) = \cos A$, $\cos(90^\circ - A) = \sin A$

$$\tan(90^\circ - A) = \cot A, \quad \cot(90^\circ - A) = \tan A$$

$$\sec A(90^\circ - A) = \operatorname{cosec} A, \quad \operatorname{cosec}(90^\circ - A) = \sec A$$

7. $\sin^2 A + \cos^2 A = 1$

$$\sec^2 A - \tan^2 A = 1 \quad (0^\circ \leq A < 90^\circ)$$

$$\operatorname{cosec}^2 A - \cot^2 A = 1 \quad \text{for } (0^\circ < A \leq 90^\circ)$$





12.1 Introduction

You have studied in social studies that the highest mountain peak in the world is Mount Everest and its height is 8848 meters. Kuntala waterfall in Adilabad district is the highest natural waterfall in Telangana. Its height is 147 feet.

Is it possible to measure these heights by using measuring tape?

How were these heights measured?

Can you measure the height of your school building or the tallest tree in or around your school?

Let us understand through some examples.

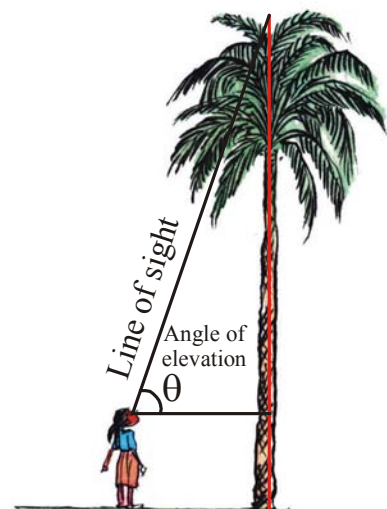


Vijaya wants to find the height of a palm tree. She tries to locate the top most point of the tree. She also imagines a line joining the top most point and her eye. This line is called “line of sight”. She also imagines a horizontal line, from her eye to the tree.

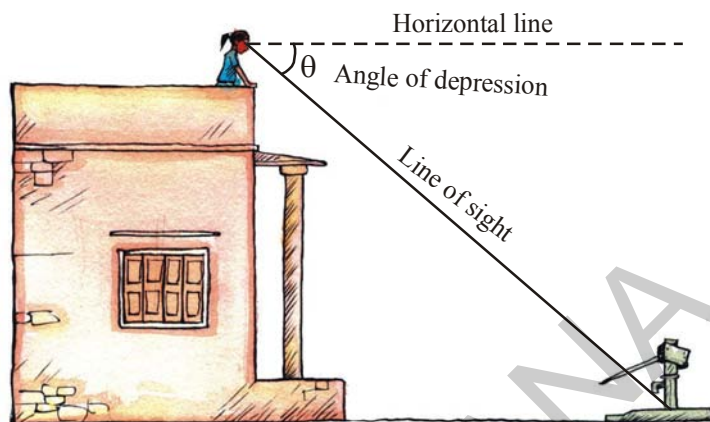
Here, “the line of sight”, “horizontal line” and “the tree” form a right angle triangle.

To find the height of the tree, she needs to find a side and an angle in this triangle.

“The line of sight is above the horizontal line and angle between the line of sight and the horizontal line is called **angle of elevation**”.



Suppose, you are standing on the top of your school building and you want to find the distance of borewell from the building on which you are standing. For that, you have to observe the base of the borewell.



Then, the line of sight from your eye to the base of borewell is below the horizontal line from your eye.

Here, “the angle between the line of sight and horizontal line is called **angle of depression.**”

Trigonometry has been used by surveyors for centuries. They use Theodolites to measure angles of elevation or depression in the process of survey. In nineteenth century, two large Theodolites were built by British India for the surveying project “great trigonometric survey”. During the survey in 1852, the highest mountain peak in the world was discovered in the Himalayas. From the distance of 160 km, the peak was observed from six different stations and the height of the peak was calculated. In 1856, this peak was named after Sir George Everest, who had commissioned and first used the giant Theodolites. Those theodolites are kept in the museum of the Survey of India in Dehradun for display.

12.2 Drawing Figures to Solve Problems

When we want to solve the problems of heights and distances, we should consider the following:

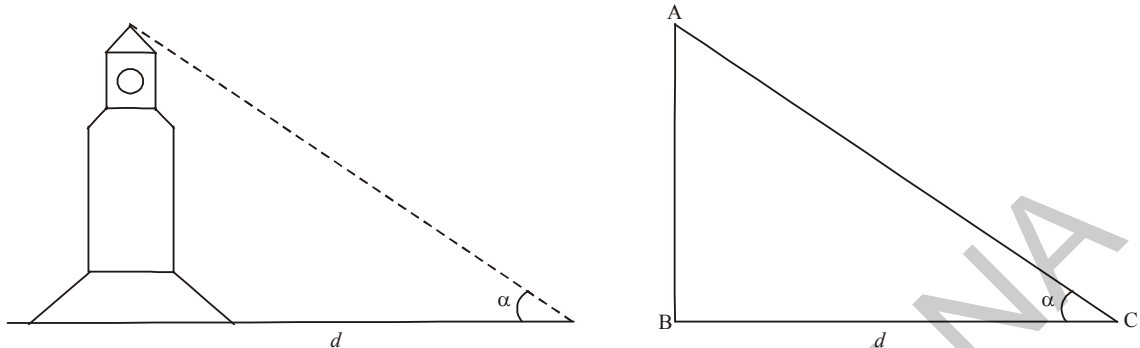
- (i) All the objects such as towers, trees, buildings, ships, mountains etc. shall be considered as linear for mathematical convenience.
- (ii) The angle of elevation or angle of depression is considered with reference to the horizontal line.
- (iii) The height of the observer is neglected, if it is not given in the problem.

When we try to find heights and distances at an angle of elevation or depression, we need to visualise geometrically. To find heights and distances, we need to draw figures and with the help of these figures we can solve the problems. Let us see some examples.

Example-1. The top of a clock tower is observed at angle of elevation of α° and the foot of the tower is at the distance of d meters from the observer. Draw the diagram for this data.

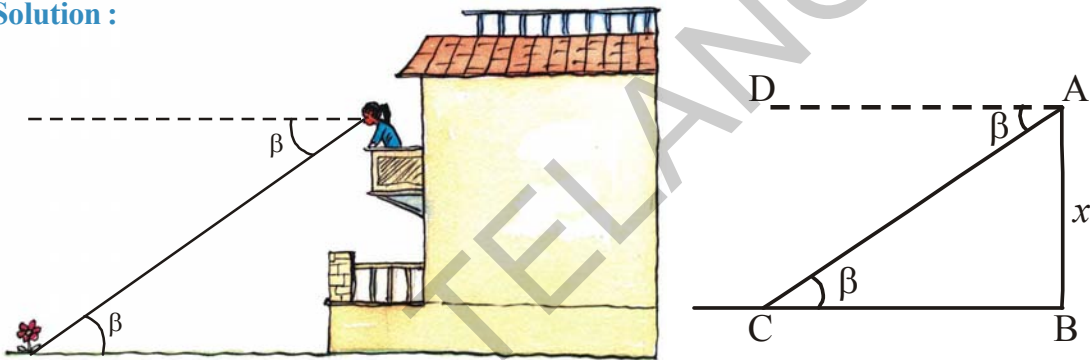


Solution : The diagrams are as shown below :



Example-2. Rinky observes a flower on the ground from the balcony of the first floor of a building at an angle of depression β^0 . The height of the first floor of the building is x meters. Draw the diagram for this data.

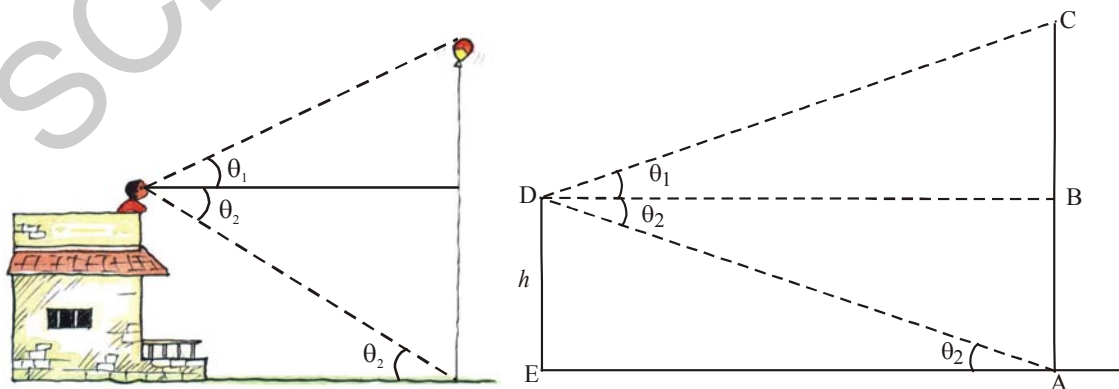
Solution :



Here $\angle DAC = \angle BCA = \beta$ (why?)

Example-3. A large balloon has been tied with a rope and it is floating in the air. A person has observed the balloon from the top of a building at angle of elevation of θ_1 and foot of the rope at an angle of depression of θ_2 . The height of the building is h feet. Draw the diagram for this data.

Solution : We can see that $\angle ADB = \angle DAE$. (Why?)





Do This

- Draw diagram for the following situations :
 - A person is flying a kite at an angle of elevation α° and the length of thread from his hand to kite is ' l '.
 - A person observes two banks of a river at angles of depression θ_1 and θ_2 ($\theta_1 < \theta_2$) from the top of a tree of height h which is at a side of the river. The width of the river is ' d '.



Think and Discuss

- You are observing top of your school building at an angle of elevation α from a point which is at d meter distance from foot of the building.
Which trigonometric ratio would you like to consider to find the height of the building?
- A ladder of length x meter is leaning against a wall making angle θ with the ground.
Which trigonometric ratio would you like to consider to find the height of the point on the wall at which the ladder is touching?

Till now, we have discussed how to draw diagrams as per the situations given. Now, we shall discuss how to find heights and distances.

Example-4. A boy observed the top of an electric pole at an angle of elevation of 60° when the observation point is 8 meters away from the foot of the pole. Find the height of the pole.

Solution : From the figure, in triangle ΔOAB

$$OB = 8 \text{ meters and}$$

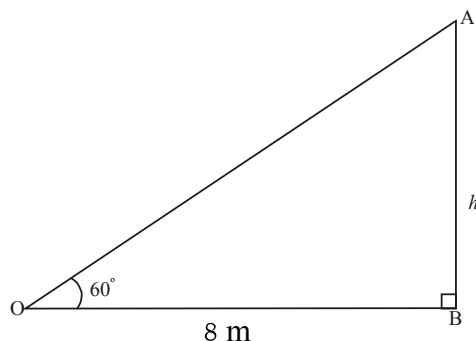
$$\angle AOB = 60^\circ.$$

$$\text{Let height of the pole} = AB = h \text{ meters}$$

(we know the adjacent side and we need to find the opposite side of $\angle AOB$ in the triangle ΔOAB . Hence we need to consider the trigonometric ratio “tangent” to solve the problem).

$$\tan 60^\circ = \frac{AB}{OB}$$

$$\sqrt{3} = \frac{h}{8} \quad h = 8\sqrt{3}m.$$



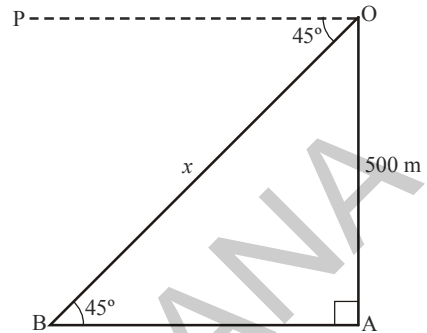
Example-5. From a helicopter, Rajender observes a person standing on the ground at an angle of depression 45° . If the helicopter is flying at a height of 500m from the ground, what is the distance of the person from Rajender?

Solution : From the figure, in triangle $\triangle OAB$

$$OA = 500 \text{ m and}$$

$$\angle POB = \angle ABO = 45^\circ \text{ (why ?)}$$

$OB =$ distance of the person from Rajender $= x$.



(we know the opposite side of $\angle ABO$ and we need to find hypotenuse OB in the triangle OAB . Hence, we need to consider the ratio “sine”.)

$$\sin 45^\circ = \frac{OA}{OB}$$

$$\frac{1}{\sqrt{2}} = \frac{500}{x}$$

$$x = 500\sqrt{2} \text{ m}$$

The distance from the person to Rajendar is $500\sqrt{2} \text{ m}$

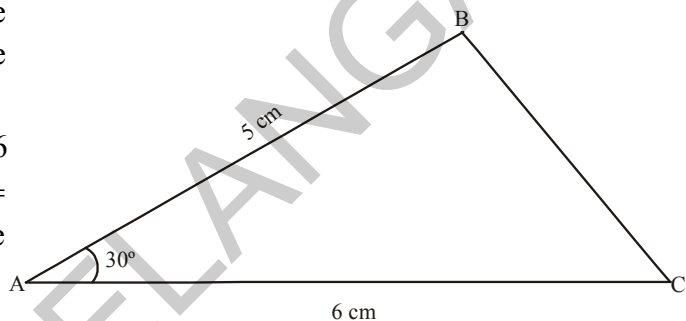


Exercise - 12.1

1. A tower stands vertically on the ground. From a point which is 15 meter away from the foot of the tower, the angle of elevation of the top of the tower is 45° . What is the height of the tower?
2. A tree was broken due to storm and the broken part bends so that the top of the tree touches the ground by making 30° angle with the ground. The distance between the foot of the tree and the top of the tree on the ground is 6m. Find the height of the tree before falling down.
3. A contractor wants to set up a slide for the children to play in the park. He wants to set it up at the height of 2 m and by making an angle of 30° with the ground. What should be the length of the slide?
4. Length of the shadow of a 15 meter high pole is $15\sqrt{3}$ meters at 8 O'clock in the morning. Then, what is the angle of the Sun rays with the ground at the time?
5. You want to setup a pole of height 10 m vertically with the support of three ropes. Each rope has to make an angle 30° with the pole. What should be the length of the rope?



6. Suppose, you are shooting an arrow from the top of a building at an height of 6 m to a target on the ground at an angle of depression of 60° . What is the distance between you and the object?
7. An electrician wants to repair an electric connection on a pole of height 9 m. He needs to reach 1.8 m below the top of the pole to do repair work. What should be the length of the ladder he should use, when it makes an angle of 60° with the ground? What will be the distance between foot of the ladder and foot of the pole?
8. A boat has to cross a river. It crosses the river by making an angle of 60° with the bank of the river due to the stream of the river and travels a distance of 600m to reach the another side of the river. What is the width of the river?
9. An observer of height 1.8 m is 13.2 m away from a palm tree. The angle of elevation of the top of the tree from his eye is 45° . What is the height of the palm tree?
10. In the adjacent figure, $AC = 6$ cm, $AB = 5$ cm and $\angle BAC = 30^\circ$. Find the area of the triangle.



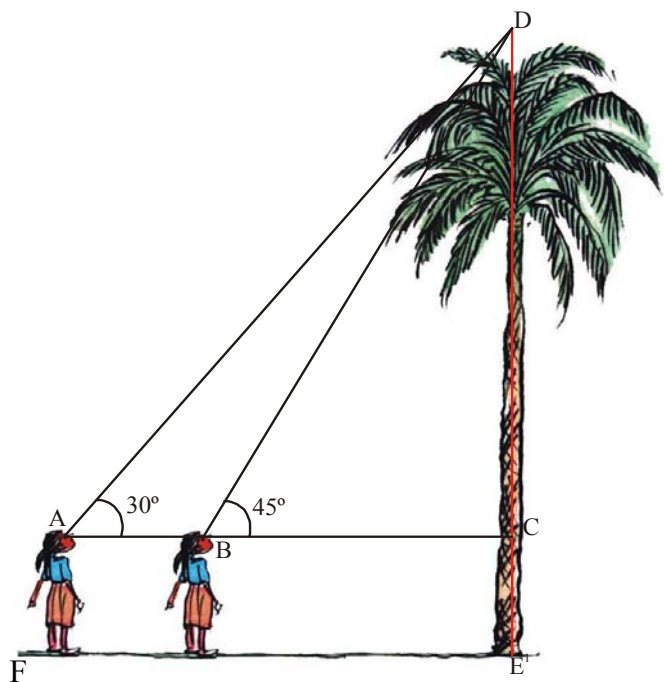
12.3 Problems with Two right-angled Triangles

We have discussed the solution of a one triangle problem. What will be the solution if there are two triangles?

Suppose, you are observing a tree from a certain distance. You want to find the height of the tree you are observing the tree from two different points of observation in the same line with the tree.

How can you do this? Suppose you are observing the top of the palm tree at an angle of elevation of 45° . The angle of elevation changes to 30° when you move 11m away from the earlier point.

Let us see how we can find height of the tree.



From figure, we have

$$AB = 11 \text{ m}$$

$$\angle CAD = 30^\circ$$

$$\angle CBD = 45^\circ$$

Let the height of the palm tree $CD = h$ meters
and length of $BC = x$.

$$\text{Then } AC = 11 + x.$$

From triangle BDC ,

$$\tan 45^\circ = \frac{DC}{BC}$$

$$1 = \frac{h}{x} \Rightarrow x = h$$

From triangle ADC ,

$$\tan 30^\circ = \frac{DC}{AC}$$

$$\frac{1}{\sqrt{3}} = \frac{h}{11+x}$$

$$h = \frac{11+x}{\sqrt{3}} = \frac{11+h}{\sqrt{3}} \quad (\text{why?})$$

$$h = \frac{11}{\sqrt{3}} + \frac{h}{\sqrt{3}}$$

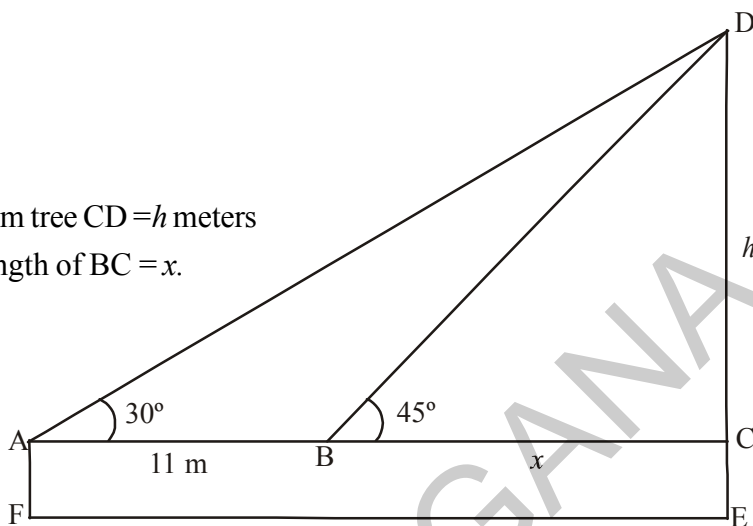
$$h - \frac{h}{\sqrt{3}} = \frac{11}{\sqrt{3}}$$

$$h \frac{(\sqrt{3}-1)}{\sqrt{3}} = \frac{11}{\sqrt{3}}$$

$$h = \frac{11}{(\sqrt{3}-1)} \text{ m.}$$

The height of the palm tree is $\frac{11}{(\sqrt{3}-1)} \text{ m}$

Note : Total height of the palm tree is $CD + CE$ where $CE = AF$, which is the height of the girl.



Example-6. Two men on either side of a temple of 30 meter height observe its top at the angles of elevation 30° and 60° respectively. Find the distance between the two men.

Solution : Height of the temple $BD = 30$ meter.

Angle of elevation of first person $\angle DAB = 30^\circ$

Angle of elevation of second person $\angle BCD = 60^\circ$

Let the distance between the first person and the temple, $AD = x$ and distance between the second person and the temple, $CD = d$

From $\triangle BAD$

$$\tan 30^\circ = \frac{BD}{AD}$$

$$\frac{1}{\sqrt{3}} = \frac{30}{x}$$

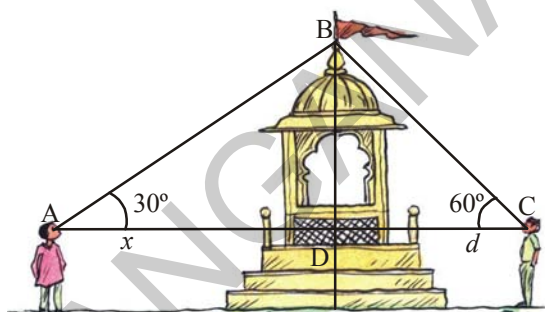
$$x = 30\sqrt{3} \dots\dots\dots (1)$$

From $\triangle BCD$

$$\tan 60^\circ = \frac{BD}{CD}$$

$$\sqrt{3} = \frac{30}{d}$$

$$d = \frac{30}{\sqrt{3}} \dots\dots\dots (2)$$



from (1) and (2) distance between the persons = $BC + BA = x + d$

$$= 30\sqrt{3} + \frac{30}{\sqrt{3}} = \frac{30 \times 4}{\sqrt{3}} = \frac{120}{\sqrt{3}} = 40\sqrt{3} \text{ m}$$

The required distance is $40\sqrt{3} \text{ m}$

Example-7. A straight highway leads to the foot of a tower. Ramaiah standing at the top of the tower observes a car at an angle of depression of 30° . The car is approaching the foot of the tower with a uniform speed. Six seconds later, the angle of depression of the car is found to be 60° . Find the time taken by the car to reach the foot of the tower from this point.

Solution :

Let the distance travelled by the car in 6 seconds = $AB = x$ meters

Heights of the tower $CD = h$ meters

The remaining distance to be travelled by

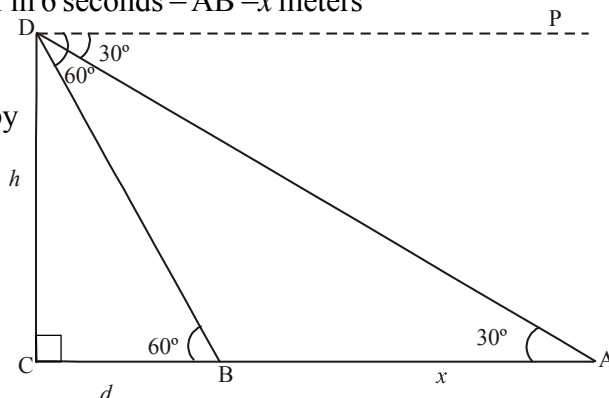
the car $BC = d$ meters

and $AC = AB + BC = (x + d)$ meters

$\angle ADP = \angle DAB = 30^\circ$ (why?)

$\angle BDP = \angle DBC = 60^\circ$ (why?)

From $\triangle BCD$



$$\tan 60^\circ = \frac{CD}{BC}$$

$$\sqrt{3} = \frac{h}{d}$$

$$h = \sqrt{3}d \quad \dots(1)$$

From $\triangle ACD$

$$\tan 30^\circ = \frac{CD}{AC}$$

$$\frac{1}{\sqrt{3}} = \frac{h}{(x+d)}$$

$$h = \frac{(x+d)}{\sqrt{3}} \quad \dots(2)$$

From (1) & (2), we have

$$\frac{x+d}{\sqrt{3}} = \sqrt{3}d$$

$$x+d = 3d$$

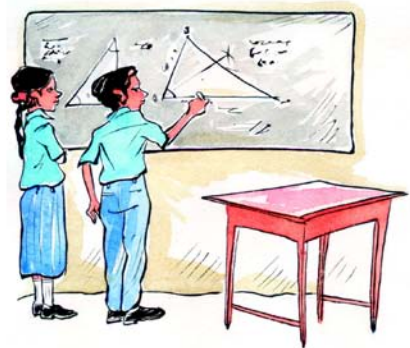
$$x = 2d$$

$$d = \frac{x}{2}$$

Time taken to travel 'x' meters = 6 seconds.

Time taken to travel the distance of 'd' meters

i.e., $\frac{x}{2}$ meters is 3 seconds.



Exercise - 12.2

1. A TV tower stands vertically on the side of a road. From a point on the other side directly opposite to the tower, the angle of elevation of the top of tower is 60° . From another point 10 m away from this point, on the line joining this point to the foot of the tower, the angle of elevation of the top of the tower is 30° . Find the height of the tower and the width of the road.
2. A 1.5 m tall boy is looking at the top of a temple which is 30 meter in height from a point at certain distance. The angle of elevation from his eye to the top of the crown of the temple increases from 30° to 60° as he walks towards the temple. Find the distance he walked towards the temple.



3. A statue stands on the top of a 2m tall pedestal. From a point on the ground, the angle of elevation of the top of the statue is 60° and from the same point, the angle of elevation of the top of the pedestal is 45° . Find the height of the statue.
4. From the top of a building, the angle of elevation of the top of a cell tower is 60° and the angle of depression to its foot is 45° . If distance of the building from the tower is 7m, then find the height of the tower.
5. A wire of length 18 m had been tied with electric pole at an angle of elevation 30° with the ground. Because it was covering a long distance, it was cut and tied at an angle of elevation 60° with the ground. How much length of the wire was cut?
6. The angle of elevation of the top of a building from the foot of the tower is 30° and the angle of elevation of the top of the tower from the foot of the building is 60° . If the tower is 30 m high, find the height of the building.
7. Two poles of equal heights are standing opposite to each other on either side of the road, which is 120 feet wide. From a point between them on the road, the angles of elevation of the top of the poles are 60° and 30° respectively. Find the height of the poles and the distances of the point from the poles.
8. The angles of elevation of the top of a tower from two points at a distance of 4 m and 9 m from the base of the tower and in the same straight line with it are complementary. Find the height of the tower.
9. The angle of elevation of a jet plane from a point A on the ground is 60° . After a flight of 15 seconds, the angle of elevation changes to 30° . If the jet plane is flying at a constant height of $1500\sqrt{3}$ meter, find the speed of the jet plane. ($\sqrt{3} = 1.732$)
10. The angle of elevation of the top of a tower from the foot of a building is 30° and the angle of elevation of the top of the building from the foot of the tower is 60° . What is the ratio of heights of tower and building?



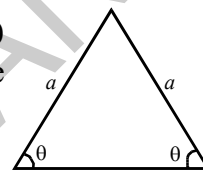
Optional Exercise

[For extensive learning]

1. A 1.2 m tall girl spots a balloon moving with the wind in a horizontal line at a height of 88.2 m from the ground. The angle of elevation of the balloon from the eyes of the girl at an instant is 60° . After some time, the angle of elevation reduces to 30° . Find the distance travelled by the balloon during that interval.



- The angles of elevation of the top of a lighthouse from 3 boats A, B and C in a straight line of same side of the light house are $a, 2a, 3a$ respectively. If the distance between the boats A and B and the boats B and C are x and y respectively find the height of the light house?
- Inner part of a cupboard is in the cuboidal shape with its length, breadth and height in the ratio $1 : \sqrt{2} : 1$. What is the angle made by the longest stick which can be inserted in the cupboard with its base inside.
- An iron spherical ball of volume 232848 cm^3 has been melted and converted into a solid cone with the vertical angle of 120° . What are its height and diameter of the base of the cone?
- Show that the area of an Isosceles triangle is $A = a^2 \sin \theta \cos \theta$ where a is the length of one of the two equal sides and θ is the measure of one of two equal angles
- A right circular cylindrical tower with height ' h ' and radius ' r ', stands on the ground. Let ' p ' be a point in the horizontal plane ground and ABC be the semi-circular edge of the top of the tower such that B is the point in it nearest to p . The angles of elevation of the points A and B are 45° and 60° respectively. Show that $\frac{h}{r} = \frac{\sqrt{3}(1 + \sqrt{3})}{2}$.



Suggested Projects

Find the heights and distances

- Preparation and using clinometer - find the height of a tower/ tree/ building their distances from point of observation.



What We Have Discussed

In this chapter, we have studied the following points :

- The line of sight is the line drawn from the eye of an observer to a point on the object being viewed by the observer.
 - The angle of elevation of the object viewed, is the angle formed by the line of sight with the horizontal when it is above the horizontal level, i.e., the case when we raise our head to look at the object.
 - The angle of depression of an object viewed, is the angle formed by the line of sight with the horizontal when it is below the horizontal level, i.e., the case when we lower our head to look at the object.
- The height or length of an object or the distance between two distant objects can be determined with the help of trigonometric ratios.





13.1 Introduction

Kumar and Sudha were talking together while playing a carroms game:

Kumar : Do you think that you would win?

Sudha : There are 50 percent chances for that. I may win.

Kumar : How do you say 50 percent?

Do you think Sudha is right in her statement?

Is her chance of wining 50%? Do you agree with her?

In this chapter, we study about such situations. We also discuss words like ‘probably’, ‘likely’, ‘possibly’, etc. and how to quantify these. In class IX we studied about events that are extremely likely or almost certain and those that are extremely unlikely and hence almost impossible. We also talked about chance, luck and the fact that an event occurs once does not mean that it would happen each time. In this chapter, we try to learn how the likelihood of an event can be quantified.

This quantification into a numerical measure is referred to as finding 'Probability'.

13.1.1 What is Probability

Consider an experiment: A normal coin was tossed 1000 times. Head turned up 455 times and tail turned up 545 times. If we try to find the likelihood of getting heads we may say it is 455 out of 1000 or $\frac{455}{1000}$ or 0.455.

This estimation of probability is based on the results of an actual experiment of tossing a coin 1000 times.

These estimates are called experimental or empirical probabilities. In fact, all experimental probabilities are based on the results of actual experiments and an adequate recording of what happens in each of the events. These probabilities are only 'estimations'. If we perform the same experiment for another 1000 times, we may get slightly different data, giving different probability estimate.



Many persons from different parts of the world have done this kind of experiment and recorded the number of heads that turned up.

For example, the eighteenth century French naturalist Comte de Buffon, tossed a coin 4040 times and got 2048 times heads. The experimental probability of getting a head, in this case, was $\frac{2048}{4040} \approx 0.507$.

J.E. Kerrich, from Britain, recorded 5067 heads in 10000 tosses of a coin. The experimental probability of getting a head, in this case, was $\frac{5067}{10000} = 0.5067$. English Statistician Karl Pearson spent some more time, making 24000 tosses of a coin. He got 12012 times heads, and thus, the experimental probability of a head obtained by him was 0.5005.

Now, suppose we ask, 'What will be the experimental probability of getting a head, if the experiment is carried on up to, say, 10 lakhs times? Or 1 crore times? You would intuitively feel that as the number of tosses increases, the experimental probability of a head (or a tail) may settle down closer and closer to the number 0.5, i.e., $\frac{1}{2}$. This matches the 'theoretical probability' of getting a head (or getting a tail), about which we will learn now. This chapter is an introduction to the theoretical (also called classical) probability of an event.

Now we discuss simple problems based on this concept.

13.2 Probability - A Theoretical Approach

Let us consider the following situation: Suppose a 'fair' coin is tossed at random.

When we speak of a coin, we assume it to be 'fair', that is, it is symmetrical so that there is no reason for it to come down more often on one side than the other. We call this property of the coin as being 'unbiased'. By the phrase 'random toss', we mean that the coin is allowed to fall freely without any bias or interference. These types of experiments are random experiments (Here we dismiss the possibility of its 'landing' on its edge, which may be possible, for example, if it falls on sand). We refer to this by saying that the outcomes, head and tail, are equally likely.

Outcomes in an experiment are "equally likely" when chances of getting them are equal.

For basic understanding of probability, in this chapter, we will assume that all the experiments have equally likely outcomes.





Do This

- Outcomes of which of the following experiments are equally likely?
 - Getting a digit 1, 2, 3, 4, 5 or 6 when a dice is rolled.
 - Selecting a different colour ball from a bag of 5 red balls, 4 blue balls and 1 black ball.
 - Winning in a game of carrom.
 - Units place of a two digit number selected may be 0, 1, 2, 3, 4, 5, 6, 7, 8 or 9.
 - Selecting a different colour ball from a bag of 10 red balls, 10 blue balls and 10 black balls.
 - Raining on a particular day of July.
- Are the outcomes of every experiment equally likely?
- Give examples of 5 experiments that have equally likely outcomes and five more examples that do not have equally likely outcomes.



Activity

- Take any coin, toss it 50 times, 100 times and 150 times and count the number of times a head and a tail come up separately. Record your observations in the following table:-

S. No.	Number of experiments	Number of heads	Probability of head	Number of tails	Probability of tails
1.	50				
2.	100				
3.	150				

What do you observe? Obviously, as the number of experiments increases, probability of head or tail reaches 50% or $\frac{1}{2}$. This empirical interpretation of probability can be applied to every event associated with an experiment that can be repeated a large number of times.

Now, we know that the experimental or empirical probability $P(E)$ of an event E is

$$P(E) = \frac{\text{Number of trials in which the event happened}}{\text{Total number of trials}}$$

“The assumption of equally likely outcomes” (which is valid in many experiments, as in two of the examples seen, of a coin and of a dice) is one of the assumption that leads us to the following definition of probability of an event.

Probability and Modelling

The requirement of repeating an experiment has some limitations, as it may be very expensive or unfeasible in many situations. Of course, it worked well in the experiments of



tossing the coin or throwing a dice. But, how about repeating the experiment of launching a satellite in order to compute the empirical probability of its failure during launching, or the repetition of the phenomenon of an earthquake to compute the empirical probability of a multi-storeyed building getting destroyed in an earthquake? For finding these probabilities we calculate models of behaviour and use them to estimate behaviour and likely outcomes. Such models are complex and are validated by predictions and outcomes. Forecast of weather, result of an election, population demography, earthquakes, crop production etc. are all based on such models and their predictions.

The theoretical probability (also called classical probability) of an event T, written as P(T), is defined as

$$P(T) = \frac{\text{Number of outcomes favourable to T}}{\text{Number of all possible outcomes of the experiment}}$$

where we assume that the outcomes of the experiment are equally likely. We usually simply refer to theoretical probability as Probability.

The definition of probability was given by Pierre Simon Laplace in 1795.

Probability theory had its origin in the 16th century when an Italian physician and mathematician J. Cardan wrote the first book on the subject, The Book on Games of Chance. James Bernoulli (1654 -1705), A. De Moivre (1667-1754), and Pierre Simon Laplace are among those who made significant contributions to this field. In recent years, probability has been used extensively in many areas such as biology, economics, genetics, physics, sociology etc.



Pierre Simon Laplace
(1749 – 1827)

13.3 Mutually Exclusive Events

If a coin is tossed, we get a head or a tail, but not both. Similarly, if we select a student of a high school that he/ she may belong to one of either 6, 7, 8, 9 or 10 classes, but not to any two or more classes. In both these examples, occurrence of an event prevents the occurrence of other events. Such events are called **mutually exclusive events**.

Two or more events of an experiment, where occurrence of an event prevents occurrences of all other events, are called **Mutually Exclusive Events**. We will discuss this in more detail later in the chapter.



13.4.1 Finding Probability

How do we find the probability of events that are equally likely? We consider the tossing of a coin as an event associated with experiments where the equally likely assumption holds. In order to proceed, we recall that there are two possible outcomes each time. This set of outcomes is called the **sample space**. We can say that the “**sample space**” of one toss is $\{H, T\}$. For the experiment of drawing out a ball from a bag containing red, blue, yellow and white ball, the sample space is $\{R, B, Y, W\}$. What is the **sample space** when a dice is thrown?



Do This

Think of 5 situations with equally likely events and find the sample space.

Let us now try to find the probability of equally likely events that are mutually exclusive.

Example-1. Find the probability of getting a head when a coin is tossed once. Also find the probability of getting a tail.

Solution : In the experiment of tossing a coin once, the number of possible outcomes is two - Head (H) and Tail (T). Let E be the event 'getting a head'. The number of outcomes favourable to E, (i.e., of getting a head) is 1. Therefore,

$$P(E) = P(\text{head}) = \frac{\text{Number of outcomes favourable to E}}{\text{Number of all possible outcomes}} = \frac{1}{2}$$

Similarly, if F is the event 'getting a tail', then

$$P(F) = P(\text{tail}) = \frac{1}{2} \text{ (Guess why?)}$$

Example-2. A bag contains a red ball, a blue ball and an yellow ball, all the balls being of the same size. Manasa takes out a ball from the bag without looking into it. What is the probability that she takes a (i) yellow ball? (ii) red ball? (iii) blue ball?

Solution : Manasa takes out a ball from the bag without looking into it. So, it is equally likely that she takes out any one of them.

Let Y be the event 'the ball taken out is yellow', B be the event 'the ball taken out is blue', and R be the event 'the ball taken out is red'.

Now, the number of possible outcomes = 3.

(i) The number of outcomes favourable to the event $Y = 1$.

$$\text{So, } P(Y) = \frac{1}{3}. \text{ Similarly, } P(R) = \frac{1}{3} \text{ and } P(B) = \frac{1}{3}$$



Remarks

1. An event having only one outcome in an experiment is called an elementary event. In Example 1, both the events E and F are elementary events. Similarly, in Example 2, all the three events, Y, B and R are elementary events.

2. In Example 1, we note that : $P(E) + P(F) = 1$
 In Example 2, we note that : $P(Y) + P(R) + P(B) = 1$.

If we find the sum of the probabilities of all the elementary events, we would get the total as 1.

3. In events like a throwing a dice, probability of getting less than 3 and of getting a 3 or more than three are not elementary events of the possible outcomes. In tossing two coins {HH}, {HT}, {TH} and {TT} are elementary events.

Example-3. Suppose we throw a dice once. (i) What is the probability of getting a number greater than 4? (ii) What is the probability of getting a number less than or equal to 4?

Solution : (i) In rolling an unbiased dice

Sample space $S = \{1, 2, 3, 4, 5, 6\}$

No. of outcomes $n(S) = 6$

Favourable outcomes for }
 number greater than 4 } $E = \{5, 6\}$

No. of favourable outcomes $n(E) = 2$

\therefore Probability of event E $P(E) = \frac{2}{6} = \frac{1}{3}$

(ii) Let F be the event 'getting a number less than or equal to 4'.

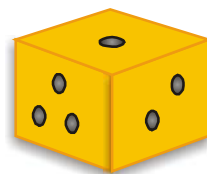
Sample space $S = \{1, 2, 3, 4, 5, 6\}$

No. of outcomes $n(S) = 6$

Favourable outcomes for F $F = \{1, 2, 3, 4\}$

No. of favourable outcomes $n(F) = 4$

\therefore Probability of an event F $P(F) = \frac{4}{6} = \frac{2}{3}$



Note : Are the events E and F in the above example elementary events?

No, they are not elementary events. The event E has 2 outcomes and the event F has 4 outcomes.

13.4.2 Complementary Events and Probability

In the previous section, we read about elementary events. Then in example-3, we calculated probability of events which are not elementary. We saw,

$$P(E) + P(F) = \frac{1}{3} + \frac{2}{3} = 1$$

Here, F is the same as 'not E' because there are only two events.

We denote the event 'not E' by \bar{E} . This is called the **complement** event of event E.

So, $P(E) + P(\text{not } E) = 1$

i.e., $P(E) + P(\bar{E}) = 1$, which gives us $P(\bar{E}) = 1 - P(E)$.

In general, it is true that for an event E, $P(\bar{E}) = 1 - P(E)$



Do This

- (i) Is 'getting a head' complementary to 'getting a tail'? Give reasons.
- (ii) In case of a dice is getting a 1 complementary to events getting 2, 3, 4, 5, 6? Give reasons for your answer.
- (iii) Write of any five pair of events that are complementary.

13.4.3 Impossible and Certain Events

Consider the following throws of a dice with sides marked as 1, 2, 3, 4, 5, 6.

- (i) What is the probability of getting a number 7 in a single throw of a dice?

We know that there are only six possible outcomes in a single throw of this dice. These outcomes are 1, 2, 3, 4, 5 and 6. Since, no face of the dice is marked 7, there is no outcome favourable to 7, i.e., the number of such outcomes is zero.

In other words, getting 7 in a single throw of a dice, is impossible. Suppose E = outcome of getting 7.

$$\text{So, } P(E) = \frac{0}{6} = 0$$

That is, the probability of an event which is impossible to occur is 0. Such an event is called an **impossible event**.

- (ii) What is the probability of getting 6 or a number less than 6 in a single throw of a dice?



Since, every face of a dice is marked with 6 or a number less than 6, it is sure that we will always get one of these when the dice is thrown once. So, the number of favourable outcomes is the same as the number of all possible outcomes, which is 6.

Suppose $E =$ (getting 6 or a number less than 6)

$$\text{Therefore, } P(E) = \frac{6}{6} = 1$$

So, the probability of an event which is sure (or certain) to occur is 1. Such an event is called a **sure event** or a **certain event**.

Note : From the definition of probability $P(E)$, we see that the numerator (number of outcomes favourable to the event E) is always less than or equal to the denominator (the number of all possible outcomes). Therefore, $0 \leq P(E) \leq 1$.



Try This

1. A child has a dice whose six faces show the letters A, B, C, D, E and F. The dice is thrown once. What is the probability of getting (i) A? (ii) D?
2. Which of the following cannot be the probability of an event?
(a) 2.3 (b) -1.5 (c) 15% (D) 0.7



Think and Discuss

1. Why is tossing a coin considered to be a fair way of deciding which team should get the ball at the beginning of any game?
2. Can $\frac{7}{2}$ be the probability of an event? Explain.
3. Which of the following arguments are correct and which are not correct? Give reasons.
 - i) If two coins are tossed simultaneously there are three possible outcomes - two heads, two tails or one of each. Therefore, for each of these outcomes, the probability is $\frac{1}{3}$.
 - ii) If a dice is thrown, there are two possible outcomes - an odd number or an even number. Therefore, the probability of getting an odd number is $\frac{1}{2}$.

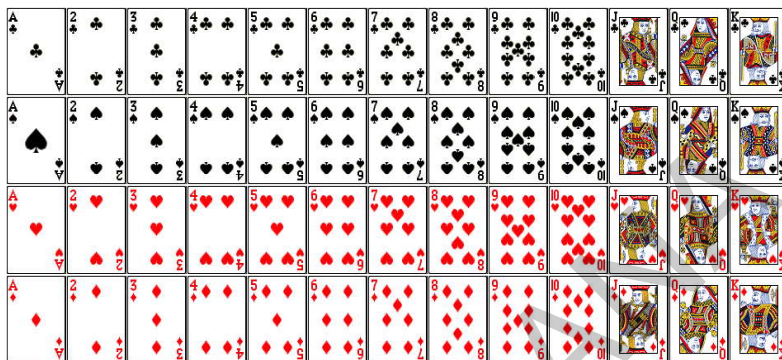
13.5 Deck of Cards and Probability

Have you seen a deck of playing cards?

A deck of playing cards consists of 52 cards which are divided into 4 suits of 13 cards each. They are black spades (\spadesuit), red hearts (\heartsuit), red diamonds (\diamondsuit) and black clubs (\clubsuit).



The cards in each suit are Ace, King, Queen, Jack, 10, 9, 8, 7, 6, 5, 4, 3 and 2. Kings, Queens and Jacks are called face cards. Many games are played with this deck of cards. Some games are played with part of the deck and some with two decks even. The study of probability has a lot to do with card and dice games as it helps players to estimate possibilities and predict how the cards could be distributed among players.



Example-4. One card is drawn from a well-shuffled deck of 52 cards. Calculate the probability that the card will (i) be an ace, (ii) not be an ace.

Solution : Well-shuffling ensures equally likely outcomes.

(i) There are 4 aces in a deck.

Let E be the event 'the card is an ace'.

The number of outcomes favourable to E = 4

The number of possible outcomes = 52 (Why ?)

$$\text{Therefore, } P(E) = \frac{4}{52} = \frac{1}{13}$$

(ii) Let F be the event 'card drawn is not an ace'.

The number of outcomes favourable to the event F = 52 - 4 = 48 (Why?)

The number of possible outcomes = 52

$$\text{Therefore, } P(F) = \frac{48}{52} = \frac{12}{13}$$

Alternate Method : Note that F is nothing but \bar{E} .

Therefore, we can also calculate P(F) as follows:

$$P(F) = P(\bar{E}) = 1 - P(E) = 1 - \frac{1}{13} = \frac{12}{13}$$



Try This

You have a single deck of well shuffled cards. Then,

1. What is the probability that the card drawn will be a queen?



2. What is the probability that it is a face card?
3. What is the probability it is a spade?
4. What is the probability that is the face card of spades?
5. What is the probability it is not a face card?

13.6 Use of Probability

Let us look at some more occasions where probability may be useful. We know that in sports some countries are strong and others are not so strong. We also know that when two players are playing it is not that they win equal times. The probability of winning of the player or team that wins more often is more than the probability of the other player or team. We also discuss and keep track of birthdays. Sometimes it happens that people we know have the same birthdays. Can we find out whether this is a common event or would it only happen occasionally. Classical probability helps us do this.

Example-5. Sangeeta and Reshma, play a tennis match. It is known that the probability of Sangeeta winning the match is 0.62. What is the probability of Reshma winning the match?

Solution : Let S and R denote the events that Sangeeta wins the match and Reshma wins the match, respectively.

The probability of Sangeeta's winning chances = $P(S) = 0.62$ (given)

The probability of Reshma's winning chances = $P(R) = 1 - P(S)$
 $= 1 - 0.62 = 0.38$ [R and S are complementary]

Example-6. Sarada and Hamida are friends. What is the probability that both will have (i) different birthdays? (ii) the same birthday? (ignoring a leap year).

Solution : Out of the two friends, one girl, say, Sarada's birthday can be any day of the year. Now, Hamida's birthday can also be any day of 365 days in the year. We assume that these 365 outcomes are equally likely.

(i) If Hamida's birthday is different from Sarada's, the number of favourable outcomes for her birthday is $365 - 1 = 364$

So, $P(\text{Hamida's birthday is different from Sarada's birthday}) = \frac{364}{365}$

(ii) $P(\text{Sarada and Hamida have the same birthday}) = 1 - P(\text{both have different birthdays})$

$$= 1 - \frac{364}{365} = \frac{1}{365} \quad [\because P(\bar{E}) = 1 - P(E)]$$



Example-7. There are 40 students in Class X of a school of whom 25 are girls and 15 are boys. The class teacher has to select one student as a class representative. She writes the name of each student on separate cards, the cards being identical. Then she puts cards in a box and shuffle them thoroughly. She then draws one card from the box. Compute the probability that the name written on the card is the name of (i) a girl? (ii) a boy?

Solution : There are 40 students, and only one name card has to be chosen.

The number of all possible outcomes is 40

(i) The number of outcomes favourable for a card with the name of a girl = 25 (Why?)

$$\therefore P(\text{card with name of a girl}) = P(\text{Girl}) = \frac{25}{40} = \frac{5}{8}$$

(ii) The number of outcomes favourable for a card with the name of a boy = 15 (Why?)

$$\therefore P(\text{card with name of a boy}) = P(\text{Boy}) = \frac{15}{40} = \frac{3}{8}$$

or $P(\text{Boy}) = 1 - P(\text{not Boy}) = 1 - P(\text{Girl}) = 1 - \frac{5}{8} = \frac{3}{8}$



Exercise - 13.1

1. Complete the following statements:

(i) Probability of an event E + Probability of the event 'not E' = _____

(ii) The probability of an event that cannot happen is _____.

Such an event is called _____

(iii) The probability of an event that is certain to happen is _____.

Such an event is called _____

(iv) The sum of the probabilities of all the elementary events of an experiment is _____

(v) The probability of an event is greater than or equal to _____ and less than or equal to _____

2. Which of the following experiments have equally likely outcomes? Explain.

(i) A driver attempts to start a car. The car starts or does not start.

(ii) A player attempts to shoot a basketball. She/he shoots or misses the shot.

(iii) A trial is made to answer a true-false question. The answer is right or wrong.

(iv) A baby is born. It is a boy or a girl.



3. If $P(E) = 0.05$, what is the probability of 'not E'?
4. A bag contains lemon flavoured candies only. Malini takes out one candy without looking into the bag. What is the probability that she takes out
 - (i) an orange flavoured candy? (ii) a lemon flavoured candy?
5. Rahim removes all the hearts from the cards. What is the probability of
 - i. Getting an ace from the remaining pack.
 - ii. Getting a diamonds.
 - iii. Getting a card that is not a heart.
 - iv. Getting the Ace of hearts.
6. It is given that in a group of 3 students, the probability of 2 students not having the same birthday is 0.992. What is the probability that the 2 students have the same birthday?
7. A dice is rolled once. Find the probability of getting
 - (i) a prime number (ii) a number lying between 2 and 6 (iii) an odd number.
8. What is the probability of selecting a red king from a deck of cards?
9. Make 5 more problems of this kind using dice, cards or birthdays and discuss with friends and teacher about their solutions.

13.7 More Applications of Probability

We have seen some examples of using probability. Think about the contents and ways probability has been used in these. We have seen again that probability of complementary events add to 1. Can you identify in the examples and exercises given above, and those that follow, complementary events and elementary events? Discuss with teachers and friends. Let us see more uses.

Example-8. A box contains 3 blue, 2 white, and 4 red marbles. If a marble is selected at random from the box, what is the probability that it will be

- (i) white? (ii) blue? (iii) red?

Solution : Saying that a marble is drawn at random means all the marbles are equally likely to be drawn.

\therefore The number of possible outcomes = $3 + 2 + 4 = 9$ (Why?)

Let W denote the event 'the marble is white', B denote the event 'the marble is blue' and R denote the event 'marble is red'.



(i) The number of outcomes favourable to the event $W = 2$

$$\therefore P(W) = \frac{2}{9}$$

Similarly, (ii) $P(B) = \frac{3}{9} = \frac{1}{3}$ and (iii) $P(R) = \frac{4}{9}$

Note that $P(W) + P(B) + P(R) = 1$.

Example-9. Harpreet tosses two different coins simultaneously (say, one is of ₹1 and other of ₹2). What is the probability that she gets at least one head?

Solution : We write H for 'head' and T for 'tail'. When two coins are tossed simultaneously, the possible outcomes are (H, H), (H, T), (T, H), (T, T), which are all equally likely. Here, (H, H) means heads on the first coin (say on ₹1) and also heads on the second coin (₹2). Similarly (H, T) means heads up on the first coin and tail up on the second coin and so on.

The outcomes favourable to the event E, 'at least one head' = {(H, H), (H, T) and (T, H)}.

So, the number of outcomes favourable to E is $n(E) = 3$.

$$\therefore P(E) = \frac{3}{4} \quad [\because \text{the total possible outcomes} = 4]$$

i.e., the probability that Harpreet gets at least one head = $\frac{3}{4}$

Check This

Did you observe that in all the examples discussed so far, the number of possible outcomes in each experiment was finite? If not, check it now.

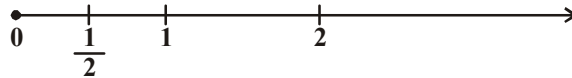
There are many experiments in which the outcome is number between two given numbers, or in which the outcome is every point within a circle or rectangle, etc. Can you count the number of all possible outcomes in such cases? As you know, this is not possible since there are infinitely many numbers between two given numbers, or there are infinitely many points within a circle. So, the definition of theoretical probability which you have learnt so far cannot be applied in the present form.

What is the way out? To answer this, let us consider the following example:

Example-10. In a musical chair game, the person playing the music has been advised to stop playing the music at any time within 2 minutes after she starts playing. What is the probability that the music will stop within the first half-minute after starting? (Not for Annual exam).



Solution : Here, the possible outcomes are all the numbers between 0 and 2. This is the portion of the number line from 0 to 2



Let E be the event that 'the music is stopped within the first half-minute'.

The outcomes favourable to E are points on the number line from 0 to $\frac{1}{2}$

The distance from 0 to 2 is 2, while the distance from 0 to $\frac{1}{2}$ is $\frac{1}{2}$

Since all the outcomes are equally likely, we can argue that, of the total distance (time) is 2 and the distance (time) favourable to the event E is $\frac{1}{2}$

$$\therefore P(E) = \frac{\text{Distance favourable to the event E}}{\text{Total distance in which outcomes can lie}} = \frac{\frac{1}{2}}{2} = \frac{1}{4}$$

We now try to extend this idea for finding the probability as the ratio of the favourable area to the total area.

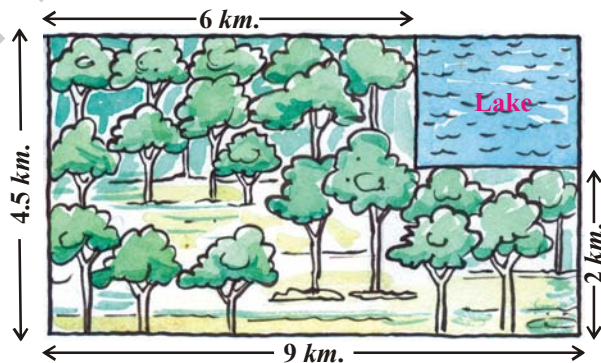
Example-11. A missing helicopter is reported to have crashed somewhere in the rectangular region as shown in the figure. What is the probability that it crashed inside the lake shown in the figure?

Solution : The helicopter is equally likely to crash anywhere in the region.

Area of the entire region where the helicopter can crash = $(4.5 \times 9) \text{ km}^2 = 40.5 \text{ km}^2$

Area of the lake = $(2.5 \times 3) \text{ km}^2 = 7.5 \text{ km}^2$

$$\therefore P(\text{helicopter crashed in the lake}) = \frac{7.5}{40.5} = \frac{5}{27}$$



Example-12. A carton consists of 100 shirts of which 88 are good, 8 have minor defects and 4 have major defects. Jhony, a trader, will only accept the shirts which are good, but Sujatha, another trader, will only reject the shirts which have major defects. One shirt is selected at random from the carton. What is the probability that

- (i) it is acceptable to Jhony? (ii) it is acceptable to Sujatha?



Solution : One shirt is selected at random from the carton of 100 shirts. Therefore, there are 100 equally likely outcomes.

(i) The number of outcomes favourable (i.e., acceptable) to Jhony = 88 (Why?)

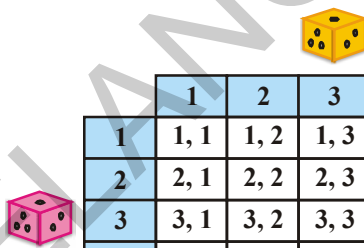
$$\text{Therefore, } P(\text{shirt is acceptable to Jhony}) = \frac{88}{100} = 0.88$$

(ii) The number of outcomes favourable to Sujatha = 88 + 8 = 96 (Why?)

$$\therefore P(\text{shirt is acceptable to Sujatha}) = \frac{96}{100} = 0.96$$

Example-13. Two dice, one red and one yellow are thrown at the same time. Write down all the possible outcomes. What is the probability that the sum of the two numbers appearing on the top of the dice is (i) 8 (ii) 13 (iii) less than or equal to 12?

Solution : When the red dice shows '1', the yellow dice could show any one of the numbers 1, 2, 3, 4, 5, 6. The same is true when the red dice shows '2', '3', '4', '5' or '6'. The possible outcomes of the experiment are shown in the figure; the first number in each ordered pair is the number appearing on the red dice and the second number is that on the yellow dice.



	1	2	3	4	5	6
1	1, 1	1, 2	1, 3	1, 4	1, 5	1, 6
2	2, 1	2, 2	2, 3	2, 4	2, 5	2, 6
3	3, 1	3, 2	3, 3	3, 4	3, 5	3, 6
4	4, 1	4, 2	4, 3	4, 4	4, 5	4, 6
5	5, 1	5, 2	5, 3	5, 4	5, 5	5, 6
6	6, 1	6, 2	6, 3	6, 4	6, 5	6, 6

Note that the pair (1, 4) is different from (4, 1). (Why?)

$$\therefore \text{the number of possible outcomes } n(S) = 6 \times 6 = 36.$$

(i) The outcomes favourable to the event 'the sum of the two numbers is 8' denoted by E, are: (2, 6), (3, 5), (4, 4), (5, 3), (6, 2) (See table)

i.e., the number of outcomes favourable to E is $n(E) = 5$.

$$\therefore P(E) = \frac{n(E)}{n(S)} = \frac{5}{36}$$

(ii) As there is no outcome favourable to the event F, 'the sum of two numbers is 13',

$$\therefore P(F) = \frac{0}{36} = 0$$


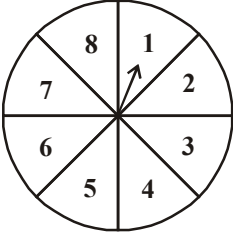
(iii) As all the outcomes are favourable to G, 'sum of two numbers is 12',

$$\therefore P(G) = \frac{36}{36} = 1$$





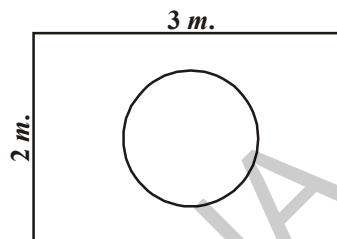
Exercise - 13.2

1. A bag contains 3 red balls and 5 black balls. A ball is selected at random from the bag. What is the probability that the ball selected is (i) red ? (ii) not red?
2. A box contains 5 red marbles, 8 white marbles and 4 green marbles. One marble is taken out of the box at random. What is the probability that the marble taken out will be (i) red? (ii) white ? (iii) not green?
3. A Kiddy bank contains hundred 50p coins, fifty ₹1 coins, twenty ₹2 coins and ten ₹5 coins. If it is equally likely that one of the coins will fall out when the bank is turned upside down, what is the probability that the coin (i) will be a 50 p coin? (ii) will not be a ₹5 coin?
4. Gopi buys a fish from a shop for his aquarium. The shopkeeper takes out one fish at random from a tank containing 5 male fish and 8 female fish (See figure). What is the probability that the fish taken out is a male fish?
5. A game of chance consists of spinning an arrow which comes to rest pointing at one of the numbers 1, 2, 3, 4, 5, 6, 7, 8 (See figure), and these are equally likely outcomes. What is the probability that it will point at
 - (i) 8 ?
 - (ii) an odd number?
 - (iii) a number greater than 2?
 - (iv) a number less than 9?
6. One card is selected from a well-shuffled deck of 52 cards. Find the probability of getting
 - (i) a king of red colour
 - (ii) a face card
 - (iii) a red face card
 - (iv) the jack of hearts
 - (v) a spade
 - (vi) the queen of diamonds
7. Five cards-the ten, jack, queen, king and ace of diamonds, are well-shuffled with their face downwards. One card is selected at random.
 - (i) What is the probability that the card is the queen?
 - (ii) If the queen is selected and put aside (without replacement), what is the probability that the second card selected is (a) an ace? (b) a queen?
8. 12 defective pens are accidentally mixed with 132 good ones. It is not possible to just look at a pen and tell whether or not it is defective. One pen is taken out at random from this lot. Determine the probability that the pen taken out is a good one.
9. A lot of 20 bulbs contain 4 defective ones. One bulb is selected at random from the lot. What is the probability that this bulb is defective? Suppose the bulb selected in previous case is not defective and is not replaced. Now one bulb is selected at random from the rest. What is the probability that this bulb is not defective?



10. A box contains 90 discs which are numbered from 1 to 90. If one disc is selected at random from the box, find the probability that it bears (i) a two-digit number (ii) a perfect square number (iii) a number divisible by 5.

11. Suppose you drop a die at random on the rectangular region shown in figure. What is the probability that it will land inside the circle with diameter 1m?



12. A lot consists of 144 ball pens of which 20 are defective and the others are good. The shopkeeper draws one pen at random and gives it to Sudha. What is the probability that (i) She will buy it? (ii) She will not buy it?

13. Two dice are rolled simultaneously and counts are added (i) complete the table given below:

Event : 'Sum on 2 dice'	2	3	4	5	6	7	8	9	10	11	12
Probability	$\frac{1}{36}$						$\frac{5}{36}$				$\frac{1}{36}$

- (ii) A student argues that 'there are 11 possible outcomes 2, 3, 4, 5, 6, 7, 8, 9, 10, 11 and 12. Therefore, each of them has a probability $\frac{1}{11}$ '. Do you agree with this argument? Justify your answer.

14. A game consists of tossing a one rupee coin 3 times and noting its outcome each time. Deskhitha wins if all the tosses give the same result i.e., three heads or three tails, and loses otherwise. Calculate the probability that she will lose the game.
15. A dice is thrown twice. What is the probability that (i) 5 will not come up either time? (ii) 5 will come up at least once? [**Hint** : Throwing a dice twice and throwing two dice simultaneously are treated as the same experiment].



Optional Exercise

[For extensive Learning]

- Two customers Shyam and Ekta are visiting a particular shop in the same week (Tuesday to Saturday). Each is equally likely to visit the shop on any day as on another day. What is the probability that both will visit the shop on (i) the same day? (ii) consecutive days? (iii) different days?
- A bag contains 5 red balls and some blue balls. If the probability of drawing a blue ball is double that of a red ball, what is the number of blue balls in the bag.
- A box contains 12 balls out of which x are black. If one ball is drawn at random from the box, what is the probability that it will be a black ball? If 6 more black balls are put in the box, the probability of drawing a black ball is now double of what it was before. Find x .



4. A jar contains 24 marbles, some are green and others are blue. If a marble is drawn at random from the jar, the probability that it is green is $\frac{2}{3}$. Find the number of blue marbles in the jar.

Project

"Comparing theoretical probability with statistical probability"

Observe the following situations as experiments and record the results. Also make the students to pronounce them.

- (i) Rolling a die 100 times a) even numbers b) odd numbers c) prime numbers. etc.
- (ii) Tossing a coin 100/200 times a) probability of getting head b) probability of getting tail.
- (iii) Rolling 2 dice at a time (iv) Balls of different colours, coloured cards / packs of cards.



What We Have Discussed

In this chapter, you have studied the following points:

1. We have dealt with experimental probability and theoretical probability.
2. The theoretical (classical) probability of an event E, written as P(E), is defined as

$$P(E) = \frac{\text{Number of outcomes favourable to E}}{\text{Total number of all possible outcomes of the experiment}}$$

where we assume that the outcomes of the experiment are equally likely.

3. The probability of a sure event (or certain event) is 1.
4. The probability of an impossible event is 0.
5. The probability of an event E is P(E) and P(E) is a number such that $0 \leq P(E) \leq 1$
6. An event having only one outcome is called an elementary event. The sum of the probabilities of all the elementary events of an experiment is 1.
7. For any event E, $P(E) + P(\bar{E}) = 1$, where \bar{E} stands for 'not E'. E and \bar{E} are called complementary events.
8. Some more terms used in the chapter are given below:

- Random experiment** : For random experiments, the results are known well in advance, but the result of the specific performance cannot be predicted.
- Equally likely events** : Two or more events are said to be equally likely if each one of them has an equal chance of occurrence.
- Mutually Exclusive events** : Two or more events are mutually exclusive if the occurrence of each event prevents the every other event.
- Exhaustive events** : Two or more events are said to be exhaustive, if the union of their outcomes is the entire sample space.
- Complementary events** : Two events are said to be complementary, if they are mutually exclusive and also exhaustive. (OR) Two events are said to be complementary if occurrence of an event prevents the occurrence of the other and the union of their outcomes is the entire sample space.
- Sure events** : An event which will definitely occur is called a sure event. And its probability is 1 (one) space.
- Impossible event** : An event which cannot occur on any account is called an impossible event.





14.1 Introduction

Ganesh recorded the marks of 26 children in his class in the mathematics Summative Assessment - I in the register as follows:

Arjun	76	Narayana	12
Kamini	82	Suresh	24
Shafik	64	Durga	39
Keshav	53	Shiva	41
Lata	90	Raheem	69
Rajender	27	Radha	73
Ramu	34	Kartik	94
Sudha	74	Joseph	89
Krishna	76	Ikram	64
Somu	65	Laxmi	46
Gouri	47	Sita	19
Upendra	54	Rehana	53
Ramaiah	36	Anitha	69

Whether the recorded data is organised data or not? Why?

His teacher asked him to report on how his class students have performed in mathematics in their Summative Assessment - I.



Ganesh prepared the following table to understand the performance of his class:

Marks	Number of children
0 - 33	4
34 - 50	6
51 - 75	10
76 - 100	6

Is the data given in the above table grouped or ungrouped?

He showed this table to his teacher and the teacher appreciated him for organising the data to be understood easily. We can see that most children have got marks between 51-75. Do you think that Ganesh should have used smaller range? Why or why not?

In the previous class, you had learnt about the difference between grouped and ungrouped data as well as how to present this data in the form of tables. You had also learnt to calculate the mean value for ungrouped data. Let us recall this learning and then learn to calculate the mean, median and mode for grouped data.

14.2 Mean of Ungrouped Data

We know that the mean (or average) of observations is sum of the values of all the observations divided by the total number of observations. Let x_1, x_2, \dots, x_n be observations with respective frequencies f_1, f_2, \dots, f_n . This means that observation x_1 occurs f_1 times, x_2 occurs f_2 times, and so on.

Now, the sum of all the observations = $f_1x_1 + f_2x_2 + \dots + f_nx_n$, and the number of observations = $f_1 + f_2 + \dots + f_n$.

So, the mean \bar{x} of the data is given by

$$\bar{x} = \frac{f_1x_1 + f_2x_2 + \dots + f_nx_n}{f_1 + f_2 + \dots + f_n}$$

Recall that we can write this in short, using the Greek letter Σ (read as sigma) which means summation i.e., $\bar{x} = \frac{\Sigma f_i x_i}{\Sigma f_i}$

Example-1. The marks obtained in mathematics by 30 students of Class X in Rangayapally school are given in the below table. Find the mean of the marks obtained by the students.

Marks obtained (x_i)	10	20	36	40	50	56	60	70	72	80	88	92	95
Number of student (f_i)	1	1	3	4	3	2	4	4	1	1	2	3	1



Solution : Let us re-organize this data and find the sum of all observations.

Marks obtained (x_i)	Number of students (f_i)	$f_i x_i$
10	1	10
20	1	20
36	3	108
40	4	160
50	3	150
56	2	112
60	4	240
70	4	280
72	1	72
80	1	80
88	2	176
92	3	276
95	1	95
Total	$\sum f_i = 30$	$\sum f_i x_i = 1779$

$$\text{So, } \bar{x} = \frac{\sum f_i x_i}{\sum f_i} = \frac{1779}{30} = 59.3$$

\therefore The mean marks = 59.3.

In most of our real life situations, data is usually so large that to make a meaningful study, it needs to be condensed as a grouped data. So, we need to convert ungrouped data into grouped data and derive some method to find its mean.

Let us convert the ungrouped data of Example 1 into grouped data by forming class-intervals of width, say 15. Remember that while allocating frequencies to each class-interval, students whose score is equal to in any **upper class-boundary** would be considered in the next class, e.g., 4 students who have obtained 40 marks would be considered in the class-interval 40-55 and not in 25-40. With this convention in our mind, let us form a grouped frequency distribution table.

Class interval	10-25	25-40	40-55	55-70	70-85	85-100
Number of students	2	3	7	6	6	6



Now, for each class-interval, we require a point which would serve as the representative of the whole class. ***It is assumed that the frequency of each class-interval is centred around its mid-point.*** So, the *mid-point* of each class can be chosen to represent the observations falling in that class and is called the class mark. Recall that we find the class mark by finding the average of the upper and lower limit of the class.

$$\text{Class mark} = \frac{\text{Upper class limit} + \text{Lower class limit}}{2}$$

For the class 10 -25, the class mark is $\frac{10+25}{2}=17.5$. Similarly, we can find the class marks of the remaining class intervals. We put them in the table. These class marks serve as our x_i 's. We can now proceed to compute the mean in the same manner as in the previous example.

Class interval	Number of students (f_i)	Class Marks (x_i)	$f_i x_i$
10-25	2	17.5	35.0
25-40	3	32.5	97.5
40-55	7	47.5	332.5
55-70	6	62.5	375.0
70-85	6	77.5	465.0
85-100	6	92.5	555.0
Total	$\sum f_i=30$		$\sum f_i x_i=1860.0$

The sum of the values in the last column gives us $\sum f_i x_i$. So, the mean \bar{x} of the given data is given by

$$\bar{x} = \frac{\sum f_i x_i}{\sum f_i} = \frac{1860}{30} = 62$$

This new method of finding the mean is known as the **Direct Method**.

We observe that in the above cases we are using the same data and employing the same formula for calculating the mean but the results obtained are different. In example (1), 59.3 is the exact mean and 62 is the approximate mean. Can you think why this is so?





Think and discuss

1. The mean value can be calculated from both ungrouped and grouped data. Which one do you think is more accurate? Why?
2. When is it more convenient to use grouped data for analysis?

Sometimes when the numerical values of x_i and f_i are large, finding the product of x_i and f_i becomes tedious and time consuming. So, for such situations, let us think of a method of reducing these calculations.

We can do nothing with the f_i 's, but we can change each x_i to a smaller number so that our calculations become easy. How do we do this? How about subtracting a fixed number from each of these x_i 's? Let us try this method for the data in example 1.

The first step is to choose one among the x_i 's as the *assumed mean*, and denote it by ' a '. Also, to further reduce our calculation work, we may take ' a ' to be that x_i which lies in the centre of x_1, x_2, \dots, x_n . So, we can choose $a = 47.5$ or $a = 62.5$. Let us choose $a = 47.5$.

The second step is to find the **deviation** of ' a ' from each of the x_i 's, i.e. $(x_i - a)$ which we denote as d_i .

$$\text{i.e., } d_i = x_i - a = x_i - 47.5$$

The third step is to find the product of d_i with the corresponding f_i , and take the sum of all the $f_i d_i$'s. These calculations are shown in table given below-

Class interval	Number of students (f_i)	Class Marks (x_i)	$d_i = x_i - 47.5$ $d_i = x_i - a$	$f_i d_i$
10-25	2	17.5	-30	-60
25-40	3	32.5	-15	-45
40-55	7	47.5 (a)	0	0
55-70	6	62.5	15	90
70-85	6	77.5	30	180
85-100	6	92.5	45	270
Total	$\sum f_i = 30$			$\sum f_i d_i = 435$

So, from the above table, the mean of the deviations, $\bar{d} = \frac{\sum f_i d_i}{\sum f_i}$

Now, let us find the relation between \bar{d} and \bar{x} .



Since, in obtaining d_i we subtracted 'a' from each x_i so, in order to get the mean \bar{x} we need to add 'a' to \bar{d} . This can be explained mathematically as:

$$\begin{aligned} \text{Mean of deviations, } \quad \bar{d} &= \frac{\sum f_i d_i}{\sum f_i} \\ \text{So,} \quad \bar{d} &= \frac{\sum f_i (x_i - a)}{\sum f_i} \\ &= \frac{\sum f_i x_i}{\sum f_i} - \frac{\sum f_i a}{\sum f_i} \\ &= \bar{x} - a \frac{\sum f_i}{\sum f_i} \\ \bar{d} &= \bar{x} - a \\ \text{Therefore} \quad \bar{x} &= a + \frac{\sum f_i d_i}{\sum f_i} \end{aligned}$$



Substituting the values of a , $\sum f_i d_i$ and $\sum f_i$ from the table, we get

$$\bar{x} = 47.5 + \frac{435}{30} = 47.5 + 14.5 = 62$$

Therefore, the mean of the marks obtained by the students is 62.

The method discussed above is called the **Deviation method (or) Assumed Mean Method**.



Activity

Consider the data given in example 1 and calculate the arithmetic mean by deviation method by taking successive values of x_i i.e., 17.5, 32.5, ... as assumed means. Now discuss the following:

1. Are the values of arithmetic mean in all the above cases equal?
2. If we take the actual mean as the assumed mean, how much will $\sum f_i d_i$ be?
3. Reason about taking any mid-value (class mark) as assumed mean?

Observe that in the table given below the values in Column 4 are all multiples of 15. If we divide all the values of Column 4 by 15, we would get smaller numbers which we then multiply with f_i . (Here, 15 is the class size of each class interval. (or HCF of the values in column 4)

So, let $u_i = \frac{x_i - a}{h}$, where a is the assumed mean and h is the class size.



Now, we calculate u_i in this way and continue as before (i. e., find $f_i u_i$ and then $\sum f_i u_i$). Taking $h = 15$ [generally size of the class is taken as h but it need not be size of the class always].

$$\text{Let } \bar{u} = \frac{\sum f_i u_i}{\sum f_i}.$$

Class interval	Number of students (f_i)	Class Marks (x_i)	$d_i = x_i - a$	$u_i = \frac{x_i - a}{h}$	$f_i u_i$
10-25	2	17.5	-30	-2	-4
25-40	3	32.5	-15	-1	-3
40-55	7	47.5	0	0	0
55-70	6	62.5	15	1	6
70-85	6	77.5	30	2	12
85-100	6	92.5	45	3	18
Total	$\sum f_i = 30$				$\sum f_i u_i = 29$

Here again, let us find the relation between \bar{u} and \bar{x} .

We have $u_i = \frac{x_i - a}{h}$

So
$$\bar{u} = \frac{\sum f_i u_i}{\sum f_i}$$

$$\bar{u} = \frac{\sum f_i \frac{(x_i - a)}{h}}{\sum f_i}$$

$$= \frac{1}{h} \left[\frac{\sum f_i x_i}{\sum f_i} - \frac{\sum f_i a}{\sum f_i} \right]$$

$$= \frac{1}{h} (\bar{x} - a)$$

$$h\bar{u} = \bar{x} - a$$

$$\bar{x} = a + h\bar{u}$$

Therefore,
$$\bar{x} = a + h \left[\frac{\sum f_i u_i}{\sum f_i} \right].$$



or
$$\bar{x} = a + \left(\frac{\sum f_i u_i}{\sum f_i} \right) \times h$$

Substituting the values of a , $\sum f_i u_i h$ and $\sum f_i$ from the table, we get

$$\begin{aligned} \bar{x} &= 47.5 + \left(\frac{29}{30} \right) \times 15 \\ &= 47.5 + 14.5 = 62 \end{aligned}$$

So, the mean marks obtained by a student are 62.

The method discussed above is called the **Step-deviation** method.

We note that:

- The step-deviation method will be convenient to apply if all the d_i 's have a common factor.
- The mean obtained by all the three methods is same.
- The assumed mean method and step-deviation method are just simplified forms of the direct method.
- The formula $\bar{x} = a + h\bar{u}$ still holds if a and h are not as given above, but are any non-zero numbers such that $u_i = \frac{x_i - a}{h}$.

Let us apply these methods in more examples.

Example-2. The table below gives the percentage distribution of female teachers in the primary schools of rural areas of various states and union territories (U.T.) of India. Find the mean percentage of female teachers using all the three methods.

Percentage of female teachers	15-25	25-35	35-45	45-55	55-65	65-75	75-85
Number of States/U.T.	6	11	7	4	4	2	1

Source : *Seventh All India School Education Survey conducted by NCERT*

Solution : Let us find the class marks x_i of each class, and arrange them in a table.

Here, we take $a = 50$ and $h = 10$.

Then $d_i = x_i - 50$ and $u_i = \frac{x_i - 50}{10}$.



Now find d_i and u_i and write them in the table

Percentage of female teachers C.I	Number of States/U.T. f_i	x_i	$d_i = x_i - 50$	$u_i = \frac{x_i - 50}{10}$	$f_i x_i$	$f_i d_i$	$f_i u_i$
15 – 25	6	20	-30	-3	120	-180	-18
25 – 35	11	30	-20	-2	330	-220	-22
35 – 45	7	40	-10	-1	280	-70	-7
45 – 55	4	50	0	0	200	0	0
55 – 65	4	60	10	1	240	40	4
65 – 75	2	70	20	2	140	40	4
75 – 85	1	80	30	3	80	30	3
Total	35				1390	-360	-36

From the above table, we obtain $\sum f_i = 35$, $\sum f_i x_i = 1390$, $\sum f_i d_i = -360$, $\sum f_i u_i = -36$.

Using the direct method, $\bar{x} = \frac{\sum f_i x_i}{\sum f_i} = \frac{1390}{35} = 39.71$.

Using the assumed mean method $\bar{x} = a + \frac{\sum f_i d_i}{\sum f_i} = 50 + \frac{-360}{35} = 50 - 10.29 = 39.71$.

Using the step-deviation method $\bar{x} = a + \left(\frac{\sum f_i u_i}{\sum f_i} \right) \times h = 50 + \frac{-36}{35} \times 10 = 39.71$.

Therefore, the mean percentage of female teachers in the primary schools of rural areas is 39.71.



Think and Discuss

1. Is the result obtained by all the three methods same?
2. If x_i and f_i are sufficiently small, then which method is an appropriate choice?
3. If x_i and f_i are numerically large numbers, then which methods are appropriate to use?

Even if the class sizes are unequal, and x_i are large numerically, we can still apply the step-deviation method by taking h to be a suitable divisor of all the d_i 's.

Example-3. The below distribution shows the number of wickets taken by bowlers in one-day cricket matches. Find the mean number of wickets by choosing a suitable method. What does the mean signify?

Number of wickets	20 - 60	60 - 100	100 - 150	150 - 250	250 - 350	350 - 450
Number of bowlers	7	5	16	12	2	3



Solution : Here, the class size varies, and the x_i 's are large. Let us still apply the step deviation method with $a = 200$ and $h = 20$. Then, we obtain the data as given in the table.

Number of wickets	Number of bowlers (f_i)	x_i	$d_i = x_i - a$	$u_i = \frac{x_i - a}{h}$ ($h = 20$)	$f_i u_i$
20 – 60	7	40	-160	-8	-56
60 – 100	5	80	-120	-6	-30
100 – 150	16	125	-75	-3.75	-60
150 – 250	12	200 (a)	0	0	0
250 – 350	2	300	100	5	10
350 – 450	3	400	200	10	30
Total	45				-106

$$\text{So } \bar{x} = a + \left(\frac{\sum f_i u_i}{\sum f_i} \right) \times h = 200 + \frac{-106}{45} \times 20 = 200 - 47.11 = 152.89$$

Thus, the average number of wickets taken by these 45 bowlers in one-day cricket is 152.89.

Classroom Project :

1. Collect the marks obtained by all the students of your class in Mathematics in the recent examination conducted in your school. Form a grouped frequency distribution of the data obtained. Do the same regarding other subjects and compare. Find the mean in each case using a method you find appropriate.
2. Collect the daily maximum temperatures recorded for a period of 30 days in your city. Present this data as a grouped frequency table. Find the mean of the data using an appropriate method.
3. Measure the heights of all the students of your class and form a grouped frequency distribution table of this data. Find the mean of the data using an appropriate method.



Exercise - 14.1

1. A survey was conducted by a group of students as a part of their environment awareness programme, in which they collected the following data regarding the number of plants in 20 houses in a locality. Find the mean number of plants per house.

Number of plants	0 - 2	2 - 4	4 - 6	6 - 8	8 - 10	10 - 12	12 - 14
Number of houses	1	2	1	5	6	2	3



2. Consider the following distribution of daily wages of 50 workers of a factory.

Daily wages in (₹)	200 - 250	250 - 300	300 - 350	350 - 400	400– 450
Number of workers	12	14	8	6	10

Find the mean daily wages of the workers of the factory by using an appropriate method.

3. The following distribution shows the daily pocket allowance of children of a locality. The mean pocket allowance is ₹ 18. Find the missing frequency.

Daily pocket allowance (₹)	11 - 13	13 - 15	15 - 17	17 - 19	19 - 21	21 - 23	23 - 25
Number of children	7	6	9	13	f	5	4

4. Thirty women were examined in a hospital by a doctor and their heart beats per minute were recorded and summarised as shown. Find the mean heart beats per minute for these women, choosing a suitable method.

Number of heart beats/minute	65-68	68-71	71-74	74-77	77-80	80-83	83-86
Number of women	2	4	3	8	7	4	2

5. In a retail market, fruit vendors were selling oranges kept in packing baskets. These baskets contained varying number of oranges. The following was the distribution of oranges.

Number of oranges	10-14	15-19	20-24	25-29	30-34
Number of baskets	15	110	135	115	25

Find the mean number of oranges kept in each basket. Which method of finding the mean did you choose?

6. The table below shows the daily expenditure on food of 25 households in a locality.

Daily expenditure (₹)	100-150	150-200	200-250	250-300	300-350
Number of house holds	4	5	12	2	2

Find the mean daily expenditure on food by a suitable method.

7. To find out the concentration of SO_2 in the air (in parts per million, i.e., ppm), the data was collected for 30 localities in a certain city and is presented below:

Concentration of SO_2 in ppm	0.00-0.04	0.04-0.08	0.08-0.12	0.12-0.16	0.16-0.20	0.20-0.24
Frequency	4	9	9	2	4	2

Find the mean concentration of SO_2 in the air.



8. A class teacher has the following attendance record of 40 students of a class for the whole term. Find the mean number of days a student was present out of 56 days in the term.

Number of days	35-38	38-41	41-44	44-47	47-50	50-53	53-56
Number of students	1	3	4	4	7	10	11

9. The following table gives the literacy rate (in percentage) of 35 cities. Find the mean literacy rate.

Literacy rate (in %)	45-55	55-65	65-75	75-85	85-95
Number of cities	3	10	11	8	3

14.3 Mode

A mode is that value among the observations which occurs most frequently.

Before learning, how to calculate the mode of grouped data, let us first recall how we found the mode for ungrouped data through the following example.

Example-4. The wickets taken by a bowler in 10 cricket matches are as follows: 2, 6, 4, 5, 0, 2, 1, 3, 2, 3. Find the mode of the data.

Solution : Let us arrange the observations in order i.e., 0, 1, 2, 2, 2, 3, 3, 4, 5, 6

Clearly, 2 is the number of wickets taken by the bowler in the maximum number of matches (i.e., 3 times). So, the mode of this data is 2.



Do This

- Find the mode of the following data.
 - 5, 6, 9, 10, 6, 12, 3, 6, 11, 10, 4, 6, 7.
 - 20, 3, 7, 13, 3, 4, 6, 7, 19, 15, 7, 18, 3.
 - 2, 2, 2, 3, 3, 3, 4, 4, 4, 5, 5, 5, 6, 6, 6.
- Is the mode always at the centre of the data?
- Does the mode change, if another observation is added to the data in example 4? Comment.
- If the maximum value of an observation in the data in Example 4 is changed to 8, would the mode of the data be affected? Comment.



In a grouped frequency distribution, it is not possible to determine the mode by looking at the frequencies. Here, we can only locate a class with the maximum frequency, called the modal class. The mode is a value inside the modal class, and is given by the formula.

$$\text{Mode} = l + \left(\frac{f_1 - f_0}{2f_1 - f_0 - f_2} \right) \times h$$

where, l = lower boundary of the modal class,

h = size of the modal class interval,

f_1 = frequency of the modal class,

f_0 = frequency of the class preceding the modal class,

f_2 = frequency of the class succeeding the modal class.

Let us consider the following examples to illustrate the use of this formula.

Example-5. A survey conducted on 20 households in a locality by a group of students resulted in the following frequency table for the number of family members in a household.

Family size	1-3	3-5	5-7	7-9	9-11
Number of families	7	8	2	2	1

Find the mode of this data.

Solution : Here the maximum class frequency is 8, and the class corresponding to this frequency is 3-5. So, the modal class is 3-5.

Now,

modal class = 3-5, boundary limit (l) of modal class = 3, class size (h) = 2

frequency of the modal class (f_1) = 8,

frequency of class preceding the modal class (f_0) = 7,

frequency of class succeeding the modal class (f_2) = 2.

Now, let us substitute these values in the formula-

$$\begin{aligned} \text{Mode} &= l + \left(\frac{f_1 - f_0}{2f_1 - f_0 - f_2} \right) \times h \\ &= 3 + \left(\frac{8 - 7}{2 \times 8 - 7 - 2} \right) \times 2 = 3 + \frac{2}{7} = 3.286 \end{aligned}$$

Therefore, the mode of the data above is 3.286.

Example-6. The marks distribution of 30 students in a mathematics examination are given in the following table. Find the mode of this data. Also compare and interpret the mode and the mean.



Class interval	Number of students (f_i)	Class Marks (x_i)	$f_i x_i$
10-25	2	17.5	35.0
25-40	3	32.5	97.5
40-55	7	47.5	332.5
55-70	6	62.5	375.0
70-85	6	77.5	465.0
85-100	6	92.5	555.0
Total	$\sum f_i = 30$		$\sum f_i x_i = 1860.0$

Solution : Since the maximum number of students (i.e., 7) have got marks in the interval, 40-65 the modal class is 40 - 55.

The lower boundary (l) of the modal class = 40,

the class size (h) = 15,

the frequency of modal class (f_1) = 7,

the frequency of the class preceding the modal class (f_0) = 3 and

the frequency of the class succeeding the modal class (f_2) = 6.

Now, using the formula:

$$\begin{aligned} \text{Mode} &= l + \left(\frac{f_1 - f_0}{2f_1 - f_0 - f_2} \right) \times h \\ &= 40 + \left(\frac{7 - 3}{2 \times 7 - 6 - 3} \right) \times 15 = 40 + 12 = 52 \end{aligned}$$

Interpretation : The mode marks is 52. Now, from Example 1, we know that the mean marks is 62. So, the maximum number of students obtained 52 marks, while on an average a student obtained 62 marks.



Think and Discuss

- It depends upon the demand of the situation whether we are interested in finding the average marks obtained by the students or the marks obtained by most of the students.
 - What do we find in the first situation?
 - What do we find in the second situation?
- Can mode be calculated for grouped data with unequal class sizes?





Exercise - 14.2

1. The following table shows the ages of the patients admitted in a hospital on a particular day:

Age (in years)	5-15	15-25	25-35	35-45	45-55	55-65
Number of patients	6	11	21	23	14	5

Find the mode and the mean of the data given above. Compare and interpret the two measures of central tendency.

2. The following data gives the information on the observed life times (in hours) of 225 electrical components :

Lifetimes (in hours)	0 - 20	20 - 40	40 - 60	60 - 80	80 - 100	100 - 120
Frequency	10	35	52	61	38	29

Determine the modal lifetimes of the components.

3. The following data gives the distribution of total monthly household expenditure of 200 families of Gummadidala village. Find the modal monthly expenditure of the families. Also, find the mean monthly expenditure :

Expenditure (₹)	1000-1500	1500-2000	2000-2500	2500-3000	3000-3500	3500-4000	4000-4500	4500-5000
Number of families	24	40	33	28	30	22	16	7

4. The following distribution gives the state-wise, teacher-student ratio in higher secondary schools of India. Find the mode and mean of this data. Interpret the two measures.

Number of students	15-20	20-25	25-30	30-35	35-40	40-45	45-50	50-55
Number of States	3	8	9	10	3	0	0	2

5. The given distribution shows the number of runs scored by some top batsmen of the world in one-day international cricket matches.

Blood	300-4000	4000-5000	5000-6000	6000-7000	7000-8000	8000-9000	9000-10000	10000-11000
Number of batsmen	4	18	9	7	6	3	1	1

Find the mode of the data.



6. A student noted the number of cars passing through a spot on a road for 100 intervals, each of 3 minutes, and summarised this in the table given below.

Number of cars	0 - 10	10 - 20	20 - 30	30 - 40	40 - 50	50 - 60	60 - 70	70 - 80
Frequency	7	14	13	12	20	11	15	8

Find the mode of the data.

14.4 Median of Grouped Data

Median is a measure of central tendency which gives the value of the middle-most observation in the data. Recall that for finding the median of ungrouped data, we first arrange the data values or the observations in ascending order.

Then, if n is odd, the median is the $\left(\frac{n+1}{2}\right)^{th}$ observation and

if n is even, then the median will be the average of the $\left(\frac{n}{2}\right)^{th}$ and $\left(\frac{n}{2}+1\right)^{th}$ observations.

Suppose, we have to find the median of the following data, which is about the marks, out of 50 obtained by 100 students in a test :

Marks obtained	20	29	28	33	42	38	43	25
Number of students	6	28	24	15	2	4	1	20

First, we arrange the marks in ascending order and prepare a frequency table as follows :

Marks obtained	Number of students (frequency)
20	6
25	20
28	24
29	28
33	15
38	4
42	2
43	1
Total	100



Here $n = 100$, which is even. The median will be the average of the $\left(\frac{n}{2}\right)^{th}$ and the $\left(\frac{n}{2} + 1\right)^{th}$ observations, i.e., the 50^{th} and 51^{st} observations. To find the position of these middle values, we construct cumulative frequency.

Marks obtained	Number of students	Cumulative frequency
20	6	6
upto 25	$6 + 20 = 26$	26
upto 28	$26 + 24 = 50$	50
upto 29	$50 + 28 = 78$	78
upto 33	$78 + 15 = 93$	93
upto 38	$93 + 4 = 97$	97
upto 42	$97 + 2 = 99$	99
upto 43	$99 + 1 = 100$	100

Now we add another column depicting this information to the frequency table above and name it as *cumulative frequency column*.

From the table above, we see that :

50^{th} observation is 28 (Why?)

51^{st} observation is 29

$$\text{Median} = \frac{28 + 29}{2} = 28.5 \text{ marks}$$

Remark : The above table is known as *Cumulative Frequency Table*. The median marks 28.5 conveys the information that about 50% students obtained marks less than 28.5 and another 50% students obtained marks more than 28.5.

Consider a grouped frequency distribution of marks obtained, out of 100, by 53 students, in a certain examination, as shown in the following table.

Marks	0-10	10-20	20-30	30-40	40-50	50-60	60-70	70-80	80-90	90-100
Number of students	5	3	4	3	3	4	7	9	7	8



From the table, try to answer the following questions :

How many students have scored marks less than 10? The answer is clearly 5.

How many students have scored less than 20 marks? Observe that the number of students who have scored less than 20 include the number of students who have scored marks from 0-10 as well as the number of students who have scored marks from 10-20. So, the total number of students with marks less than 20 is $5 + 3$, i.e., 8. We say that the cumulative frequency of the class 10-20 is 8. (As shown in table.)

Similarly, we can compute the cumulative frequencies of the other classes, i.e., the number of students with marks less than 30, less than 40, ..., less than 100.

This distribution is called the cumulative frequency distribution of the less than type. Here 10, 20, 30, ..., 100, are the upper boundaries of the respective class intervals.

We can similarly make the table for the number of students with scores more than or equal to 0 (this number is same as sum of all the frequencies), more than or equal to 10 (above sum minus the frequency of the first class interval), more than or equal to 20 (this number is same as the sum of all frequencies minus the sum of the frequencies of the first two class intervals), and so on.

We observe that all 53 students have scored marks more than or equal to 0.

Marks obtained	Number of students (Cumulative frequency)
Less than 10	5
Less than 20	$5 + 3 = 8$
Less than 30	$8 + 4 = 12$
Less than 40	$12 + 3 = 15$
Less than 50	$15 + 3 = 18$
Less than 60	$18 + 4 = 22$
Less than 70	$22 + 7 = 29$
Less than 80	$29 + 9 = 38$
Less than 90	$38 + 7 = 45$
Less than 100	$45 + 8 = 53$

Marks obtained	Number of students (Cumulative frequency)
More than or equal to 0	53
More than or equal to 10	$53 - 5 = 48$
More than or equal to 20	$48 - 3 = 45$
More than or equal to 30	$45 - 4 = 41$
More than or equal to 40	$41 - 3 = 38$
More than or equal to 50	$38 - 3 = 35$
More than or equal to 60	$35 - 4 = 31$
More than or equal to 70	$31 - 7 = 24$
More than or equal to 80	$24 - 9 = 15$
More than or equal to 90	$15 - 7 = 8$



Since there are 5 students scoring marks in the interval 0-10, this means that there are $53-5 = 48$ students getting more than or equal to 10 marks. Continuing in the same manner, we get the number of students scoring 20 or above as $48-3 = 45$, 30 or above as $45-4 = 41$, and so on, in the same manner we can even find the number of students scoring 90 or above as shown in the table.

This table above is called a cumulative frequency distribution of the more than type. Here 0, 10, 20, ..., 90 give the lower boundaries of the respective class intervals.

Now, to find the median of grouped data, we can make use of any of these cumulative frequency distributions.

Now in a grouped data, we may not be able to find the middle observation by looking at the cumulative frequencies as the middle observation will be some value in a class interval. It is, therefore, necessary to find the value inside a class that divides the whole distribution into two halves. But which class should this be?

To find this class, we find the cumulative frequencies of all the classes and $\frac{n}{2}$. We now locate the class whose cumulative frequency exceeds $\frac{n}{2}$ for the first time. This is called the median class.

Marks	Number of students (f)	Cumulative frequency (cf)
0-10	5	5
10-20	3	8
20-30	4	12
30-40	3	15
40-50	3	18
50-60	4	22
60-70	7	29
70-80	9	38
80-90	7	45
90-100	8	53

In the distribution above, $n = 53$. So $\frac{n}{2} = 26.5$. Now 60-70 is the class whose cumulative frequency 29 is greater than (and nearest to) $\frac{n}{2}$, i.e., 26.5. Therefore, 60-70 is the median class.



After finding the median class, we use the following formula for calculating the median.

$$\text{Median (M)} = l + \left(\frac{\frac{n}{2} - cf}{f} \right) \times h$$

where l = lower boundary of median class,

n = number of observations,

cf = cumulative frequency of class preceding the median class,

f = frequency of median class,

h = class size (size of the median class).

Substituting the values from the table,

$$\frac{n}{2} = 26.5, \quad l = 60, \quad cf = 22, \quad f = 7, \quad h = 10$$

in the formula above, we get

$$\begin{aligned} \text{Median} &= 60 + \left[\frac{26.5 - 22}{7} \right] \times 10 \\ &= 60 + \frac{45}{7} \\ &= 66.4 \end{aligned}$$

So, about half the students have scored marks less than 66.4, and the other half have scored marks more than 66.4.

Example-7. A survey regarding the heights (in cm) of 51 girls of Class X of a school was conducted and data was obtained as shown in table. Find their median.

Height (in cm)	Number of girls
Less than 140	4
Less than 145	11
Less than 150	29
Less than 155	40
Less than 160	46
Less than 165	51



Solution : To calculate the median height, we need to find the class intervals and their corresponding frequencies. The given distribution being of the *less than type*, 140, 145, 150, . . . , 165 give the upper limits of the corresponding class intervals. So, the classes should be below 140, 140 - 145, 145 - 150, . . . , 160 - 165.

Class intervals	Frequency	Cumulative frequency
Below 140	4	4
140-145	7	11
145-150	18	29
150-155	11	40
155-160	6	46
160-165	5	51

Observe that from the given distribution, we find that there are 4 girls with height less than 140, i.e., the frequency of class interval below 140 is 4. Now, there are 11 girls with heights less than 145 and 4 girls with height less than 140. Therefore, the number of girls with height in the interval 140 – 145 is $11 - 4 = 7$. Similarly, the frequencies can be calculated as shown in table.

Number of observations, $n = 51$

$$\frac{n}{2} = \frac{51}{2} = 25.5^{\text{th}} \text{ observation, which lies in the class } 145 - 150.$$

\therefore 145 – 150 is the median class

Then, l (the lower boundary) = 145,

cf (the cumulative frequency of the class preceding 145– 150) = 11,

f (the frequency of the median class 145– 150) = 18 and

h (the class size) = 5.

$$\begin{aligned} \text{Using the formula, Median} &= l + \frac{\left(\frac{n}{2} - cf\right)}{f} \times h \\ &= 145 + \frac{(25.5 - 11)}{18} \times 5 \\ &= 145 + \frac{72.5}{18} = 149.03. \end{aligned}$$



So, the median height of the girls is 149.03 cm. This means that the height of about 50% of the girls is less than this height, and that of other 50% is greater than this height.

Example-8. The median of the following data is 525. Find the values of x and y , if the total frequency is 100. Here, CI stands for class interval and Fr for frequency.

CI	0-100	100-200	200-300	300-400	400-500	500-600	600-700	700-800	800-900	900-1000
Fr	2	5	x	12	17	20	y	9	7	4

Solution :

Class intervals	Frequency	Cumulative frequency
0-100	2	2
100-200	5	7
200-300	x	$7+x$
300-400	12	$19+x$
400-500	17	$36+x$
500-600	20	$56+x$
600-700	y	$56+x+y$
700-800	9	$65+x+y$
800-900	7	$72+x+y$
900-1000	4	$76+x+y$

It is given that $n = 100$

So, $76 + x + y = 100$, i.e., $x + y = 24$ (1)

The median is 525, which lies in the class 500 – 600

So, $l = 500$, $f = 20$, $cf = 36 + x$, $h = 100$



Using the formula

$$\text{Median} = l + \frac{\left(\frac{n}{2} - cf\right)}{f} \times h$$
$$525 = 500 + \frac{50 - 36 - x}{20} \times 100$$

$$525 - 500 = (14 - x) \times 5$$

$$25 = 70 - 5x$$

$$5x = 70 - 25 = 45$$

$$\therefore x = 9$$

Therefore, from (1), we get $9 + y = 24$

$$\therefore y = 15$$

Note :

The median of grouped data with unequal class sizes can also be calculated.

14.5 Which value of Central Tendency?

Which measure would be best suited for a particular requirement

The mean is the most frequently used measure of central tendency because it takes into account all the observations, and lies between the extremes, i.e., the largest and the smallest observations of the entire data. It also enables us to compare two or more distributions. For example, by comparing the average (mean) results of students of different schools of a particular examination, we can conclude which school has a better performance.

However, extreme values in the data affect the mean. For example, the mean of classes having frequencies more or less the same is a good representative of the data. But, if one class has frequency, say 2, and the five others have frequency 20, 25, 20, 21, 18, then the mean will certainly not reflect the way the data behaves. So, in such cases, the mean is not a good representative of the data.

In problems where individual observations are not important, especially extreme values, and we wish to find out a 'typical' observation, the median is more appropriate, e.g., finding the typical productivity rate of workers, average wage in a country, etc. These are situations where extreme values may exist. So, rather than the mean, we take the median as a better measure of central tendency.



In situations which require establishing the most frequent value or most popular item, the mode is the best choice, e.g., to find the most popular T.V. programme being watched, the consumer item in greatest demand, the colour of the vehicle used by most of the people, etc.



Exercise - 14.3

1. The following frequency distribution gives the monthly consumption of electricity of 68 consumers of a locality. Find the median, mean and mode of the data and compare them.

Monthly consumption	65-85	85-105	105-125	125-145	145-165	165-185	185-205
Number of consumers	4	5	13	20	14	8	4

2. If the median of 60 observations, given below is 28.5, find the values of x and y .

Class interval	0-10	10-20	20-30	30-40	40-50	50-60
Frequency	5	x	20	15	y	5

3. A life insurance agent found the following data about distribution of ages of 100 policy holders. Calculate the median age. [Policies are given only to persons having age 18 years onwards but less than 60 years.]

Age (in years)	Below 20	Below 25	Below 30	Below 35	Below 40	Below 45	Below 50	Below 55	Below 60
Number of policy holders	2	6	24	45	78	89	92	98	100

4. The lengths of 40 leaves of a plant are measured correct to the nearest millimetre, and the data obtained is represented in the following table. Find the median length of the leaves.

Length (in mm)	118-126	127-135	136-144	145-153	154-162	163-171	172-180
Number of leaves	3	5	9	12	5	4	2

(Hint : The data needs to be converted to continuous classes for finding the median, since the formula assumes continuous classes. The classes then change to 117.5 - 126.5, 126.5 - 135.5, . . . , 171.5 - 180.5.)



5. The following table gives the distribution of the life-time of 400 neon lamps

Life time (in hours)	1500- 2000	2000- 2500	2500- 3000	3000- 3500	3500- 4000	4000- 4500	4500- 5000
Number of lamps	14	56	60	86	74	62	48

Find the median life time of a lamp.

6. 100 surnames were randomly picked up from a local telephone directory and the frequency distribution of the number of letters in the English alphabet in the surnames was obtained as follows

Number of letters	1-4	4-7	7-10	10-13	13-16	16-19
Number of surnames	6	30	40	16	4	4

Determine the median number of letters in the surnames. Find the mean number of letters in the surnames? Also, find the modal size of the surnames.

7. The distribution below gives the weights of 30 students of a class. Find the median weight of the students.

Weight (in kg)	40-45	45-50	50-55	55-60	60-65	65-70	70-75
Number of students	2	3	8	6	6	3	2

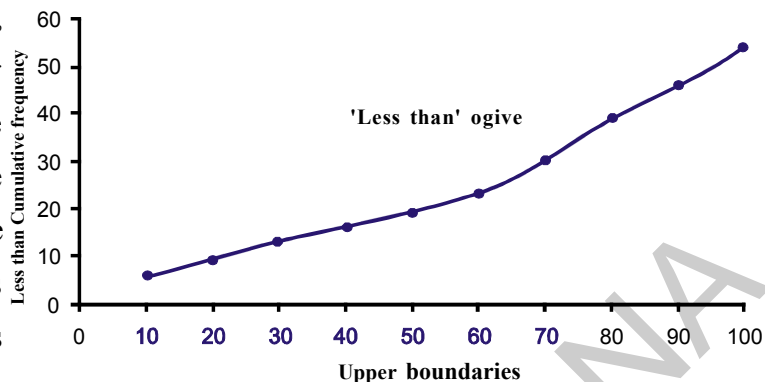
14.6 Graphical Representation of Cumulative Frequency Distribution

As we all know, pictures speak better than words. A graphical representation helps us in understanding given data at a glance. In previous classes, we have represented the data through bar graphs, histograms and frequency polygons. Let us now represent a cumulative frequency distribution graphically.

For example, let us consider the cumulative frequency distribution given in example 6. For drawing ogives, it should be ensured that the class intervals are continuous, because cumulative frequencies are linked with boundaries, but not with limits.



Recall that the values 10, 20, 30, ..., 100 are the upper boundaries of the respective class intervals. To represent the data graphically, we mark the upper boundaries of the class intervals on the horizontal axis (X-axis) and their

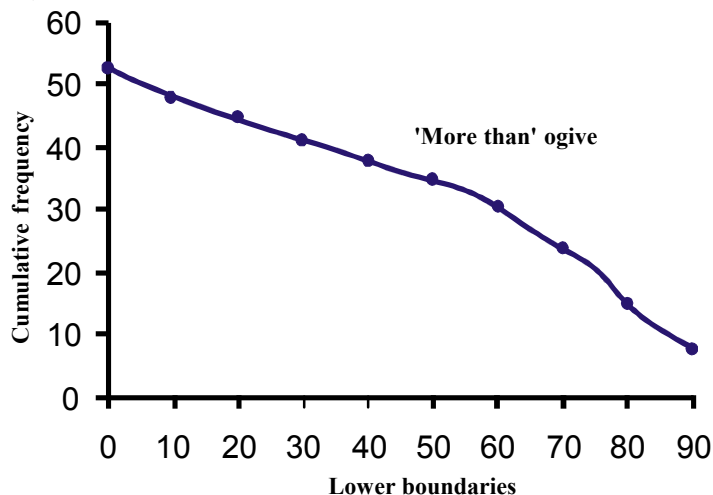


corresponding cumulative frequencies on the vertical axis (Y-axis), choosing a convenient scale. Now plot the points corresponding to the ordered pairs given by (upper boundary, corresponding cumulative frequency), i.e., (10, 5), (20, 8), (30, 12), (40, 15), (50, 18), (60, 22), (70, 29), (80, 38), (90, 45), (100, 53) on a graph paper and join them by a free hand smooth curve. The curve we get is called a cumulative frequency curve, or an ogive (of the less than type).

The term 'ogive is pronounced as 'ojeev' and is derived from the word ogee. An ogee is a shape consisting of a concave arc flowing into a convex arc, so forming an S-shaped curve with vertical ends. In architecture, the ogee shape is one of the characteristics of the 14th and 15th century Gothic styles.

Again we consider the cumulative frequency distribution and draw its ogive (of the more than type).

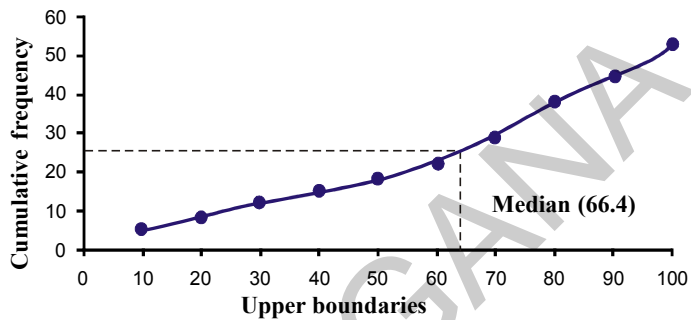
Recall that, here 0, 10, 20, ..., 90 are the lower boundaries of the respective class intervals. To represent 'the more than type' graphically, we plot the lower boundaries on the X-axis and the corresponding cumulative frequencies on the Y-axis. Then we plot the points (lower boundaries, corresponding cumulative frequency), i.e., (0, 53), (10, 48), (20, 45), (30, 41), (40, 38), (50, 35), (60, 31), (70, 24), (80, 15), (90, 8), on a graph paper, and join them by a free hand smooth curve. The curve we get is a cumulative frequency curve, or an ogive (of the more than type).



14.6.1 Obtaining Median from a given curve:

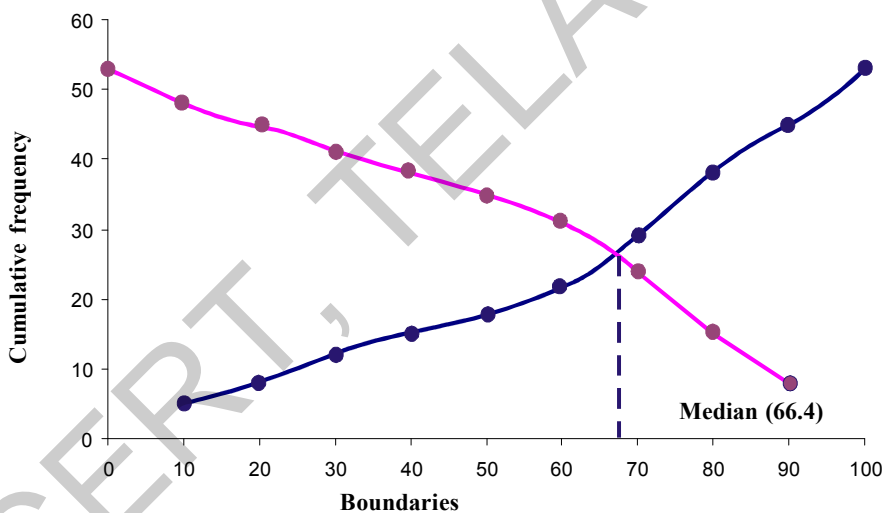
Is it possible to obtain the median from these two cumulative frequency curves . Let us see.

One obvious way is to locate on $\frac{n}{2} = \frac{53}{2} = 26.5$ on the y -axis. From this point, draw a line parallel to the X -axis cutting the curve at a point. From this point, draw a perpendicular to the X -axis. Foot of this perpendicular determines the median of the data.



Another way of obtaining the median :

Draw both ogives (i.e., of the less than type and of the more than type) on the same axis. The two ogives will intersect each other at a point. From this point, if we draw a perpendicular on the x -axis, the point at which it cuts the x -axis gives us the median.



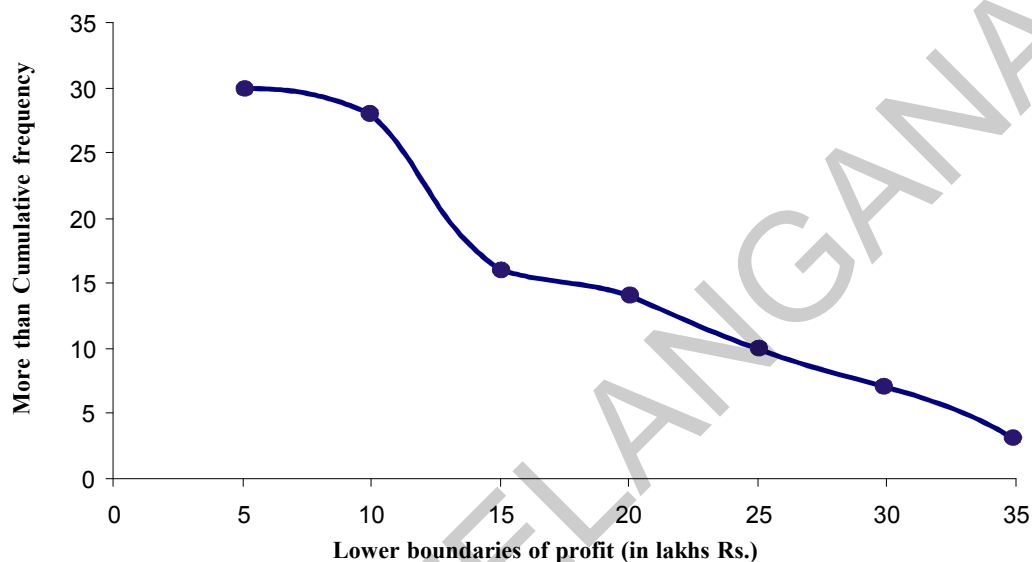
Example-9. The annual profits earned by 30 shops in Sangareddy locality give rise to the following distribution :

Profit (in lakhs)	Number of shops (frequency)
More than or equal to 5	30
More than or equal to 10	28
More than or equal to 15	16
More than or equal to 20	14
More than or equal to 25	10
More than or equal to 30	7
More than or equal to 35	3

Draw both ogives for the data above. Hence obtain the median profit.



Solution : We first draw the coordinate axes, with lower boundaries of the profit along the horizontal axis, and the cumulative frequency along the vertical axes. Then, we plot the points (5, 30), (10, 28), (15, 16), (20, 14), (25, 10), (30, 7) and (35, 3). We join these points with a smooth curve to get the more than ogive, as shown in the figure below-



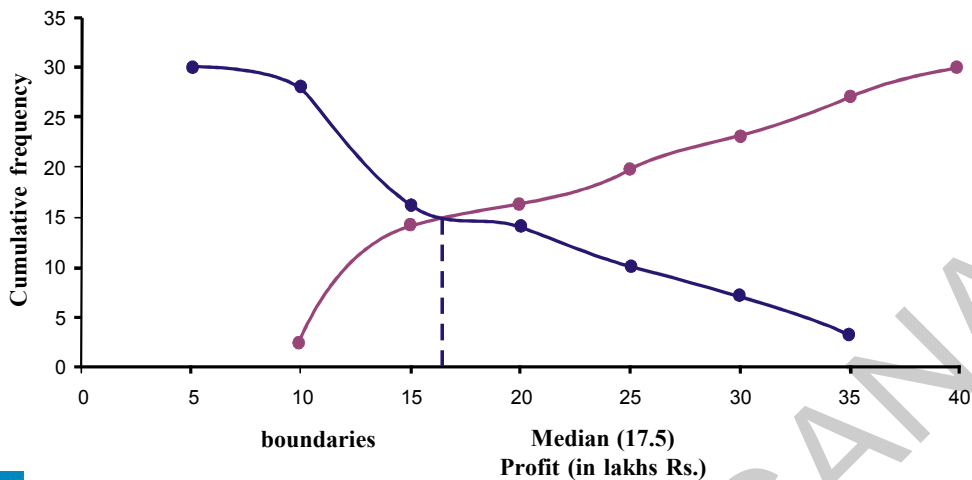
Now, let us obtain the classes, their frequencies and the cumulative frequency from the table above.

Classes	5-10	10-15	15-20	20-25	25-30	30-35	35-40
Number of shops	2	12	2	4	3	4	3
Cumulative frequency	2	14	16	20	23	27	30

Using these values, we plot the points (10, 2), (15, 14), (20, 16), (25, 20), (30, 23), (35, 27), (40, 30) on the same axes as in last figure to get the less than ogive, as shown in figure below.

The abscissa of their point of intersection is nearly 17.5, which is the median. This can also be verified by using the formula. Hence, the median profit (in lakhs) is 17.5.





Exercise - 14.4

1. The following distribution gives the daily income of 50 workers of a factory.

Daily income (in Rupees)	250-300	300-350	350-400	400-450	450-500
Number of workers	12	14	8	6	10

Convert the distribution above to a less than type cumulative frequency distribution, and draw its ogive.

2. During the medical check-up of 35 students of a class, their weights were recorded as follows :

Weight (in kg)	Number of students
Less than 38	0
Less than 40	3
Less than 42	5
Less than 44	9
Less than 46	14
Less than 48	28
Less than 50	32
Less than 52	35

Draw a less than type ogive for the given data. Hence obtain the median weight from the graph and verify the result by using the formula.

3. The following table gives production yield per hectare of wheat of 100 farms of a village.

Production yield (Qui/Hec)	50-55	55-60	60-65	65-70	70-75	75-80
Number of farmers	2	8	12	24	38	16

Change the distribution to a more than type distribution, and draw its ogive.



Suggested Projects

Finding mean - median - mode.

- Applications of daily life situations.
- Collecting information from available sources.
- Finding mean, median and mode for the above collected data.
- Drawing ogive curves and interpreting them if necessary.



What We Have Discussed

In this chapter, you have studied the following points :

1. The mean for grouped data is calculated by :

(i) The direct method : $\bar{x} = \frac{\sum f_i x_i}{\sum f_i}$

(ii) The assumed mean method : $\bar{x} = a + \frac{\sum f_i d_i}{\sum f_i}$

(iii) The step deviation method : $\bar{x} = a + \left(\frac{\sum f_i u_i}{\sum f_i} \right) \times h$

2. The mode for grouped data can be found by using the formula :

$$\text{Mode} = l + \left(\frac{f_1 - f_0}{2f_1 - f_0 - f_2} \right) \times h$$

3. The median for grouped data is formed by using the formula :

$$\text{Median} = l + \left(\frac{\frac{n}{2} - cf}{f} \right) \times h$$

4. In order to find median, class intervals should be continuous.
5. Representing a cumulative frequency distribution graphically as a cumulative frequency curve, or an ogive of the less than type and of the more than type.
6. While drawing ogives, boundaries are taken on X-axis and cumulative frequencies are taken on Y-axis.
7. Scale on both the axes may not be equal.
8. The median of grouped data can be obtained graphically as the x -coordinate of the point of intersection of the two ogives for this data.



Mathematical Modelling

A.I.1 Introduction

On 25th February 2013, the ISRO launcher PSLV C20, placed the satellite SARAL into orbit. The satellite weighs 407 kg. It is at an altitude of 781 km and its orbit is inclined at an angle of 98.5° .

On reading the above information, we may wonder:

- (i) How did the scientists calculate the altitude as 781 km. Did they go to space and measure it?
- (ii) How did they conclude that the angle of orbit is 98.5° without actually measuring?

Some more examples are there in our daily life where we wonder how the scientists and mathematicians could possibly have estimated these results. Observe these examples:

- (i) The temperature at the surface of the sun is about $6,000^\circ\text{C}$.
- (ii) The human heart purifies 5 to 6 liters of blood in the body every minute.
- (iii) We know that the distance between the sun and the earth is 149, 000,000 km.

In the above examples, we know that no one went to the sun to measure the temperature or the distance from earth. Nor can we take the heart out of the body and measure the blood it pumps. How did they give accurate answers to this type of questions. The way we answer these and other similar questions is through mathematical modelling.

Mathematical modelling is used not only by scientists but also by us. For example, we might want to know how much money we will get after one year if we invest ₹100 at 10% simple interest. Or we might want to know how many litres of paint is needed to whitewash a room. Even these problems are solved by mathematical modelling.



Think and Discuss

Discuss with your friends some more examples in real life where we cannot directly measure and must use mathematical modelling.



A.I.2 Mathematical Models

Do you remember the formula to calculate the area of a triangle?

$$\text{Area of Triangle} = \frac{1}{2} \times \text{base} \times \text{height}.$$

Similarly, simple interest calculation uses the formula $I = \frac{PTR}{100}$. This formula or equation is a relation between the Interest (I); Principle (P); Time (T); and Rate of Interest (R).

These formulae are examples of mathematical models.

Some more examples for mathematical models.

(i) $\text{Speed (S)} = \frac{\text{Distance}}{\text{time}} = \frac{d}{t}$

(ii) In compound interest sum $(A) = P \left(1 + \frac{r}{100} \right)^n$

Where P = Principle

r = rate of interest

n = number of times interest is to be calculated.



So, Mathematical model is nothing but a mathematical description or relation that describes some real life situation.



Do This

Write some more mathematical models which you have learnt in previous classes.

A.I.3 Mathematical Modelling

We often face problems in our day to day life. To solve them, we try to write it as an equivalent mathematical problem and find its solution. Next we interpret the solution and check to what extent the solution is valid. This process of constructing a mathematical model and using it to find the answer is known as mathematical modelling.



Now let us observe some more examples related to mathematical modelling.

Example-1. Vani wants to buy a washing machine that costs ₹19,000 but she has only ₹15,000. So she decides to invest her money at 8% simple interest per year. After how many years will she be able to buy the washing machine ?

Solution:

Step 1 : (Understanding the problem): In this stage, we define the real problem. Here, we are given the principle, the rate of simple interest and we want to find out the number of years after which the amount ₹15,000 will become Rs. 19000.

Step 2 : (Mathematical description and formulation) In this step, we describe, in mathematical terms, the different aspects of the problem. We define variables, write equations or inequalities and gather data if required.

Here, we use the formula for simple interest which is

$$I = \frac{PTR}{100} \text{ (Model). Where}$$

P = Principle, T = number of years, R = rate of interest, I = Interest

We need to find time $T = \frac{100I}{RP}$

Step 3: (Solving the mathematical problem) In this step, we solve the problem using the formula which we have developed in step 2.

We know that Vani already has ₹15,000 which is the principal, P

The final amount is ₹19000 so she needs an extra (19000-15000) = ₹4000. This will come from the interest, I.

$$P = ₹15,000, \text{ Rate} = 8\%, \text{ then } I = 4000; T = \frac{100 \times 4000}{15000 \times 8} = \frac{4000}{1200}$$

$$T = 3\frac{4}{12} = 3\frac{1}{3} \text{ years}$$

or **Step4 : (Interpreting the solution):** The solution obtained in the previous step is interpreted here.

Here $T = 3\frac{1}{3}$. This means three and one third of a year or three years and 4 months.

So, Vani can buy a washing machine after 3 year 4 months



Step5 : (Validating the model): We can't always accept a model that gives us an answer that does not match the reality. The process of checking and modifying the mathematical model, if necessary, is validation.

In the given example, we are assuming that the rate of interest will not change. If the rate changes then our model $\frac{PTR}{100}$ will not work. We are also assuming that the price of the washing machine will remain Rs. 19,000.

Let us take another example.

Example-2. In Lokeshwaram High school, 50 children in the 10th class and their Maths teacher want to go on tour from Lokeshwaram to Hyderabad by vehicles. A jeep can hold six persons not including the driver. How many jeeps they need to hire?

Step 1 : We want to find the number of jeeps needed to carry 51 persons, given that each jeep can seat 6 persons besides the driver.

Step 2 : Number of vehicles = (Number of persons) / (Persons that can be seated in one jeep)

Step 3 : Number of vehicles = $51/6 = 8.5$

Step 4 : Interpretation

We know that it is not possible to have 8.5 vehicles. So, the number of vehicles needed has to be the nearest whole number which is 9.

\therefore Number of vehicles need is 9.

Step 5 : Validation

While modelling, we have assumed that lean and fat children occupy same space. Otherwise this model will not useful to us.



Do This

1. Select any verbal problem from your textbook, make a mathematical model for the selected problem and solve it.
2. Suppose a car starts from a place A and travels at a speed of 40 Km/h towards another place B. At the same time another car starts from B and travels towards A at a speed of 30 Km/h. If the distance between A and B is 100 km; after how much time will the cars meet?

Make a mathematical model for the problem given above and solve it.



So far, we have made mathematical models for simple word problems. Let us take a real life example and model it.

Example-3. In the year 2000, 191 member countries of the U.N. signed a declaration to promote gender equality. One indicator for deciding whether this goal has been achieved is the ratio of girls to boys in primary, secondary education. India also signed the declaration. The data for the percentage of girls in India who are enrolled in primary schools is given in Table

Table A.I.1

Year	Enrolment (in %)
1991 – 92	41.9
1992 – 93	42.6
1993 – 94	42.7
1994 – 95	42.9
1995 – 96	43.1
1996 – 97	43.2
1997 -98	43.5
1998 – 99	43.5
1999 – 2000	43.6
2000 – 01	43.7
2001 - 02	44.1

Using this data, mathematically describe the rate at which the proportion of girls enrolled in primary schools grew. Also, estimate the year by which the enrolment of girls will reach 50%.

Solution :

Step 1 : Formulation Let us first convert the problem into a mathematical problem.

Table A.I.1 gives the enrolment for the years 1991 – 92, 1992- 93 etc. Since the students join at the beginning of an academic year, we can take the years as 1991, 1992 etc. Let us assume that the percentage of girls who join primary schools will continue to grow at the same rate as the rate in Table A.I.1. So, the number of years is important, not the specific years. (To give a similar situation, when we find the simple interest for say, ₹ 15000 at the rate 8% for three years, it does not matter whether the three – year period is from 1999 to 2002 or from 2001 to 2004. What is important is the interest rate in the years being considered)



Here also, we will see how the enrolment grows after 1991 by comparing the number of years that has passed after 1991 and the enrolment. Let us take 1991 as the 0th year, and write 1 for 1992 since 1 year has passed in 1992 after 1991. Similarly we will write 2 for 1993, 3 for 1994 etc. So, Table A.I.1 will now look like as follows.

Table A.I.2

Year	Enrolment (in percentage)
0	41.9
1	42.6
2	42.7
3	42.9
4	43.1
5	43.2
6	43.5
7	43.5
8	43.6
9	43.7
10	44.1

The increase in enrolment is given in the following table A.I.3.

Table A.I.3

Year	Enrolment (in%)	Increase
0	41.9	0
1	42.6	0.7
2	42.7	0.1
3	42.9	0.2
4	43.1	0.2
5	43.2	0.1
6	43.5	0.3
7	43.5	0
8	43.6	0.1
9	43.7	0.1
10	44.1	0.4



At the end of the first year period from 1991 to 1992, the enrolment has increased by 0.7% from 41.9% to 42.6%. At the end of the second year, this has increased by 0.1% from 42.6% to 42.7%. From the table above, we cannot find a definite relationship between the number of years and percentage. But the increase is fairly steady. Only in the first year and in the 10th year there is a jump.

The mean of these values is

$$\frac{0.7 + 0.1 + 0.2 + 0.2 + 0.1 + 0.3 + 0 + 0.1 + 0.1 + 0.4}{10} = 0.22 \quad \dots (1)$$

Let us assume that the enrolment steadily increases at the rate of 0.22 percent.

Step 2 : (Mathematical Description)

We have assumed that the enrolment increases steadily at the rate of 0.22% per year.

So, the Enrolment Percentage (EP) in the first year = $41.9 + 0.22$

EP in the second year = $41.9 + 0.22 + 0.22 = 41.9 + 2 \times 0.22$

EP in the third year = $41.9 + 0.22 + 0.22 + 0.22 = 41.9 + 3 \times 0.22$

So, the enrolment percentage in the n^{th} year = $41.9 + 0.22n$, for $n \geq 1$ (2)

Now, we also have to find the number of years by which the enrolment will reach 50%.

So, we have to find the value of n from this equation

$$50 = 41.9 + 0.22n$$

Step 3 : Solution : Solving (2) for n , we get

$$n = \frac{50 - 41.9}{0.22} = \frac{8.1}{0.22} = 36.8$$

Step 4 : (Interpretation) : Since the number of years is an integral value, we will take the next higher integer, 37. So, the enrolment percentage will reach 50% in $1991 + 37 = 2028$.

Step 5 : (Validation) Since we are dealing with a real life situation, we have to see to what extent this value matches the real situation.

Let us check Formula (2) is in agreement with the reality. Let us find the values for the years we already know, using Formula (2), and compare it with the known values by finding the difference. The values are given in Table A.I.4.



Table A.I.4

Year	Enrolment (in %)	Values given by (2) (in %)	Difference (in %)
0	41.9	41.90	0
1	42.6	42.12	0.48
2	42.7	42.34	0.36
3	42.9	42.56	0.34
4	43.1	42.78	0.32
5	43.2	43.00	0.20
6	43.5	43.22	0.28
7	43.5	43.44	0.06
8	43.6	43.66	-0.06
9	43.7	43.88	-0.18
10	44.1	44.10	0.00

As you can see, some of the values given by Formula (2) are less than the actual values by about 0.3% or even by 0.5%. This can give rise to a difference of about 3 to 5 years since the increase per year is actually 1% to 2%. We may decide that this much of a difference is acceptable and stop here. In this case, (2) is our mathematical model.

Suppose we decide that this error is quite large, and we have to improve this model. Then, we have to go back to Step 2, and change the equation.

Let us do so.

Step 1 : Reformulation : We still assume that the values increase steadily by 0.22%, but we will now introduce a correction factor to reduce the error, For this, we find the mean of all the errors. This is

$$\frac{0 + 0.48 + 0.36 + 0.34 + 0.32 + 0.2 + 0.28 + 0.06 - 0.06 - 0.18 + 0}{10} = 0.18$$

We take the mean of the errors, and correct our formula by this value.

Revised Mathematical Description : Let us now add the mean of the errors to our formula for enrolment percentage given in (2). So, our corrected formula is :



Enrolment percentage in the nth year

$$= 41.9 + 0.22n + 0.18 = 42.08 + 0.22n, \text{ for } n \geq 1 \quad \dots (3)$$

We will also modify Equation (2) appropriately. The new equation for n is :

$$50 = 42.08 + 0.22n \quad \dots (4)$$

Altered Solution : Solving Equation (4) for n, we get

$$n = \frac{50 - 42.08}{0.22} = \frac{7.92}{0.22} = 36$$

Interpretation : Since $n = 36$, the enrolment of girls in primary schools will reach 50% in the year $1991 + 36 = 2027$.

Validation : Once again, let us compare the values got by using Formula (4) with the actual values. Table A.I.5 gives the comparison.

Table A.I.5

Year	Enrolment (in %)	Values given by (2)	Difference between Values	Values given by (4)	Difference between values
0	41.9	41.90	0	41.9	0
1	42.6	42.12	0.48	42.3	0.3
2	42.7	42.34	0.36	42.52	0.18
3	42.9	42.56	0.34	42.74	0.16
4	43.1	42.78	0.32	42.96	0.14
5	43.2	43.00	0.20	43.18	0.02
6	43.5	43.22	0.28	43.4	0.1
7	43.5	43.44	0.06	43.62	-0.12
8	43.6	43.66	-0.06	43.84	-0.24
9	43.7	43.88	-0.18	44.06	-0.36
10	44.1	44.10	0.00	44.28	-0.18

As you can see, many of the values that (4) gives are closer to the actual value than the values that (2) gives. The mean of the errors is 0 in this case.



A.I.4 Advantages of Mathematics Modelling

1. The aim of mathematical modelling is to get some useful information about a real world problem by converting it into mathematical problem. This is especially useful when it is not possible or very expensive to get information by other means such as direct observation or by conducting experiments.

For example, suppose we want to study the corrosive effect of the discharge of the Mathura refinery on the Taj Mahal. We would not like to carry out experiments on the Taj Mahal directly because that would damage a valuable monument. Here mathematical modelling can be of great use.

2. Forecasting is very important in many types of organizations, since predictions of future events have to be incorporated into the decision – making process.

For example

- (i) In marketing departments, reliable forecasts of demand help in planning of the sale strategies
 - (ii) A school board needs to be able to forecast the increase in the number of school going children in various districts so as to decide where and when to start new schools.
3. Often we need to estimate large values like trees in a forest; fishes in a lake; estimation of votes polled etc.

Some more examples where we use mathematical modelling are:

- (i) Estimating future population for certain number of years
- (ii) Predicting the arrival of Monsoon
- (iii) Estimating the literacy rate in coming years
- (iv) Estimating number of leaves in a tree
- (v) Finding the depth of oceans

A.I.5 Limitations of Mathematical modelling

Is mathematical modelling the answer to all our problems?

Certainly not; it has its limitations. Thus, we should keep in mind that a model is only a simplification of a real world problem, and the two are not same. It is some thing like the difference between a map that gives the physical features of a country, and the country itself. We can find the height of a place above the sea level from this map, but we cannot find the characteristics of the people from it. So, we should use a model only for the purpose it is supposed to serve, remembering all the factors we have neglected while constructing it. We should apply the model only within the limits where it is applicable.



A.I.6 To What Extent We Should Try To Improve Our Model?

To improve a model we need to take into account several additional factors. When we do this we add more variables to our mathematical equations. The equations becomes complicated and the model is difficult to use. A model must be simple enough to use yet accurate; i.e the closer it is to reality the better the model is.



Try This

A problem dating back to the early 13th century, posed by Leonardo Fibonacci, asks how many rabbits you would have in one year if you started with just two and let all of them reproduce. Assume that a pair of rabbits produces a pair of offspring each month and that each pair of rabbits produces their first offspring at the age of 2 months. Month by month, the number of pairs of rabbits is given by the sum of the rabbits in the two preceding months, except for the 0th and the 1st months.

The table below shows how the rabbit population keeps increasing every month.

Month	Pairs of Rabbits
0	1
1	1
2	2
3	3
4	5
5	8
6	13
7	21
8	34
9	55
10	89
11	144
12	233
13	377
14	610
15	987
16	1597



After one year, we have 233 pairs. After just 16 months, we have nearly 1600 pairs of rabbits.

Clearly state the problem and the different stages of mathematical modelling in this situation.



We will finish this chapter by looking at some interesting examples.

Example-4. (Rolling of a pair of dice) : Deekshitha and Ashish are playing with dice. Then Ashish said that, if she correctly guess the sum of numbers that show up on the dice, he would give a prize for every answer to her. What numbers would be the best guess for Deekshitha.

Solution :

Step 1 (Understanding the problem) : You need to know a few numbers which have higher chances of showing up.

Step 2 (Mathematical description) : In mathematical terms, the problem translates to finding out the probabilities of the various possible sums of numbers that the dice could show.

We can model the situation very simply by representing a roll of the dice as a random choice of one of the following thirty six pairs of numbers.

(1, 1)	(1, 2)	(1, 3)	(1, 4)	(1, 5)	(1, 6)
(2, 1)	(2, 2)	(2, 3)	(2, 4)	(2, 5)	(2, 6)
(3, 1)	(3, 2)	(3, 3)	(3, 4)	(3, 5)	(3, 6)
(4, 1)	(4, 2)	(4, 3)	(4, 4)	(4, 5)	(4, 6)
(5, 1)	(5, 2)	(5, 3)	(5, 4)	(5, 5)	(5, 6)
(6, 1)	(6, 2)	(6, 3)	(6, 4)	(6, 5)	(6, 6)

The first number in each pair represents the number showing on the first dice, and the second number is the number showing on the second dice.

Step 3 (Solving the mathematical problem) : Summing the numbers in each pair above, we find that possible sums are 2, 3, 4, 5, 6, 7, 8, 9, 10, 11 and 12. We have to find the probability for each of them, assuming all 36 pairs are equally likely.

We do this in the following table.

Sum	2	3	4	5	6	7	8	9	10	11	12
Probability	$\frac{1}{36}$	$\frac{2}{36}$	$\frac{3}{36}$	$\frac{4}{36}$	$\frac{5}{36}$	$\frac{6}{36}$	$\frac{5}{36}$	$\frac{4}{36}$	$\frac{3}{36}$	$\frac{2}{36}$	$\frac{1}{36}$

Observe that the chance of getting a sum of a seven is $\frac{1}{6}$, which is larger than the chances of getting other numbers as sums.



Step 4 (Interpreting the solution) : Since the probability of getting the sum 7 is the highest, you should repeatedly guess the number seven.

Step 5 (Validating the model) : Toss a pair of dice a large number of times and prepare a relative frequency table. Compare the relative frequencies with the corresponding probabilities. If these are not close, then possibly the dice are biased. Then, we could obtain data to evaluate the number towards which the bias is.

Before going to the next try this exercise, we need some background information.

Not having the money you want when you need it, is a common experience for many people. Whether it is having enough money for buying essentials for daily living, or for buying comforts, we always require money. To enable the customers with limited funds to purchase goods like scooters, refrigerators, televisions, cars, etc., a scheme known as an instalment scheme (or plan) is introduced by traders.

Sometimes a trader introduces an instalment scheme as a marketing strategy to allow customers to purchase these articles. Under the instalment scheme, the customer is not required to make full payment of the article at the time of buying it. She/he is allowed to pay a part of it at the time of purchase and the rest can be paid in instalments, which could be monthly, quarterly, half-yearly, or even yearly. Of course, the buyer will have to pay more in the instalment plan, because the seller is going to charge some interest on account of the payment made at a later date (called deferred payment).

There are some frequently used terms related to this concept. You may be familiar with them. For example, the cost price of an article is the amount which a customer has to pay as full payment of the article at the time it is purchased. Cash down payment is the amount which a customer has to pay as part payment of the price of an article at the time of purchase.

Now, try to solve the problem given below by using mathematical modelling.



Try This

Ravi wants to buy a bicycle. He goes to the market and finds that the bicycle of his choice costs ₹2,400. He has only ₹1,400 with him. To help, the shopkeeper offers to help him. He says that Ravi can make a down payment of ₹1400 and pay the rest in monthly instalments of ₹550 each. Ravi can either take the shopkeeper's offer or go to a bank and take a loan at 12% per annum simple interest. From these two opportunities which is the best one to Ravi. Help him.



Answers

Exercise - 1.1

1. (i) 90 (ii) 196 (iii) 127

Exercise - 1.2

1. (i) $2^2 \times 5 \times 7$ (ii) $2^2 \times 3 \times 13$ (iii) $3^2 \times 5^2 \times 17$
(iv) $5 \times 7 \times 11 \times 13$ (v) $17 \times 19 \times 23$
2. (i) 420, 3 (ii) 1139, 1 (iii) 1800, 1
(iv) 216, 36 (v) 22338, 9
6. 6

Exercise - 1.3

1. (i) 0.375, Terminating (ii) 0.5725, Terminating
(iii) 4.2, Terminating
(iv) $0.\overline{18}$, Non-terminating, repeating
(v) 0.064, Terminating
2. (i) Terminating (ii) Non-terminating, repeating
(iii) Non-terminating, repeating (iv) Terminating
(v) Non-terminating (vi) Terminating
(vii) Non-terminating (viii) Terminating
(ix) Terminating (x) Non-terminating, repeating
3. (i) 0.52 (ii) 0.9375 (iii) 0.115 (iv) 32.08 (v) 1.3
4. (i) Rational, Prime factors of q will be either 2 or 5 or both only
(ii) Not rational
(iii) Rational, Prime factors of q will also have a factor other than 2 or 5.

Exercise - 1.5

1. (i) $\frac{1}{2}$ (ii) $\frac{1}{4}$ (iii) -4 (iv) 0 (v) $\frac{1}{2}$ (vi) 9
(vii) -2 (viii) 3 (ix) 12



2. (i) $\log 10, 1$ (ii) $\log_2 8, 3$ (iii) $\log_{64} 64, 1$ (iv) $\log\left(\frac{9}{8}\right)$
 (v) $\log 45$
3. (i) $x + y$ (ii) $x + y - 1$ (iii) $x + y + 2$ (iv) $3x + 3y + 1$
4. (i) 3 (ii) $7\log 2 - 4\log 5$ (iii) $2\log x + 3\log y + 4\log z$
 (iv) $2\log p + 3\log q - 4\log r$ (v) $\frac{3}{2}\log x - \log y$
6. 7 7. $\frac{1}{3}$ 8. $\frac{\log\left(\frac{3}{2}\right)}{\log 6}$

Exercise - 2.1

1. (i) Set (ii) Not set (iii) Not set
 (iv) Set (v) Set
2. (i) \in (ii) \notin (iii) \notin (iv) \notin
 (v) \in (vi) \in
3. (i) $x \notin A$ (ii) $d \in B$ (iii) $1 \in N$ (iv) $8 \notin P$
4. (i) False (ii) False (iii) True (iv) False
5. (i) $B = \{1, 2, 3, 4, 5\}$
 (ii) $C = \{17, 26, 35, 44, 53, 62, 71, 80\}$
 (iii) $D = \{2, 3, 5\}$
 (iv) $E = \{B, E, T, R\}$
6. (i) $A = \{x : x \text{ is multiple of } 3 \text{ \& less than } 13\}$
 (ii) $B = \{x : x = 2^a, a \in N, a < 6\}$
 (iii) $C = \{x : x = 5^a, a \in N, a < 5\}$
 (iv) $D = \{x : x \text{ is square number and } x \leq 10, x \in N\}$
7. (i) $A = \{51, 52, 53, \dots, 98, 99\}$
 (ii) $B = \{+2, -2\}$
 (iii) $D = \{L, O, Y, A\}$
 (iv) $E = \{1, 3, 9, 19\}$



8. (i) – (c)
 (ii) – (a)
 (iii) (d)
 (iv) (b)

Exercise - 2.2

1. Yes, $A \cap B$ & $B \cap A$ are same
2. $A \cap \phi = \phi$
 $A \cap A = A$
3. $A - B = \{2, 4, 8, 10\}$
 $B - A = \{3, 9, 12, 15\}$
4. $A \cup B = B$
5. $A \cap B = \{\text{even natural number}\}$
 $\{2, 4, 6, \dots\}$
 $A \cap C = \{\text{odd natural numbers}\}$
 $A \cap D = \{2, 3, 5, 7, 11, \dots, 97\}$
 $B \cap C = \phi$
 $B \cap D = \{\text{even natural number}\}$
 $C \cap D = \{3, 5, 7, 11, \dots\}$
6. (i) $A - B = \{3, 6, 9, 15, 18, 21\}$
 (ii) $A - C = \{3, 9, 15, 18, 21\}$
 (iii) $A - D = \{3, 6, 9, 12, 18, 21\}$
 (iv) $B - A = \{4, 8, 16, 20\}$
 (v) $C - A = \{2, 4, 8, 10, 14, 16\}$
 (vi) $D - A = \{5, 10, 20\}$
 (vii) $B - C = \{20\}$
 (viii) $B - D = \{4, 8, 12, 16\}$
 (ix) $C - B = \{2, 6, 10, 14\}$
 (x) $D - B = \{5, 10, 15\}$



7. (i) False, because they have common element '3'
 (ii) False, because the two sets have a common element a'
 (iii) True, because no common elements for the sets.
 (iv) True, because no common elements for the sets.

Exercise - 2.3

1. Yes, equal sets
2. (i) Equal (=) (ii) Not equal (\neq) (iii) Equal (=) (iv) Not equal (\neq)
 (v) Not equal (\neq) (vi) Not equal (\neq) (vii) Not equal (\neq)
3. (i) $A = B$ (ii) $A \neq B$ (iii) $A \neq B$ (iv) $A \neq B$
4. (i) $\{1, 2, 3, \dots, 10\} \neq \{2, 3, 4, \dots, 9\}$
 (ii) $x = 2x + 1$ means x is odd
 (iii) x is multiple of 15. So 5 does not exist
 (iv) x is prime number but 9 is not a prime number
5. (i) $\{p\}, \{q\}, \{p, q\}, \{\phi\}$
 (ii) $\{x\}, \{y\}, \{z\}, \{x, y\}, \{y, z\}, \{z, x\}, \{x, y, z\}, \phi$
 (iii) $\{a\}, \{b\}, \{c\}, \{d\}, \{a, b\}, \{b, c\}, \{c, d\}, \{a, c\}, \{a, d\}, \{b, d\}, \{a, b, c\},$
 $\{b, c, d\}, \{a, b, d\}, \{a, c, d\}, \{a, b, c, d\}, \phi$
 (iv) $\phi, \{1\}, \{4\}, \{9\}, \{16\}, \{1, 4\}, \{1, 9\}, \{1, 16\}, \{4, 9\}, \{4, 16\}, \{9, 16\},$
 $\{1, 4, 9\}, \{1, 9, 16\}, \{4, 9, 16\}, \{1, 4, 16\}, \{1, 4, 9, 16\}$
 (v) $\phi, \{10\}, \{100\}, \{1000\}, \{10, 100\}, \{100, 1000\}, \{10, 1000\},$
 $\{10, 100, 1000\}$

Exercise - 2.4

1. (i) Not empty (ii) Empty (iii) Empty
 (iv) Empty (v) Not empty
2. (i) Finite (ii) Finite (iii) Finite
3. (i) Finite (ii) Infinite (iii) Infinite (iv) Infinite



Exercise - 3.1

- (a) (i) -6 (ii) 7 (iii) -6
- (i) False ($\sqrt{2}$ is coefficient of x^2 not a degree)
(ii) False (Coefficient of x^2 is -4)
(iii) True (For any constant term, degree is zero)
(iv) False (It is not a polynomial at all)
(v) False (Degree of a polynomial is not related with number of terms)
- $p(1) = 0$, $p(-1) = -2$, $p(0) = -1$, $p(2) = 7$, $p(-2) = -9$
- Yes, -2 and -2 are zeroes of the polynomial $x^4 - 16$
- Yes, 3 and -2 are zeroes of the polynomial $x^2 - x - 6$

Exercise - 3.2

- (i) No zeroes (ii) 1 (iii) 3
(iv) 2 (v) 4 (vi) 3
- (i) 0 (ii) $-2, -3$ (iii) $-2, -3$ (iv) $-2, 2, \pm\sqrt{-4}$
- (i) $4, -3$ (ii) $3, 3$ (iii) No zeroes
(iv) $-4, 1$ (v) $-1, 1$
- $p\left(\frac{1}{4}\right) = 0$ and $p(-1) = 0$

Exercise - 3.3

- (i) $4, -2$ (ii) $\frac{1}{2}, \frac{1}{2}$ (iii) $\frac{3}{2}, \frac{-1}{3}$
(iv) $0, -2$ (v) $\sqrt{15}, -\sqrt{15}$ (vi) $-1, \frac{4}{3}$
- (i) $4x^2 - x - 4$ (ii) $3x^2 - 3\sqrt{2}x + 1$ (iii) $x^2 + \sqrt{5}$
(iv) $x^2 - x + 1$ (v) $4x^2 + x + 1$ (vi) $x^2 - 4x + 1$
- (i) $x^2 - x - 2$ (ii) $x^2 - 3$ (iii) $4x^2 + 3x - 1$
(iv) $4x^2 - 8x + 3$
- $-1, +1$ and 3 are zeros of the given polynomial.



Exercise - 3.4

- Quotient = $x - 3$ and remainder = $7x - 9$
 - Quotient = $x^2 + x - 3$ and remainder = 8
 - Quotient = $-x^2 - 2$ and remainder = $-5x + 10$
- Yes
 - Yes
 - No
- $-1, -1$
- $g(x) = x^2 - x + 1$
- $p(x) = 2x^2 - 2x + 14, g(x) = 2, q(x) = x^2 - x + 7, r(x) = 0$
 - $p(x) = x^3 + x^2 + x + 1, g(x) = x^2 - 1, q(x) = x + 1, r(x) = 2x + 2$
 - $p(x) = x^3 + 2x^2 - x + 2, g(x) = x^2 - 1, q(x) = x + 2, r(x) = 4$

Exercise - 4.1

- Intersect at a point
 - Coincident
 - Parallel
- Consistent
 - Inconsistent
 - Consistent
 - Consistent
 - Consistent
 - Inconsistent
 - Inconsistent
 - Consistent
 - Inconsistent
- Number of pants = 1; Number of shirts = 0
- Number of Girls = 7; Number of boys = 3
- Cost of pencil = ₹ 3; Cost of pen = ₹ 5
- Length = 20 m; Width = 16 m
- $6x - 5y - 10 = 0$
 - $4x + 6y - 10 = 0$
 - $6x + 9y - 24 = 0$
- Length = 40 units; Breadth = 30 units
- Number of students = 16; Number of benches = 5



Exercise - 4.2

- Income of Ist person = ₹ 18000; Income of IInd person = ₹ 14000



2. 42 and 24
3. Angles are 81° and 99°
4. (i) Fixed charge = ₹ 40; Charge per km = ₹ 18 (ii) ₹ 490
5. $\frac{7}{9}$
6. 60 km/h; 40 km/h.
7. 31° and 59°
8. 659 and 723
9. 40 ml and 60 ml
10. ₹ 7200 and ₹ 4800

Exercise - 4.3

1. (i) (4, 5) (ii) $\left(\frac{-1}{2}, \frac{1}{4}\right)$ (iii) (4, 9)
 (iv) (1, 2) (v) (3, 2) (vi) $\left(\frac{1}{2}, \frac{1}{3}\right)$
 (vii) (3, 2) (viii) (1, 1)
2. (i) Speed of boat = 8 km/h; Speed of stream = 3 km/h
 (ii) Speed of train = 60 km/h; Speed of car = 80 km/h
 (iii) Number of days by man = 18; Number of days by woman = 36

Exercise - 5.1

1. (i) Yes (ii) Yes (iii) No
 (iv) Yes (v) Yes (vi) No
 (vii) No (viii) Yes
2. (i) $2x^2 + x - 528 = 0$ ($x = \text{Breadth}$)
 (ii) $x^2 + x - 306 = 0$ ($x = \text{Smaller integer}$)
 (iii) $x^2 + 32x - 273 = 0$ ($x = \text{Rohan's Age}$)
 (iv) $x^2 - 8x - 1280 = 0$ ($x = \text{Speed of the train}$)



Exercise - 5.2

1. (i) $-2; 5$ (ii) $-2; \frac{3}{2}$ (iii) $-\sqrt{2}; \frac{-5}{\sqrt{2}}$
(iv) $\frac{1}{4}; \frac{1}{4}$ (v) $\frac{1}{10}; \frac{1}{10}$ (vi) $-6; 2$
(vii) $1, \frac{2}{3}$ (viii) $-1; 3$ (ix) $7, \frac{8}{3}$
2. 13, 14
3. 17, 18; $-17, -18$
4. 5 cm, 12 cm
5. Number of articles = 6; Cost of each article = 15
6. 4 m; 10 m
7. Base = 12 cm; Altitude = 8 cm
8. 15 km, 20 km
9. 20 or 40
10. 9 kmph

Exercise - 5.3

1. (i) $\frac{-1+\sqrt{33}}{4}, \frac{-1-\sqrt{33}}{4}$ (ii) $\frac{-\sqrt{3}}{2}, \frac{-\sqrt{3}}{2}$
(iii) $2, \frac{-3}{5}$ (iv) $-1, -5$
2. (i) $\frac{-1+\sqrt{33}}{4}, \frac{-1-\sqrt{33}}{4}$ (ii) $\frac{-\sqrt{3}}{2}, \frac{-\sqrt{3}}{2}$
(iii) $2, \frac{-3}{5}$ (iv) $-1, -5$
3. (i) $\frac{3-\sqrt{13}}{2}, \frac{3+\sqrt{13}}{2}$ (ii) 1, 2
4. 7 years
5. Maths = 12, English = 18 (or) Maths = 13, English = 17
6. 120 m; 90 m
7. 18, 12; $-18, -12$
8. 40 kmph
9. 15 hours, 25 hours



10. Speed of the passenger train = 33 kmph
Speed of the express train = 44 kmph

11. 18 m; 12 m

12. 3 seconds

13. 13 sides; No



Exercise - 5.4

1. (i) Real roots do not exist
(ii) Equal roots; $\frac{2}{\sqrt{3}}, \frac{2}{\sqrt{3}}$
(iii) Distinct roots; $\frac{3+\sqrt{3}}{2}, \frac{3-\sqrt{3}}{2}$
2. (i) $k = \pm 2\sqrt{6}$ (ii) $k = 6$
3. Yes; 40 m; 20 m
4. No
5. Yes; 20 m; 20 m

Exercise - 6.1

1. (i) AP (ii) Not AP (iii) AP (iv) Not AP
2. (i) 10, 20, 30, 40 (ii) $-2, -2, -2, -2$
(iii) 4, 1, $-2, -5$ (iv) $-1, -\frac{1}{2}, 0, \frac{1}{2}$
(v) $-1.25, -1.5, -1.75, -2$
3. (i) $a_1 = 3; d = -2$ (ii) $a_1 = -5; d = 4$
(iii) $a_1 = \frac{1}{3}; d = \frac{4}{3}$ (iv) $a_1 = 0.6; d = 1.1$
4. (i) Not AP
(ii) AP, next three terms = $4, \frac{9}{2}, 5$
(iii) AP, next three terms = $-9.2, -11.2, -13.2$



- (iv) AP, next three terms = 6, 10, 14
- (v) AP, next three terms = $3 + 4\sqrt{2}$, $3 + 5\sqrt{2}$, $3 + 6\sqrt{2}$
- (vi) Not AP
- (vii) AP, next three terms = -16, -20, -24
- (viii) AP, next three terms = $\frac{-1}{2}$, $\frac{-1}{2}$, $\frac{-1}{2}$
- (ix) Not AP
- (x) AP, next three term = $5a$, $6a$, $7a$
- (xi) Not AP
- (xii) AP, next three terms = $\sqrt{50}$, $\sqrt{72}$, $\sqrt{98}$
- (xiii) Not AP

Exercise - 6.2

1. (i) $a_8 = 28$ (ii) $d = 2$ (iii) $a = 46$
 (iv) $n = 10$ (v) $a_n = 3.5$
2. (i) -77 (ii) 22
3. (i) $a_2 = 14$
 (ii) $a_1 = 18$; $a_3 = 8$
 (iii) $a_2 = \frac{13}{2}$; $a_3 = 8$
 (iv) $a_2 = -2$; $a_3 = 0$; $a_4 = 2$; $a_5 = 4$
 (v) $a_1 = 53$; $a_3 = 23$; $a_4 = 8$; $a_5 = -7$
4. 16th term
5. (i) 34 (ii) 27
6. No 7. 178 8. 5 9. 1
10. 100 11. 128 12. 60 13. 13
14. AP = 4, 10, 16, 15. 158
16. -13, -8, -3 17. 11



Exercise - 6.3

1. (i) 245 (ii) -180 (iii) 5505 (iv) $\frac{33}{20} = 1\frac{13}{20}$
2. (i) $\frac{2093}{2} = 1046\frac{1}{2}$ (ii) 286 (iii) -8930
3. (i) $n = 16, 440$ (ii) $d = \frac{7}{3}, S_{13} = 273$
 (iii) $a = 4, S_{12} = 246$ (iv) $d = -1, a_{10} = 8$
 (v) $n = 5; a_5 = 34$ (vi) $n = 7; a = -8$
 (vii) $a = 4$
4. $n = 38; S_{38} = 6973$
5. 5610
6. n^2
7. (i) 525 (ii) -465
8. $S_1 = 3; S_2 = 4; a_2 = 1; a_3 = -1; a_{10} = -15$
 $a_n = 5 - 2n$
9. 4920 10. 160, 140, 120, 100, 80, 60, 40
11. 234 12. 143 13. 16 14. 370

Exercise - 6.4

1. (i) No (ii) No (iii) Yes
2. (i) 4, 12, 36, ... (ii) $\sqrt{5}, \frac{\sqrt{5}}{5}, \frac{\sqrt{5}}{25}, \dots$
 (iii) 81, -27, 9, ... (iv) $\frac{1}{64}, \frac{1}{32}, \frac{1}{16}, \dots$
3. (i) Yes; 32, 64, 128 (ii) Yes, $\frac{-1}{24}, \frac{1}{48}, \frac{-1}{96}$
 (iii) No (iv) Yes; -54, -162, -486 (v) No
 (vi) Yes; -81, 243, -729 (vii) Yes; $\frac{1}{x^2}, \frac{1}{x^3}, \frac{1}{x^4}, \dots$
 (viii) Yes; -16, $32\sqrt{2}, -128$ (ix) Yes; 0.0004, 0.00004, 0.000004
4. -4



Exercise - 6.5

1. (i) $r = \frac{1}{2}$; $a_n = 3\left(\frac{1}{2}\right)^{n-1}$
 (ii) $r = -3$; $a_n = 2(-3)^{n-1}$
 (iii) $r = 3$; $a_n = (-1)(3)^{n-1}$
 (iv) $r = \frac{2}{5}$; $a_n = 5\left(\frac{2}{5}\right)^{n-1}$
2. $a_{10} = 5^{10}$; $a_n = 5^n$
3. (i) $\frac{1}{3^4}$ (ii) $\frac{-4}{3^4}$
4. (i) 5 (ii) 12 (iii) 7
5. $3 \times 2^{10} = 3072$ 6. $\frac{9}{4}, \frac{3}{2}, 1, \dots$ 7. 5

Exercise - 7.1

1. (i) $2\sqrt{2}$ (ii) $4\sqrt{2}$ (iii) $5\sqrt{2}$ (iv) $2\sqrt{a^2 + b^2}$
2. 39
3. Points are not collinear
4. $AB = BC = \sqrt{37}$; $AC = 2$
5. $AB = BC = CA = 2a$ (vertices of equilateral triangle)
6. $AB = CD = \sqrt{313}$, $BC = AD = \sqrt{104}$, $AC \neq BD$ (vertices of parallelogram)
7. $AB = BC = CD = DA = \sqrt[3]{10}$, $AC \neq BD$ (vertices of a rhombus), 72 Sq. units
8. (i) Square (ii) Rectangle (iii) Parallelogram
9. $(-7, 0)$ 10. 7 or -5
11. 3 or -9 12. $4\sqrt{5}$ units
13. $AB = 5$, $BC = 10$, $AC = 15$, $AB + BC = AC = 15$ (can not form the triangle)
14. $x + 13y - 17 = 0$
15. $AB = BC = CD = DA = 3\sqrt{2}$ $AC = BD = 6$ (vertices of a square)
16. $x - y = 2$

Exercise - 7.2

1. (1, 3) 2. $\left(2, \frac{-5}{3}\right)$ and $\left(0, \frac{-7}{3}\right)$



Exercise - 8.3

1. 1:4 2. $\frac{\sqrt{2}-1}{1}$ 4. 96 cm² 6. 3.5 cm

Exercise - 8.4

8. $6\sqrt{7}$ m 9. 13 m 12. 1:2

Exercise - 9.1

1. (i) One (ii) Secant of a circle (iii) One
(iv) Point of contact (v) Infinite (vi) Two
2. PQ = 12 cm 4. 12 cm

Exercise - 9.2

1. (i) d (ii) a (iii) b (iv) a (v) c
2. 8 cm 4. AB = 15 cm, AC = 9 cm
5. 8 cm each 6. $2\sqrt{5}$ cm 9. Two

Exercise - 9.3

1. (i) 28.5 cm² (ii) 285.5 cm²
2. 88.368 cm² 3. 1254.96 cm² 4. 57 cm²
5. 10.5 cm² 6. 6.125 cm² 7. 102.67 cm²
8. 57 cm²

Exercise - 10.1

1. 5500 cm² 2. 184800 cm² 3. 264 c.c.
4. 1:2 5. 21 7. 21,175 cm³
8. 188.4 m² 9. 37 cm

Exercise - 10.2

1. 103.62 cm² 2. 1156.57 cm² 3. 219.8 mm²
4. 160 cm² 5. ₹ 827.20 6. 2:3:1



7. $x^2 \left(\frac{\pi}{4} + 6 \right)$ sq. units 8. 374 cm^2

Exercise - 10.3

1. 693 kg 2. Height of the cone(h) = 21 cm; Surface area of the toy = 795.08 cm^2
 3. 89.83 cm^3 4. 616 cm^3 5. 309.57 cm^3
 6. 150 7. 523.9 cm^3

Exercise - 10.4

1. 2.74 cm 2. 12 cm 3. 2.5 m
 4. 5 m 5. 10 6. 400
 7. 100 8. 672

Exercise - 11.1

1. $\sin A = \frac{15}{17}$; $\cos A = \frac{8}{17}$; $\tan A = \frac{15}{8}$
 2. $\frac{527}{168}$ 3. $\cos \theta = \frac{7}{25}$; $\tan \theta = \frac{24}{7}$
 4. $\sin A = \frac{5}{13}$; $\tan A = \frac{5}{12}$
 5. $\sin A = \frac{4}{5}$; $\cos A = \frac{3}{5}$
 7. (i) $\frac{49}{64}$ (ii) $\frac{8 + \sqrt{113}}{7}$
 8. (i) 1 (ii) 0

Exercise - 11.2

1. (i) $\sqrt{2}$ (ii) $\frac{\sqrt{3}}{4\sqrt{2}}$ (iii) 1
 (iv) 2 (v) 1
 2. (i) c (ii) d (iii) c
 3. 1 4. Yes



5. $QR = 6\sqrt{3}$ cm; $PR = 12$ cm
 6. $\angle YZX = 60^\circ$; $\angle YXZ = 30^\circ$ 7. Not true

Exercise - 11.3

1. (i) 1 (ii) 0 (iii) 0
 (iv) 1 (v) 1
 3. $A = 36^\circ$ 6. $\cos 15^\circ + \sin 25^\circ$

Exercise - 11.4

1. (i) 2 (ii) 2 (iii) 1
 6. 1 8. 1 9. $\frac{1}{p}$

Exercise - 12.1

1. 15 m 2. $6\sqrt{3}$ m 3. 4 m
 4. 30° 5. 34.64 m 6. $4\sqrt{3}$ m
 7. Length of ladder = 8.32 m; distance between feet of wall and ladder = 4.16 m
 8. $300\sqrt{3}$ m 9. 15 m 10. 7.5 cm^2

Exercise - 12.2

1. Height of the tower = $5\sqrt{3}$ m; Width of the road = 5 m
 2. 32.908 m 3. 1.464 m 4. 19.124 m
 5. 7.608 m 6. 10 m 7. 51.96 feet; 30 feet 8. 6 m
 9. 200 m/sec. 10. 1:3

Exercise - 13.1

1. (i) 1 (ii) 0, Impossible event (iii) 1, Sure event
 (iv) 1 (v) 0, 1
 2. (i) Yes (ii) Yes (iii) Yes (iv) Yes
 3. 0.95 4. (i) 0 (ii) 1
 5. $\frac{1}{13}, \frac{1}{3}, 1, 0$
 6. 0.008 7. (i) $\frac{1}{2}$ (ii) $\frac{1}{2}$ (iii) $\frac{1}{2}$ 8. $\frac{1}{26}$



Exercise - 13.2

1. (i) $\frac{3}{8}$ (ii) $\frac{5}{8}$
2. (i) $\frac{5}{17}$ (ii) $\frac{8}{17}$ (iii) $\frac{13}{17}$
3. (i) $\frac{5}{9}$ (ii) $\frac{17}{18}$
4. $\frac{5}{13}$ 5. (i) $\frac{1}{8}$ (ii) $\frac{1}{2}$ (iii) $\frac{3}{4}$ (iv) 1
6. (i) $\frac{3}{26}$ (ii) $\frac{3}{13}$ (iii) $\frac{1}{26}$
- (iv) $\frac{1}{52}$ (v) $\frac{1}{4}$ (vi) $\frac{1}{52}$
7. (i) $\frac{1}{5}$ (ii) (a) $\frac{1}{4}$ (b) 0
8. $\frac{11}{12}$ 9. (i) $\frac{1}{5}$ (ii) $\frac{15}{19}$
10. (i) $\frac{9}{10}$ (ii) (a) $\frac{1}{10}$ (b) $\frac{1}{5}$
11. $\frac{11}{84}$ 12. (i) $\frac{31}{36}$ (ii) $\frac{5}{36}$
13. (i) $\frac{1}{36}, \frac{2}{36}, \frac{3}{36}, \frac{4}{36}, \frac{5}{36}, \frac{6}{36}, \frac{5}{36}, \frac{4}{36}, \frac{3}{36}, \frac{2}{36}, \frac{1}{36}$ (ii) Yes
14. $\frac{3}{4}$ 15. (i) $\frac{25}{36}$ (ii) $\frac{11}{36}$

Exercise - 14.1

1. 8.1 plants. We have used direct method because numerical values of x_i and f_i are small.
2. ₹ 313 3. $f = 20$ 4. 75.9



- | | | | | | |
|----|---------|----|--------|----|-----------|
| 5. | 22.31 | 6. | ₹ 211 | 7. | 0.099 ppm |
| 8. | 49 days | 9. | 69.43% | | |

Exercise - 14.2

1. Mode = 36.8 years, Mean = 35.37 years, Maximum number of patients admitted in the hospital are of the age 36.8 years (approx.), while on an average the age of a patient admitted to the hospital is 35.37 years.
2. 65.625 hours
3. Modal monthly expenditure = ₹ 1847.83, Mean monthly expenditure = ₹ 2662.5.
4. Mode : 30.6, Mean = 29.2. Most states/U.T. have a student teacher ratio of 30.6 and on an average, this ratio is 29.2.
5. Mode = 4608.7 runs.
6. Mode = 44.7 cars

Exercise - 14.3

1. Median = 137 units, Mean = 137.05 units, Mode = 135.76 units.

The three measures are approximately the same in this case.

2. $x = 8, y = 7$

3. Median age = 35.76 years

4. Median length = 146.75 mm

Draw ogive by plotting the points :
(300, 12), (350, 26), (400, 34),
(450, 40) and (500, 50)

5. Median life = 3406.98 hours

6. Median = 8.05, Mean = 8.32, Modal size = 7.88

7. Median weight = 56.67 kg



Exercise - 14.4

1.

Daily income (in ₹)	Cumulative frequency
Less than 300	12
Less than 350	26
Less than 400	34
Less than 450	40
Less than 500	50

2. Draw the ogive by plotting the points : (38, 0), (40, 3), (42, 5), (44, 9), (46, 14), (48, 28), (50, 32) and (52, 35). Here $\frac{n}{2}=17.5$. Locate the point on the ogive whose ordinate is 17.5. The x -coordinate of this point will be the median.

3.

Lower boundaries	50	55	60	65	70	75
Greater than Cumulative frequency	100	98	90	78	54	16

Now, draw the ogive by plotting the points : (50, 100), (55, 98), (60, 90), (65, 78), (70, 54) and (75, 16).



Note to the Teachers

Dear teachers,

The State Government has decided to revise the curriculum of all the subjects based on State Curriculum Framework (SCF-2011). The framework emphasises that all children must learn and the mathematics learnt at school must be linked to the life and experience of them. The NCF-2005, the position paper on Mathematics of the NCERT and the Govt. emphasise building understanding and developing the capability, exploration and inclination to mathematize experiences. This would become more possible at the secondary level. We have consolidated the basic framework of mathematics in class-IX and now we are at level of completion of secondary level of mathematics. In previous classes, we have encouraged the students for greater abstraction and formal mathematical formulation. We made them to deal with proofs and use mathematical language. It is important to recognise that as we go forward the language in which mathematical arguments and statements- are presented would become even more symbolic and terse. It is therefore important in this class to help children become comfortable and competent in using mathematical ideas. In class-X, we will make all such idea at level of total abstraction.

It would be important to consider all the syllabi from class-VI to X while looking at teaching class X. The nature and extent of abstraction and use of mathematical language is gradually increasing. The program here would also become axiomatic and children must be slowly empowered to deal with that. One of the major difficulties children have in moving forward and learning secondary mathematics is their inability to deal with the axiomatic nature and language of symbols. They need to have an opportunity to learn and develop these perspectives by engaging with, as a team. Peer support in overcoming the difficulties is critical and it would be important to put them in a group to think, discuss and solve problems. When children will learn such things in class-X, it will be helpful for them in future mathematical learning also.

The syllabus is based on the structural approach, laying emphasis on the discovery and understanding of basic mathematical concepts and generalisations. The approach is to encourage participation and discussion in classroom activities.

The syllabus in textbook of class-X Mathematics has been divided broadly into seven areas viz.. i) Number System ii) Algebra iii) Geometry iv) Mensuration v) Statistics vi) Coordinate Geometry and vii) Trigonometry, Teaching of the topics related to these areas will develop the skills such as problem solving, logical thinking, mathematical communication, representing data in various forms, using mathematics as one of the disciplines of study and also in daily life situations.



This text book attempts to enhance this endeavor by giving higher priority and space to opportunities for contemplations. There is a scope for discussion in small groups and activities required for hands on experience in the form of 'Do this' and 'Try this'. Teacher's support is needed in setting the situations in the classroom and also for development of interest in new book.

Exercises in 'Do This' and 'Try This' are given extensively after completion of each concept. The problems which are given under 'Do This' are based on the concept taught and 'Try This' problems are intended to test the skills of generalization of facts, ensuring correctness and questioning. 'Think, Discuss and Write' has given to understand the new concept between students in their own words.

Entire syllabus in class-X Mathematics is divided into 14 chapters with an appendix, so that a child can go through the content well in bit wise to consolidate the logic and enjoy the learning of mathematics. Colourful pictures, diagrams, readable font size will certainly help the children to adopt the contents and care this book as theirs.

Chapter-1 : Real number, we are discussing about the exploration of real numbers in which the brief account of fundamental theorem of arithmetic, rational numbers their decimal expansion and non-terminating recurring rational numbers has given. Here we are giving some more about the irrational numbers. In this chapter, first time we are introducing logarithms in this we are discussing about basic laws of logarithms and their application.

Chapter-2 : Sets, this is entirely a new chapter at the level of secondary students. In old syllabus it was there but here we are introducing it in class X. This chapter is introduced with wide variety of examples which are dealing about the definition of sets, types of set, Venn diagrams, operations of sets, differences between sets. In this chapter we dealt about how to develop a common understanding of sets. How can you make set of any objects?

Chapter-3 : Polynomials, we are discussing about the fact "what are polynomials?" and degree and value of polynomials come under it. This time we look at the graphical representation of linear equations and quadratic equations. Here we are taking care of zeros and coefficients of a polynomial & their relationship. We also start with cubic polynomials and division algorithm of polynomials.

Chapter-4 : Pair of linear equations in two variables, we start the scenario with discussing about finding of unknown quantities and use of two equations together. Solution of pair of linear equations in two variables with the help of graphical and algebraic methods has done. Here we have illustrated so many examples to understand the relation between coefficients and nature of system of equations. Reduction of equation to two variable linear equation has done here.

The problem is framed in such a way to emphasis the correlation between various chapters within the mathematics and other subjects of daily life of human being. This chapter links the ability of finding unknown with every day experience.

Chapter-5 : Quadratic equations, states the meaning of quadratic equation and solution of quadratic equation with the factorizations completion of squares. Nature of roots is defined here with the use of parabola.

Chapter-6 : Progressions, we have introduced this chapter first time on secondary level. In this chapter use are taking about arithmetic progressions and geometric progressions. How the terms progressing arithmetically and geometrically in progressions discussed. The number of terms, n th terms, sum of terms are stated in this chapter.

Chapter-7 : Coordinate geometry, deals with finding the distance between two points on cartesian plane, section formula, centroid of a triangle and tsisectional points of a line. In this, we are also talking about area of the triangle on plane and finding it with the use of 'Heron's formula'. The slope on straight line is also introduced here.



Chapter-8 : In this chapter, the properties of similar triangles and basic proportionality theories are explained. The theorem for similarity of 2 triangles proved mathematically. The methods of proving Pythagoras' theorem and its converse are discussed in detail.

Chapter 9 : In this chapter, tangents and secants were explained with their properties. We also discussed about the segment and area of segment formed by a secant.

Chapter 10 : In this chapter "Mensuration". Finding the surface areas and volumes of combination of solids is discussed.

Chapter 10 & 12 : We are keeping two new chapters (11 & 12) at second level for the first time. The applications of triangles are used with giving relation with the hypotenuse, perpendicular and base. These chapters are the introduction of trigonometry which have very big role in high level studies and also in determination of so many measurements. Applications of trigonometry are also given with brief idea of using triangle.

Chapter-13 : Probability, is little higher level chapter than the last chapter which we have introduced in class IX. Here we are taking about different terms of probability by using some daily life situations.

Chapter-14 : Statistics, deals with importance of statistics, collection of statistical grouped data, illustrative examples for finding mean, median and mode of given grouped data with different methods. The ogives are also illustrated here again. In appendix, mathematical modeling is given there with an idea about the models and their modeling methods.

The success of any course depends not only on the syllabus but also on the teachers and the teaching methods they employ. It is hoped that all teachers are concerned with the improving of mathematics education and they will extend their full cooperation in this endeavour.

The production of good text books does not ensure the quality of education, unless the teachers transact the curriculum in a way as it is discussed in the text book. The involvement and participation of learner in doing the activities and problems with an understanding is ensured.

Students should be made to digest the concepts given in "What we have discussed" completely. Teachers may prepare their own problems related to the concepts besides solving the problems given in the exercises.

So therefore it is hoped that the teachers will bring a paradigm shift in the classroom process from mere solving the problems in the exercises routinely to the conceptual understanding, solving of problems with ingenuity.

Teaching learning strategies and the expected learning outcomes, have been developed class wise and subject-wise based on the syllabus and compiled in the form of a Hand book to guide the teachers and were supplied to all the schools. With the help of this Hand book the teachers are expected to conduct effective teaching learning processes and ensure that all the students attain the expected learning outcomes.

"Good luck for happy teaching"



Syllabus

I. NUMBER SYSTEM (23 PERIODS)

(i) Real numbers (15 periods)

- More about rational and irrational numbers.
- Euclid Division algorithm.
- Fundamental theorem of Arithmetic - Statements.
- Proofs of results - irrationality of $\sqrt{2}, \sqrt{3}$ etc. and decimal expansions of rational numbers in terms of terminating / non-terminating recurring decimals and vice versa.
- Decimals of real numbers (after reviewing lookdone earlier and after illustrating and motivating through examples)
- Introduction of logarithms
- Conversion of a number in exponential form to a logarithmic form
- Properties of logarithms $\log_a a = 1$; $\log_a 1 = 0$
- Laws of logarithms

$$\log xy = \log x + \log y; \log \frac{x}{y} = \log x - \log y; \log x^n = n \log x, a^{\log_a N} = N$$

- Standard base of logarithm and use of logarithms in daily life situations (not meant for examination)

(ii) Sets (8 periods)

- Sets and their representations
- Empty set, finite and infinite sets, universal set
- Equal sets, subsets, subsets of set of real numbers (especially intervals and notations)
- Venn diagrams and cardinality of sets
- Basic set operations - union and intersection of sets
- Disjoint sets, difference of sets

II. ALGEBRA (46 PERIODS)

(i) Polynomials (8 periods)

- Zeroes of a polynomial
- Geometrical meaning of zeroes of linear, quadratic and cubic polynomials using graphs.
- Relationship between zeroes and coefficients of a polynomial.
- Simple problems on division algorithm for polynomials (with integral coefficients)

(ii) Pair of Linear Equations in Two Variables (15 periods)

- Forming a linear equation in two variables through illustrated examples.
- Graphical representation of a pair of linear equations of different possibilities of solutions / in consistency.
- Algebraic conditions for number of solutions
- Solution of pair of linear equations in two variables algebraically - by Substitution, by elimination.
- Simple and daily life problems on equations reducible to linear equations.

(iii) Quadratic Equations (12 periods)

- Standard form of a quadratic equation $ax^2 + bx + c = 0, a \neq 0$.



- Solutions of quadratic equations (only real roots) by factorisation, by completing the square and by using quadratic formula.
- Relationship between discriminant and nature of roots.
- Problems related to day-to-day activities.

(iv) **Progressions (11 periods)**

- Definition of Arithmetic Progression (A.P)
- Finding nth term and sum of first 'n' terms of A.P.
- Geometric Progression (G.P.)
- Find nth term of G.P.

III. GEOMETRY (33 PERIODS)

(i) **Similar Triangles (18 periods)**

- Similar figures difference between congruency and similarity.
- Properties of similar triangles.
- (Prove) If a line is drawn parallel to one side of a triangle to intersect the other two sides in distinct points, the other two sides are divided in the same ratio.
- (Motivate) If a line divides two sides of a triangle in the same ratio, then the line is parallel to the third side.
- (Motivate) If in two triangles, the corresponding angles are equal, their corresponding sides are proportional and the triangles are similar (AAA).
- (Motivate) If the corresponding sides of two triangles are proportional, their corresponding angles are equal and the two triangles are similar (SSS).
- (Motivate) If one angle of a triangle is equal to one angle of another triangle and the sides including these angles are proportional, the two triangles are similar (SAS).
- (Prove) The ratio of the areas of two similar triangles is equal to the ratio of the squares on their corresponding sides.
- (Motivate) If a perpendicular is drawn from the vertex of the right angle to the hypotenuse, the triangles on each side of the perpendicular are similar to the whole triangle and to each other.
- (Prove) In a right triangle, the square on the hypotenuse is equal to the sum of the squares on the other two sides.
- (Prove) In a triangle, if the square on one side is equal to sum of the squares on the other sides, the angles opposite to the first side is a right triangle.
- (Construction) Division of a line segment using Basic proportionality Theorem.
- (Construction) A triangle similar to a given triangle as per given scale factor.

(ii) **Tangents and secants to a circle (15 periods)**

- Difference between tangent and secant to a circle
- Tangents to a circle motivated by chords drawn from points coming closer and closer to the point
- (Prove) The tangent at any point on a circle is perpendicular to the radius through the point contact.
- (Prove) The lengths of tangents drawn from an external point to a circle are equal.
- (Construction) A tangent to a circle through a point given on it.
- (Construction) Pair of tangents to a circle from an external point.
- Segment of a circle made by the secant.
- Finding the area of minor/major segment of a circle.

IV. COORDINATE GEOMETRY(12 PERIODS)

- Review the concepts of coordinate geometry by the graphs of linear equations.
- Distance between two points $P(x_1, y_1)$ and $Q(x_2, y_2)$ is $PQ = \sqrt{(x_2 - x_1)^2 + (y_2 - y_1)^2}$



- Section formula (internal division of a line segment in the ratio $m : n$).
- Area of triangle on coordinate plane.
- Slope of a line joining two points

V. TRIGONOMETRY (23 PERIODS)

(i) Trigonometry (15 periods)

- Trigonometric ratios of an acute angle of a right angled triangle i.e. sine, cosine, tangent, cosecant, secant and cotangent.
- Values of trigonometric ratios of 0° , 30° , 45° , 60° and 90° (with proofs).
- Relationship between the ratios and trigonometric ratios for complementary angles.
- Trigonometric Identities.
(i) $\sin^2 A + \cos^2 A = 1$, (ii) $1 + \tan^2 A = \sec^2 A$, (iii) $\cot^2 A + 1 = \operatorname{cosec}^2 A$

(ii) Applications of Trigonometry (8 periods)

- Angle of elevation, angle of depression.
- Simple and daily life problems on heights and distances
- Problems involving not more than two right triangles and angles of elevation / depression confined to 30° , 45° and 60° .

VI. MENSURATION (10 PERIODS)

(i) Surface Areas and Volumes

- Problems on finding surface area and volumes of combinations of any two of the following i.e. cubes, cuboids, right circular cylinders, cones spheres and hemispheres.
- Problems involving converting one type of metallic solid into another and finding volumes and other mixed problems involving not more than two different solids.

VII. DATA HANDLING (25 PERIODS)

(i) Statistics (15 periods)

- Revision of mean, median and mode of ungrouped (frequency distribution) data.
- Understanding the concept of Arithmetic mean, median and mode for grouped (classified) data.
- Simple problems on finding mean, median and mode for grouped/ungrouped data with different methods.
- Usage and different values of central tendencies through ogives.

(ii) Probability (10 periods)

- Revision of concept and definition of probability.
- Simple problems (day to day life situation) on single events using set notation.
- Concept of complementary events.

APPENDIX

Mathematical Modeling (8 periods)

- Concept of Mathematical modelling
- Discussion of broad stages of modelling-real life situations (Simple interest, Fair installments payments etc.)



Academic Standards - High School

Academic Standards : Academic standards are clear statements about what students must know and be able to do. The following are categories on the basis of which we lay down academic standards.

Areas of Mathematics	Content
1. Problem Solving	<p>Using concepts and procedures to solve mathematical problems like following:</p> <p>a. Kinds of problems :</p> <p>Problems can take various forms- puzzles, word problems, pictorial problems, procedural problems, reading data, tables, graphs etc.</p> <ul style="list-style-type: none">• Reads problems.• Identifies all pieces of information/data.• Separates relevant pieces of information.• Understanding what concept is involved.• Recalling of (synthesis of) concerned procedures, formulae etc.• Selection of procedure.• Solving the problem.• Verification of answers of raiders, problem based theorems. <p>b. Complexity :</p> <p>The complexity of a problem is dependent on-</p> <ul style="list-style-type: none">• Making connections(as defined in the connections section).• Number of steps.• Number of operations.• Context unraveling.• Nature of procedures.
2. Reasoning Proof	<ul style="list-style-type: none">• Reasoning between various steps (involved invariably conjuncture).• Understanding and making mathematical generalizations and conjectures



- Understands and justifies procedures
- Examining logical arguments.
- Understanding the notion of proof
- Uses inductive and deductive logic
- Testing mathematical conjectures

3. Communication

- Writing and reading, expressing mathematical notations (verbal and symbolic forms)

Example : $3+4=7$

$$n_1+n_2 = n_2+n_1$$

Sum of angles in triangle = 180°

- Creating mathematical expressions
- Explaining mathematical ideas in his own words
Eg - Square is a closed figure with four equal sides and four equal angles
- Explaining the procedure
Eg - Adding units digit first while adding the two digit numbers
- Explaining mathematical logic.

4. Connections

- Connecting concepts within a mathematical domain- for example relating adding to multiplication, parts of a whole to a ratio, to division. Patterns and symmetry, measurements and space.
- Making connections with daily life.
- Connecting mathematics to different subjects.
- Connecting concepts of different mathematical domains like data handling and arithmetic or arithmetic and space.
- Connecting concepts to multiple procedures.

5. Visualization & Representation

- Interprets and reads data in a table, number line, pictograph, bar graph, 2-D figures, 3- D figures, pictures.
- Making tables, number line, pictograph, bar graph, pictures.
- Mathematical symbols and figures.



Learning Outcomes

The learner

- generalizes properties of numbers and relations among them studied earlier to evolve results, such as Euclid's division algorithm, Fundamental Theorem of Arithmetic and applies them to solve problems related to real life contexts.
- derives proofs for irrationality of numbers by applying logical reasoning.
- identifies exponential or logarithmic form, derives proofs for properties of logarithms and solves problems using them.
- identifies sets among collections and classify them like finite set, infinite set etc.
- analyses sets by representing them in the form of Venn diagrams.
- develops a relationship between algebraic and graphical methods of finding the zeroes of a polynomial.
- finds solutions of pairs of linear equations in two variables using graphical and different algebraic methods.
- demonstrates strategies of finding roots and determining the nature of roots of a quadratic equation.
- develops strategies to apply the concept of A.P., G.P. to daily life situations.
- derives formulae to establish relations for geometrical shapes in the context of a coordinate plane, such as, finding the distance between two given points, to determine the coordinates of a point between any two given points, to find the area of a triangle, etc.
- works out ways to differentiate between congruent and similar figures.
- establishes properties for similarity of two triangles logically using different geometric criteria established earlier such as, Basic Proportionality Theorem, etc.
- constructs a triangle similar to a given triangle as per a given scale factor.
- examines the steps of geometrical constructions and reason out each step
- derives proofs of theorems related to the tangents of circles
- constructs a pair of tangents from an external point to a circle and justify the procedures.
- examines the steps of geometrical constructions and reason out each step
- determines all trigonometric ratios with respect to a given acute angle (of a right triangle)
- establishes the relation among trigonometric ratios of acute angles
- uses trigonometric ratios in solving problems in daily life contexts like finding heights of different structures or distance from them.
- finds surface areas and volumes of objects in the surroundings by visualising them as a combination of different solids like cylinder and a cone, cylinder and a hemisphere, combination of different cubes, etc.
- demonstrates strategies for finding surface area etc. when a solid is converted from one shape to the other.
- calculates mean, median and mode for different sets of data related with real life contexts.



Textbook - Overview

With this Mathematics book, children would have completed the three years of learning in the elementary classes and one year of secondary class. We hope that Mathematics learning continues for all children in class X also however, there may be some children for whom this would be the last year of school. It is, therefore, important that children finish the secondary level with a sense of confidence to use Mathematics in organizing experience and motivation to continue learning.

Mathematics is essential for everyone and is a part of the compulsory program for school education till the secondary stage. However, at present, Mathematics learning does not instill a feeling of comfort and confidence in children and adults. It is considered to be extremely difficult and only for a few. The fear of Mathematics pervades not just children and teachers but our entire society. In a context where Mathematics is an increasing part of our lives and is important for furthering our learning, this fear has to be removed. The effort in school should be to empower children and make them feel capable of learning and doing Mathematics. They should not only be comfortable with the Mathematics in the classroom but should be able to use it in the wider world by relating concepts and ideas of Mathematics to formulate their understanding of the world.

One of the challenges that Mathematics teaching faces is in the way it is defined. The visualization of Mathematics remains centered around numbers, complicated calculations, algorithms, definitions and memorization of facts, short-cuts and solutions including proofs. Engaging with exploration and new thoughts is discouraged as the common belief is that there can be only one correct way to solve a problem and that Mathematics does not have possibilities of multiple solutions.

Through this book we want to emphasize the need for multiple ways of attempting problems, understanding that Mathematics is about exploring patterns, discovering relationships and building logic. We would like all teachers to engage students in reading the book and help them in formulating and articulating their understanding of different concepts as well as finding a variety of solutions for each problem. The emphasis in this book is also on allowing children to work with each other in groups and make an attempt to solve problems collectively. We want them to talk to each other about Mathematics and create problems based on the concepts that have learnt. We want everybody to recognize that Mathematics is not only about solving problems set by others or learning proofs and methods that are developed by others, but is about exploration and building new arguments. Doing and learning Mathematics is for every person coming up with her own methods and own rules.



Class X is the final year of secondary level students and they have already dealt about the consolidation of initiations. They have already learnt also to understand that Mathematics consists of ideas that are applied in life situations but do not necessarily arise from life. We would also like children to be exposed to the notion of proof and recognize that presenting examples is not equivalent to proof with modeling aspects.

The purpose of Mathematics as we have tried to indicate in the preface as well as in the book has widened to include exploring mathematization of experiences. This means that students can begin to relate the seemingly abstract ideas they learn in the classrooms to their own experiences and organize their experiences using these ideas. This requires them to have opportunity to reflect and express both their new formulations as well as their hesitant attempt on mathematizing events around them. We have always emphasized the importance of language and Mathematics interplay. While we have tried to indicate at many places the opportunity that has to be provided to children to reflect and use language. We would emphasise the need to make more of this possible in the classrooms. We have also tried to keep the language simple and close to the language that the child normally uses. We hope that teachers and those who formulate assessment tasks would recognize the spirit of the book. The book has been developed with wide consultations and I must thank all those who have contributed to its development. The group of authors drawn from different experiences have worked really hard and together as a team. I salute each of them and look forward to comments and suggestions of those who would be users of this book.

- Text Book Development Committee



Text Book Development Committee

Writers

Sri Tata Venkata Rama Kumar

H.M., ZPHS Mulumudi, SPS Nellore

Sri Soma Prasada Babu

PGT. APTWRS Chandrashekarapuram, SPS Nellore

Dr. Poondla Ramesh

Lecturer, Government IASE SPS Nellore

Sri Komanduru Sreedharacharyulu

SA, ZPHS Narsingi, Medak

Sri Kandala Ramaiah

SA, ZPHS Kasimdevpet, Warangal

Sri Ramadugu Lakshmi Narsimha Murthy

SA, ZPHS Thupranpet, Nalgonda

Sri Gottumukkala V.B.S.N. Raju

SA, Mpl. High School, Kaspa, Vizianagaram.

Sri Padala Suresh Kumar

SA,GHS Vijayanagar Colony, Hyderabad.

Sri Peddada D.L.Ganapati Sharma

SA,GHS Zamisthanpur, Manikeshwar Nagar, Hyd.

Sri Nagula Ravi

SA, ZPHS Lokeshwaram, Adilabad

Sri Kakulavaram Rajender Reddy

Co-ordinator, SCERT T.S., Hyderabad.

Sri Sardar Dharmendra Singh

SA, ZPHS Mannur, Adilabad

Chief Editor

Dr. H.K.Dewan

Educational Advisor, Vidya Bhavan Society
Udaipur, Rajasthan

Editors

Prof. V. Shiva Ramaprasad

Retd. Dept. of Mathematics,
Osmania University, Hyderabad

Sri A. Padmanabham (Rtd.)

Head of the Dept. of Mathematics
Maharaneer College,
Peddapuram, East Godavari Dist.

Prof. N.Ch.Pattabhi Ramacharyulu

Retd., National Institute of Technology,
Warangal

Dr. G.S.N. Murthy (Rtd.)

Reader in Mathematics
Rajah R.S.R.K.Ranga Rao College,
Bobbili, Vizianagaram Dist. (A.P.)

Co-Ordinators

Sri Kakulavaram Rajender Reddy

Co-ordinator, SCERT T.S., Hyderabad.

Sri K. Narayan Reddy

Lecturer, SCERT T.S., Hyderabad

Academic Support Group Members

Sri Hanif Paliwal

Vidya Bhawan Education Resource Centre, Udaipur

Ms. Preeti Mishra

Vidya Bhawan Education Resource Centre, Udaipur

Mrs. Snehbala Joshi

Vidya Bhawan Education Resource Centre, Udaipur

Ms. Tanya Saxena

Vidya Bhawan Education Resource Centre, Udaipur

Ms. M.Archana

Department of Mathematics and Statistics, University of Hyderabad

Illustrations and Design Team

Sri. Prashant Soni

Illustrator, Vidya Bhawan Education Resource Centre, Udaipur

Sri S. M. Ikram

DTP Operator,
Vidya Bhawan Education Resource Centre, Udaipur

Sri Bhawani Shanker

DTP Operator,
Vidya Bhawan Education Resource Centre, Udaipur

Sri Sunkara Koteswara Rao

DTP Operator,
Pavan Graphics, Vignapuricolony, Vidyanagar, Hyderabad.

Smt. Sunkara Sunitha

DTP Operator,
Pavan Graphics, Vignapuricolony, Vidyanagar, Hyderabad.

Sri Kannaiah Dara, DPO,
SCERT, Telangana, Hyderabad.

Cover Page Designing

Sri. K. Sudhakara Chary, HM, UPS Neelikutthy, Mdl.Maripeda, Dist. Warangal



Textbook Development & Publishing Committee

- Chief Production Officer : **Sri. G. Gopal Reddy,**
Director, SCERT, Hyderabad.
- Executive Chief Organiser : **Sri. B. Sudhakar,**
Director, Govt. Text Book Press, Hyderabad.
- Organising Incharge : **Dr. Nannuru Upender Reddy,**
Prof. & Head, Curriculum & Text Book Department,
SCERT, Hyderabad.

Chairperson for Position Paper and Mathematics Curriculum and Textbook Development

Prof. V.Kannan

Department of Mathematics and Statistics,
HCU, Hyderabad

Chief Advisors

Sri Chukka Ramaiah

Eminent Scholar in Mathematics,
Telangana, Hyderabad.

Dr. H.K.Dewan

Educational Advisor, Vidya Bhavan Society
Udaipur, Rajasthan

QR CODE TEAM

